

ROADWAYS

STREET CLASSIFICATIONS AND RECOMMENDED STANDARD STREET DIMENSIONS	1167.01
TYPICAL SECTIONS AND ASPHALT PAVEMENT COMPOSITION	1167.02
STREET DESIGN STANDARDS	1167.03
TEMPORARY DEAD-END STREETS	1167.04
CONCRETE CURB DETAILS	1167.05
COMMERCIAL AND INDUSTRIAL DRIVE APPROACH	1167.06
RESIDENTIAL DRIVE APPROACH	1167.07
RESIDENTIAL DRIVE APPROACH AND CONCRETE SIDEWALK DETAIL WITH NO CURB LAWN	1167.08
CURB RAMPS	1167.09
CONCRETE SIDEWALK DETAIL	1167.10
ADA RAMP (HERITAGE OVERLAY DISTRICT)	1167.11
RIGHT-OF-WAY WORK AND REPLACEMENT OF SIDEWALK	1167.12
ASPHALT OVERLAY AND MONUMENT	1167.13
MISCELLANEOUS ROADWAY NOTES	1167.14
ALLEY & PARKING LOT DETAIL	1167.15
PUBLIC RIGHT-OF-WAY OPENING AND EXCAVATION	1167.16
STREET IMPROVEMENT CONDITIONS	1167.17
VISION CLEARANCE ON CORNER LOTS	1167.18
TRAFFIC CONTROL DEVICES STATIONARY OPERATIONS IN ONE LANE	1167.19
TYPICAL PAVEMENT RESTORATION DETAILS	1167.20
HANDICAP PARKING STANDARD	1167.21
REPLACEMENT CRITERIA FOR CURB AND GUTTER	1167.22

GENERAL

TRAFFIC CONTROL DEVICES, STREET LIGHTING STANDARDS, AND MISCELLANEOUS GENERAL NOTES	1167.24
LOW STRENGTH MORTAR BACKFILL AND BORING/JACKING	1167.25
CASING PIPE DETAIL	1167.26
SANITATION ENCLOSURE DETAIL	1167.27
CEMETERY HEADSTONE FOUNDATION DETAIL	1167.28
GEOTHERMAL CLOSED-LOOP PIPING SYSTEM (GROUND HEAT EXCHANGER)	1167.29
	1167.30

STORM DRAINAGE

TYPE 1 CATCH BASIN	1167.31
TYPE 2-2-B CATCH BASIN	1167.32
YARD DRAIN	1167.33
TYPE A CATCH BASIN "IN KIND" FOR REPAIR/MAINTENANCE ONLY AS DIRECTED BY CITY	1167.34
TYPE 3 STORM MANHOLE	1167.35
TYPE 3 STORM MANHOLE DETAILS	1167.36
FULL-HEIGHT HEADWALL	1167.37
HALF-HEIGHT HEADWALL	1167.38
STORM SEWER TRENCH DETAILS	1167.39
DETENTION/RETENTION BASIN DETAILS	1167.40
MISCELLANEOUS STORM NOTES	1167.41
EROSION CONTROL NOTES	1167.42
STRAW OR HAY BALES TEMPORARY EROSION CONTROL	1167.43
TEMPORARY EROSION CONTROL	1167.44
REPAIR OF EXISTING FIELD TILE OR STORM PIPE DETAIL	1167.45

WATER DISTRIBUTION

FIRE HYDRANT	1167.51
RESTRAINING JOINTS AND TAPPING SLEEVE FOR WATER MAINS	1167.52
CONCRETE BLOCKING FOR WATER MAINS	1167.53
WATER MAIN TRENCH DETAIL	1167.54
WATER MAIN MATERIAL AND TESTING	1167.55
MISCELLANEOUS WATER NOTES	1167.56
WATER MAIN SERVICE CONNECTION	1167.57
METER PIT INSTALLATION	1167.58
1"-3" COMPOUND METER WITH BYPASS	1167.59
4" COMPOUND METER WITH BYPASS	1167.60
TYPICAL LARGER METER LAYOUT IN BUILDING	1167.61

4" AND LARGER WATER MAIN SERVICE CONNECTION (DOMESTIC)	1167.62
LIMITED AREA SPRINKLER SYSTEM DETAIL	1167.63
REDUCED PRESSURE DETECTOR ASSEMBLY	1167.64
DOUBLE DETECTOR CHECK VALVE ASSEMBLY DETAIL	1167.65
STANDARD INSTALLATION FOR IRRIGATION METERS AND BACKFLOW PREVENTER	1167.66
IRRIGATION DETAILS	1167.67
2" FIRE LINE AND 4" AND LARGER FIRE LINE	1167.68
FIRE LINE DETAIL AND NOTES	1167.69
FIRE LINE DETAIL AND NOTES	1167.70
INSIDE DEDUCT METER	1167.71

SANITARY SEWERS

TYPE 3 SANITARY MANHOLE	1167.81
TYPE D SANITARY DROP MANHOLE	1167.82
OUTSIDE SANITARY DROP ON EXISTING MANHOLE TYPE 1	1167.83
INSIDE SANITARY DROP ON EXISTING MANHOLE TYPE 2	1167.84
MISCELLANEOUS SANITARY MANHOLE DETAILS	1167.84
SANITARY SEWER TRENCH DETAIL	1167.85
REPAIR OF EXISTING SANITARY SEWER PIPE DETAIL	1167.86
SERVICE RISER AND SERVICE LATERAL NEW CONSTRUCTION ONLY	1167.87
SANITARY SEWER SADDLE DETAILS	1167.88
SANITARY SEWER CLEANOUT DETAIL	1167.89
BUILDING CONNECTION DETAIL	1167.90
SANITARY SEWER TESTING NOTES	1167.91
MISCELLANEOUS SANITARY SEWER NOTES	1167.92
SERVICE CONNECTION LOCATION REFERENCE	1167.93
SERVICE CONNECTION LOCATION REFERENCE (BUILDING IN PLACE)	1167.94
SEWAGE COMBINATION AIR VALVE CHAMBER	1167.95

STREET FUNCTIONAL CLASSIFICATIONS

THE CITY ENGINEER WILL PROVIDE THE CLASSIFICATION OF ALL STREETS PRIOR TO DESIGN AND CONSTRUCTION. THE CLASSIFICATIONS ARE AS FOLLOWS:

A. THOROUGHFARE-MAIN

THE THOROUGHFARE-MAIN SYSTEM SHOULD SERVE THE MAJOR AREAS, THE HIGHEST TRAFFIC VOLUME CORRIDORS, AND THE LONGEST TRIPS. THE SYSTEM SHOULD CARRY A HIGH PROPORTION OF THE TOTAL URBAN AREA TRAVEL ON A MINIMUM OF MILEAGE. TYPICALLY HAVING TRAFFIC VOLUMES GREATER THAN 10,000 ADT.

B. THOROUGHFARE-SECONDARY

THE THOROUGHFARE-SECONDARY SYSTEM CONTAINS FACILITIES THAT PLACE MORE EMPHASIS ON LAND ACCESS THAN THE THOROUGHFARE-MAIN SYSTEM AND OFFERS A LOWER LEVEL OF TRAFFIC MOBILITY. SUCH FACILITIES PROVIDE INTRA-COMMUNITY CONTINUITY, BUT IDEALLY SHOULD NOT PENETRATE IDENTIFIABLE NEIGHBORHOODS. TYPICALLY HAVING TRAFFIC VOLUMES BETWEEN 5,000 AND 10,000 ADT.

C. INDUSTRIAL/COMMERCIAL

A STREET DESIGNED TO CONDUCT TRAFFIC FOR INDUSTRIAL AND COMMERCIAL USES, UNLESS LARGE VOLUMES OF TRAFFIC ARE ANTICIPATED.

D. COLLECTOR STREET/RESIDENTIAL

THE COLLECTOR STREET SYSTEM PENETRATES NEIGHBORHOODS DISTRIBUTING TRIPS FROM THE THOROUGHFARE THROUGH THE AREA TO THE ULTIMATE DESTINATION WHICH MAY BE ON A LOCAL OR COLLECTOR STREET. CONVERSELY, THE COLLECTOR STREET ALSO COLLECTS TRAFFIC FROM LOCAL STREETS IN THE NEIGHBORHOOD AND CHANNELS IT INTO THE ARTERIAL SYSTEM OR ANOTHER COLLECTOR STREET.

E. RESIDENTIAL THROUGH STREET

A RESIDENTIAL THROUGH STREET REFERS TO STREETS THAT CONNECT COLLECTOR STREETS AND/OR OTHER MAJOR STREETS OR HIGHWAYS TO OTHER COLLECTOR STREETS. THEY PRIMARILY CARRY TRAFFIC FROM COLLECTORS TO LOCAL RESIDENTIAL STREETS.

F. LOCAL RESIDENTIAL STREET

A LOCAL RESIDENTIAL STREET CONTAINS STREETS THAT PROVIDE ACCESS TO HOMES BUT NOT TO THROUGH TRAFFIC. THE ONLY TRAFFIC ON LOCAL RESIDENTIAL STREETS ARE HOMEOWNERS GOING TO THEIR HOMES FROM RESIDENTIAL THROUGH STREETS.

DESIRED MINIMUM STANDARDS		
STREET FUNCTIONAL CLASSIFICATION	RIGHT-OF-WAY WIDTH	BACK-TO-BACK CURB
	(FT.)	(FT.)
THOROUGHFARE-MAIN	100*	64*
THOROUGHFARE-SECONDARY	80*	52*
INDUSTRIAL,/COMMERCIAL/RES. COLLECTOR	61	41
RESIDENTIAL THROUGH STREET	60	37
LOCAL STREET	50	33

* SEE DESIGN CRITERIA

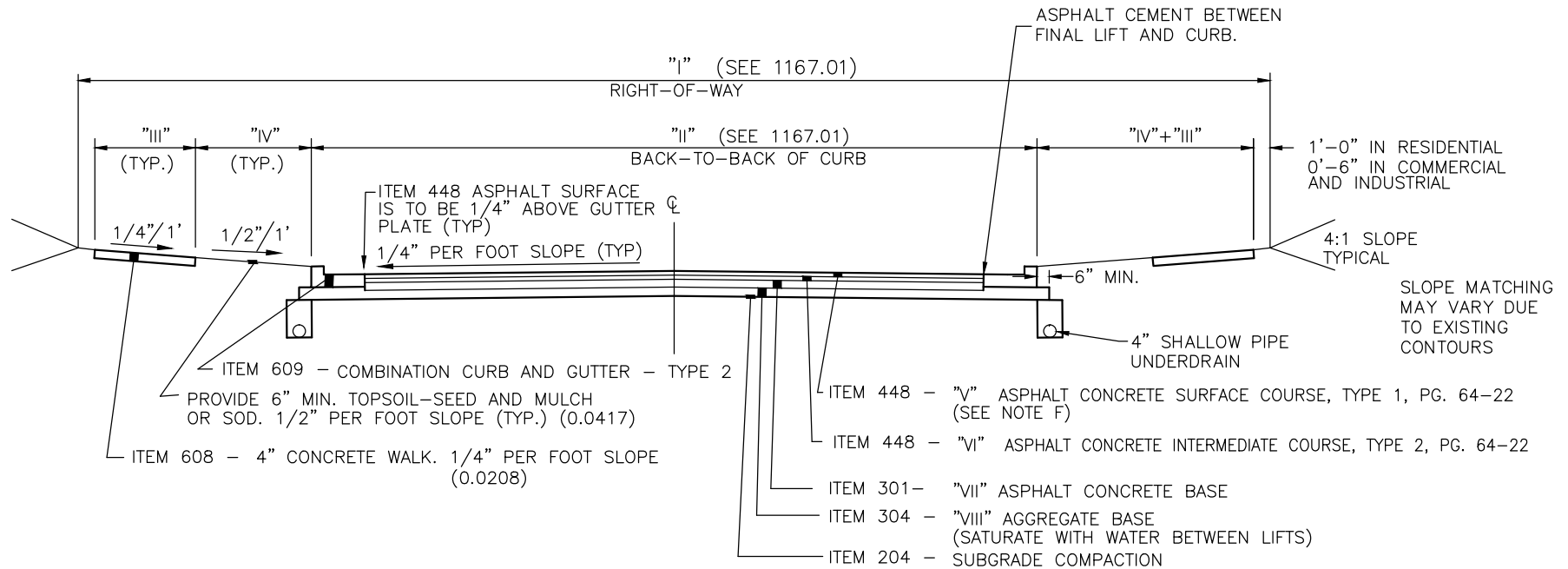

NOTES

- A.** ALL WORK TO CONFORM TO ODOT CONSTRUCTION AND MATERIAL SPECIFICATIONS LATEST REVISION UNLESS OTHERWISE SPECIFIED.
- B.** ITEM 407 TACK COAT, SHALL BE REQUIRED WHEN 10 DAYS HAVE ELAPSED BETWEEN BITUMINOUS PAVEMENT LIFTS UNLESS OTHERWISE SPECIFIED BY THE ENGINEER. APPLICATION RATE IS 0.08 GALLON PER SQUARE YARD.
- C.** ALL BUTT JOINTS SHALL BE SEALED WITH PG 64-22 WITHIN 24 HOURS AFTER PLACEMENT OF ITEM 448.
- D.** STANDARD DIMENSIONS FOR (II) B\B CURB AND (IV) CURB LAWN WIDTH ASSUME PARKING ON BOTH SIDES.
- E.** SIDEWALK OF 4' WIDTH MAY BE APPROVED BY THE CITY ON ARTERIAL, INDUSTRIAL AND COMMERCIAL.
- F.** IN AREAS WITH HIGH POTENTIAL OF PUSHING, SHOVING OR HEAVING, USE ITEM 448 ASPHALT CONCRETE SURFACE COURSE TYPE 1H, PG. 70-22. IN SMALL QUANTITY AREAS USE TYPE 1, PG 64-22 WITH GILSONITE ADDITIVE.
- G.** ALL NEW STREETS ARE TO BE CONSTRUCTED USING ASPHALT. CONCRETE PAVEMENT WILL NOT BE ACCEPTED.
- H.** ITEM 408 PRIME COAT SHALL BE APPLIED ON ITEM 304 AGGREGATE BASE AT THE RATE OF 0.4 GAL/SY PRIOR TO ASPHALT.

MINIMUM STANDARDS						
	ITEM	DESCRIPTION	THOROUGHFARE	COMM., IND. & RES. COLLECTOR	RESIDENTIAL THROUGH STREET	LOCAL
STANDARD DIMENSIONS	I	RIGHT-OF-WAY	*	61'	60'	50'
	II	B\B CURB	*	41'	37'	33'
	III	SIDEWALK WIDTH	*	5'	4'	4'
	IV	CURB LAWN WIDTH	*	4'	7'	4'
AGGREGATE BASE	V	ITEM 448	1-1/2" MIN	1-1/2" MIN	1-1/2" MIN	1-1/2" MIN
	VI	ITEM 448	1-1/2"	1-1/2"	1-1/2"	1-1/2"
	VII	ITEM 301	6"	5"	4"	3"
	VIII	ITEM 304	9" 2 LIFTS	9" 2 LIFTS	9" 2 LIFTS	9" 2 LIFTS
ASPHALT BASE	V	ITEM 448	1-1/2" MIN	1-1/2" MIN	1-1/2" MIN	1-1/2" MIN
	VI	ITEM 448	1-1/2"	1-1/2"	1-1/2"	1-1/2"
	VII	ITEM 301	8" 2 LIFTS	7" 2 LIFTS	6"	5"
	VIII	ITEM 304	4"	4"	4"	4"

* SEE DESIGN CRITERIA AND CITY ENGINEER
 A 10' EASEMENT IS TO BE PLACED ALONG THE RIGHT-OF-WAY LINE.

TYPICAL STREET AND CUL-DE-SAC PLAN

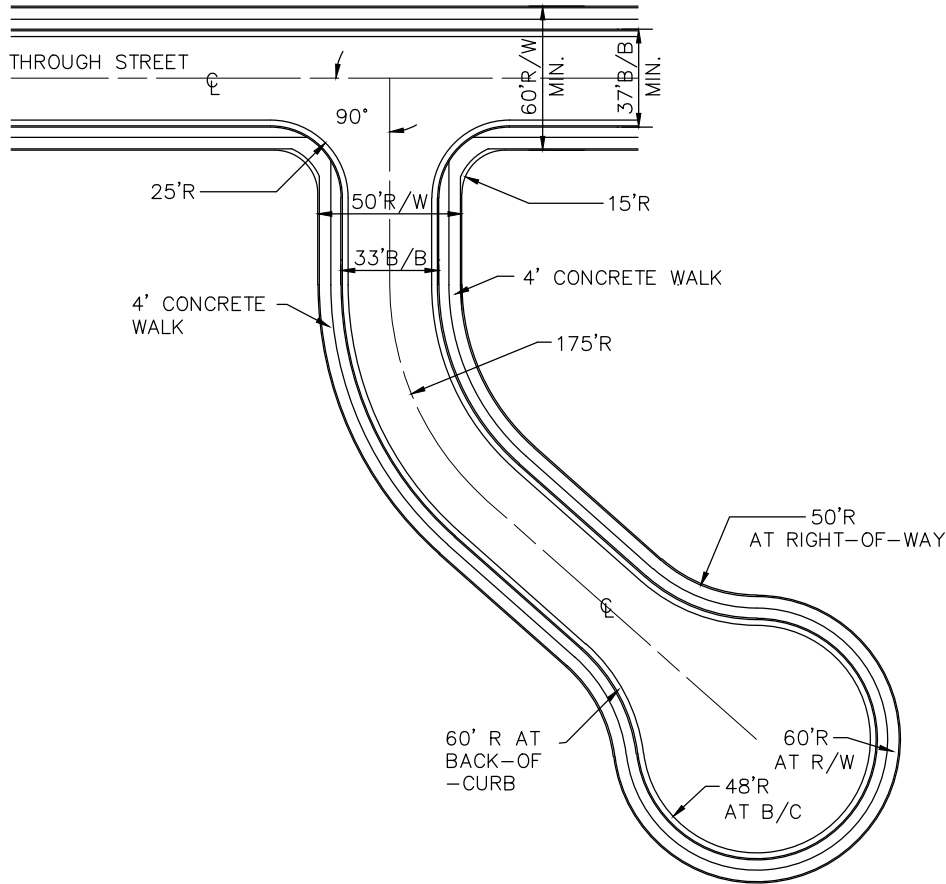

STREET DESIGN STANDARDS

	* 25 mph LOCAL, THRU STREETS	* 35 mph COLLECTOR
MINIMUM CENTERLINE GRADES	.50%	.50%
MAXIMUM CENTERLINE GRADES	10%	7%
MINIMUM LENGTH OF VERTICAL CURVE (SEE NOTE C).	25FT.	50FT.
MINIMUM CENTERLINE RADIUS	250FT.	400FT.
MINIMUM LENGTH TANGENT BETWEEN CURVES	50FT.	50FT.
MINIMUM BACK-OF-CURB RADIUS	25FT.	25FT.
MINIMUM HORIZONTAL VISIBILITY	150FT.	250FT.
MINIMUM STOPPING SIGHT DISTANCE (MEASURED FROM 3.5' EYE-LEVEL TO 6" OBJECT HEIGHT)	150FT.	250FT.
MAXIMUM CENTERLINE GRADE WITHIN 100' OF AN INTERSECTION	3%	3%
MINIMUM RIGHT-OF-WAY WIDTH	50FT., 60FT.	61FT.
MINIMUM PAVEMENT WIDTH BACK-TO-BACK OF CURB	33FT., 37 FT.	41FT.

NOTES

- A.** THESE ARE MINIMUM DESIGN STANDARDS AND MAY BE REQUIRED TO BE INCREASED TO COMPLY WITH THE CITY'S OFFICIAL THOROUGHFARE PLAN.
- B.** THE MAXIMUM LENGTH FOR CUL-DE-SAC STREET SHALL BE 600' (THE MINIMUM SHALL BE 160') CENTER-OF-STREET TO CENTER OF CUL-DE-SAC UNLESS AUTHORIZED BY CITY PLANNING COMMISSION.
- C.** MINIMUM LENGTH OF VERTICAL CURVE CAN BE REDUCED OR ELIMINATED TO ALLOW FOR PROPER DRAINAGE, WITH APPROVAL OF THE CITY.

*THESE ARE DESIGN SPEEDS, NOT NECESSARILY POSTED SPEEDS.

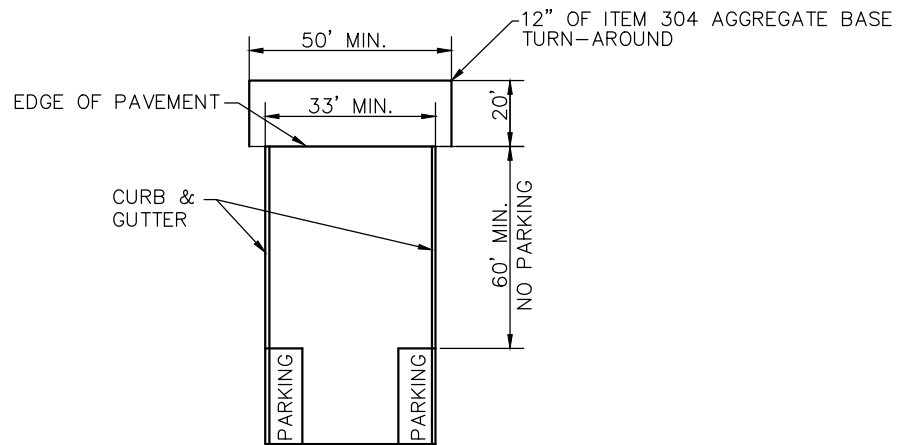

TEMPORARY DEAD-END STREETS

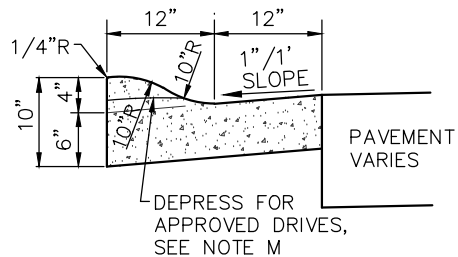

**TYPE 1
COMBINATION ROLL CURB AND GUTTER**

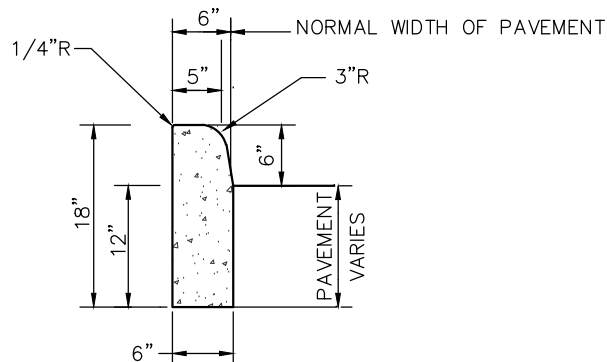

**TYPE 6
BARRIER CURB**

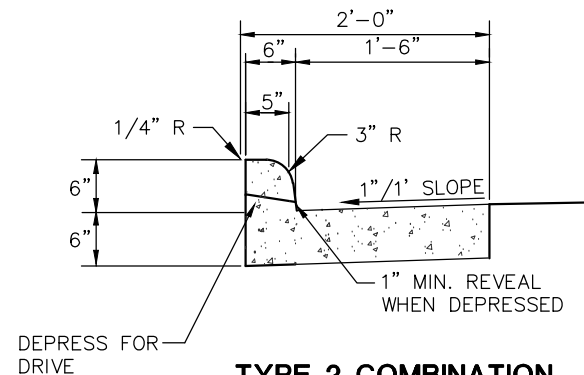

**TYPE 2 COMBINATION
CURB AND GUTTER**

NOTES

- A.** CONCRETE WORK SHALL MEET THE REQUIREMENTS SET FORTH IN ODOT ITEM 609 CURBING.
- B.** CURBING SHALL HAVE CONTRACTION JOINTS EVERY 10' AND EXPANSION JOINTS WITH 1/2" EXPANSION MATERIAL EVERY 60'. 1" EXPANSION MATERIAL TO BE USED 2' TO 3' BEYOND BOTH SIDES OF CATCH BASINS WITH TWO DOWELS CENTERED IN THE GUTTER SPANNING THE 1" EXPANSION.
- C.** MINIMUM OF 6" OF ODOT 304 SHALL BE PLACED UNDER CURBING WHEN BEING NEWLY CONSTRUCTED.
- D.** CURBING SHALL BE BACKFILLED IMMEDIATELY AFTER FORMS ARE REMOVED OR AS SOON AS PRACTICAL WHEN SLIP FORMING PRIOR TO OTHER CONSTRUCTION OPERATIONS.
- E.** PROVIDE BROOM FINISH AND EDGING TO ALL EXPOSED SURFACES.
- F.** APPLY WHITE CURING COMPOUND ON ALL SURFACES INCLUDING BACK IMMEDIATELY AFTER FINISHING SURFACES. ANY OTHER METHOD OR TYPE OF CURING COMPOUND MUST BE PREAPPROVED.
- G.** CONCRETE SHALL BE ODOT CLASS QC-1 WITH FIBERMESH (4000 PSI AT 28 DAYS, 1 LBS/CY FIBERMESH)
- H.** CONCRETE SHALL CONTAIN 6% ± 1% OF TOTAL AIR.
- I.** TYPE 6 CURBS ARE FOR USE AROUND MEDIAN SECTIONS ONLY.
- J.** UNDERDRAIN MUST BE INSTALLED PRIOR TO CURB INSTALLATION.
- K.** MINIMUM FLOW LINE SLOPE OF PERFORATED PIPE IS 0.003 FT/FT TO OUTLET.
- L.** UNDERDRAIN MAY BE USED FOR SUMP PUMP DRAINS WITH A MANUFACTURED TEE, WHEN NO OTHER STORM OUTLET IS AVAILABLE AS DETERMINED BY THE CITY. IN NO CASE SHALL DOWNSPOUTS BE TIED INTO THE UNDERDRAIN.
- M.** ROLL CURB AND GUTTER MAY BE DEPRESSED AS SHOWN ABOVE FOR DRIVES THAT HAVE A MINIMUM GRADE OF +1% FOR A MINIMUM OF 30' BACK OF THE CURB AND GUTTER.
- N.** WHERE ASPHALTIC CONCRETE PAVEMENT IS DISTURBED, THE PAVEMENT SHALL BE REPLACED WITH HOT MIX ASPHALT SURFACE COURSE THE FULL DEPTH OF THE DISTURBANCE UNLESS AN EXCEPTION IS GRANTED BY THE CITY DURING THE PERMIT PROCESS.

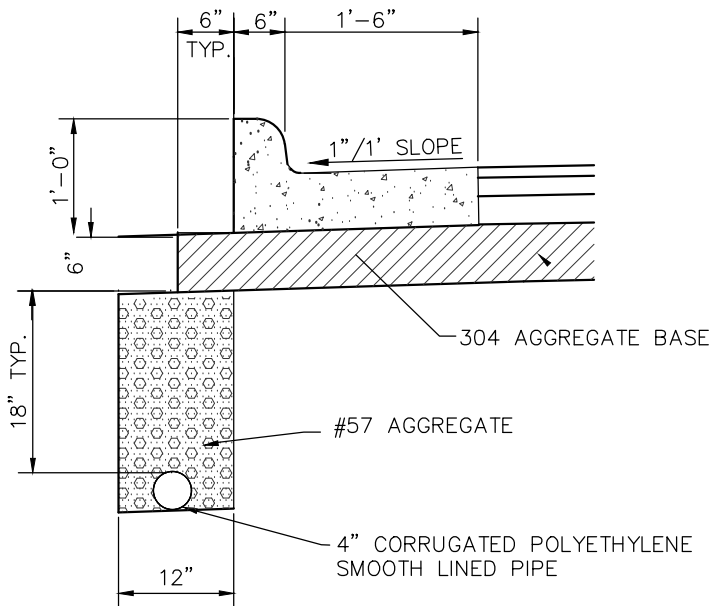

4" SHALLOW PIPE UNDERDRAIN DETAIL
(ONLY AS REQUIRED BY THE CITY)

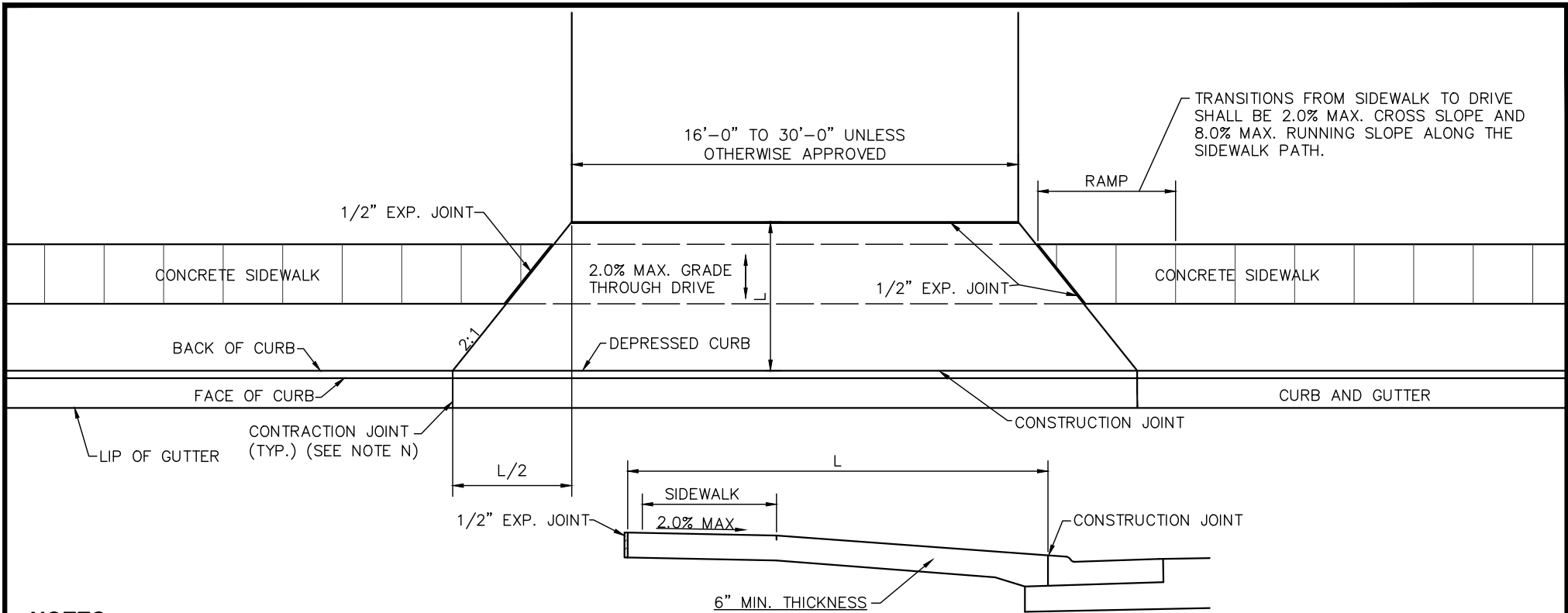

NOTES

A. DRIVE APPROACHES SHALL MEET THE REQUIREMENTS OF ODOT ITEM 452 AND 499 CAST IN PLACE CONCRETE.

B. DRIVE APPROACHES SHALL NOT BE POURED MONOLITHICALLY WITH CURB.

C. MAXIMUM JOINT SPACING SHALL BE 10' LONGITUDINALLY AND TRANSVERSELY WITH JOINTS AT TAPERS.

D. EXPANSION MATERIAL SHALL BE 1/2" PREMOLDED.

E. COMPACTED AGGREGATE SHALL BE PLACED UNDER DRIVE APPROACHES IF DETERMINED NECESSARY BY THE CITY.

F. PROVIDE BROOM FINISH AND EDGING TO ALL EXPOSED SURFACES.

G. WHERE CURB HAS NOT BEEN PROPERLY DROPPED AT DRIVE APPROACHES, THE CURB AND GUTTER SHALL BE ENTIRELY REMOVED AND REPLACED BY THE CONTRACTOR/OWNER UNLESS OTHERWISE APPROVED.

H. WHERE ASPHALTIC CONCRETE PAVEMENT IS DISTURBED, THE PAVEMENT SHALL BE REPLACED WITH HOT MIX ASPHALT SURFACE COURSE THE FULL DEPTH OF THE DISTURBANCE UNLESS AN EXCEPTION IS GRANTED BY THE CITY DURING THE PERMIT PROCESS.

I. JOINTS SHALL BE CLEANED AND EDGED BY A 1/4" RADIUS EDGER. LONGITUDINAL JOINTS SHALL BE AS DIRECTED BY THE CITY. EXPANSION JOINTS SHALL BE OF SUCH DIMENSIONS AS SHOWN ON STANDARD DRAWINGS FOR CONSTRUCTION JOINTS.

J. EXPANSION JOINT LOCATION MAY BE ALTERED WITH CITY APPROVAL.

K. MINIMUM WIDTH FOR ONE-WAY TRAFFIC IS 16'-0". MINIMUM WIDTH FOR TWO-WAY TRAFFIC IS 25'-0". MAXIMUM WIDTH IS 30'-0" UNLESS OTHERWISE APPROVED BY THE CITY.

L. CONCRETE SHALL BE ODOT CLASS QC-1. (4000 PSI AT 28 DAYS)

M. CONCRETE SHALL CONTAIN 6% ± 1% OF TOTAL AIR.

N. IF CURB AND GUTTER ARE REMOVED AND REPLACED DURING DRIVEWAY CONSTRUCTION, JOINTS BETWEEN EXISTING AND NEW CURB AND GUTTER ARE TO CONTAIN 1/2" EXPANSION MATERIAL.

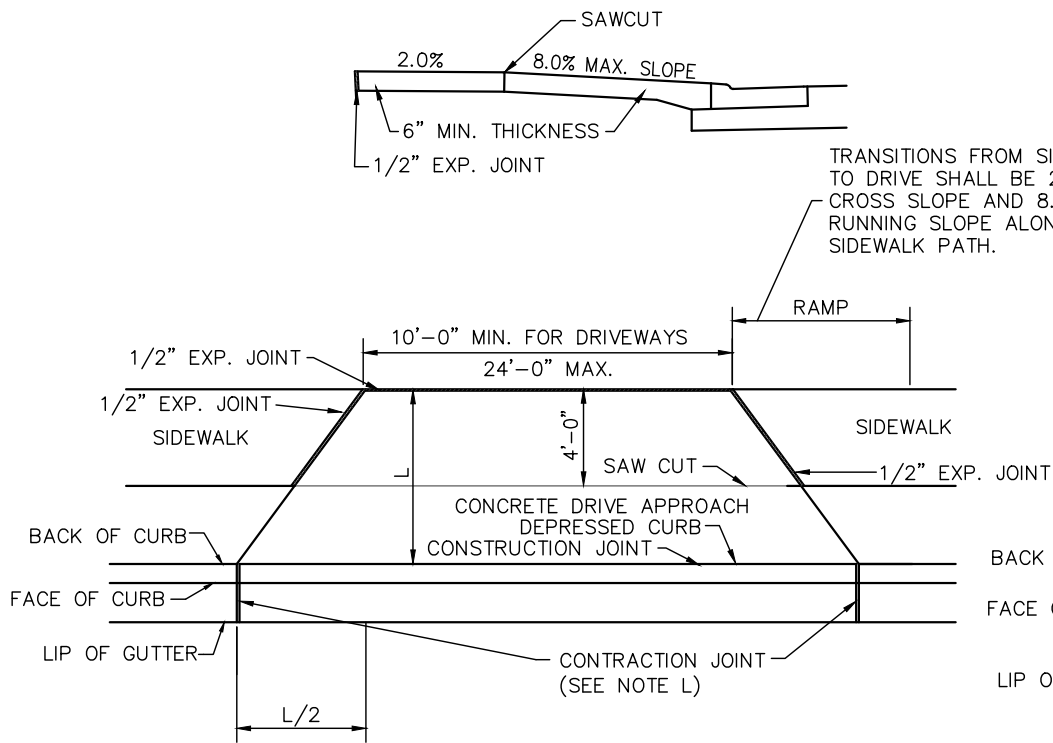

**FOR TREE LAWNS OF
LESS THAN 6'-0"**

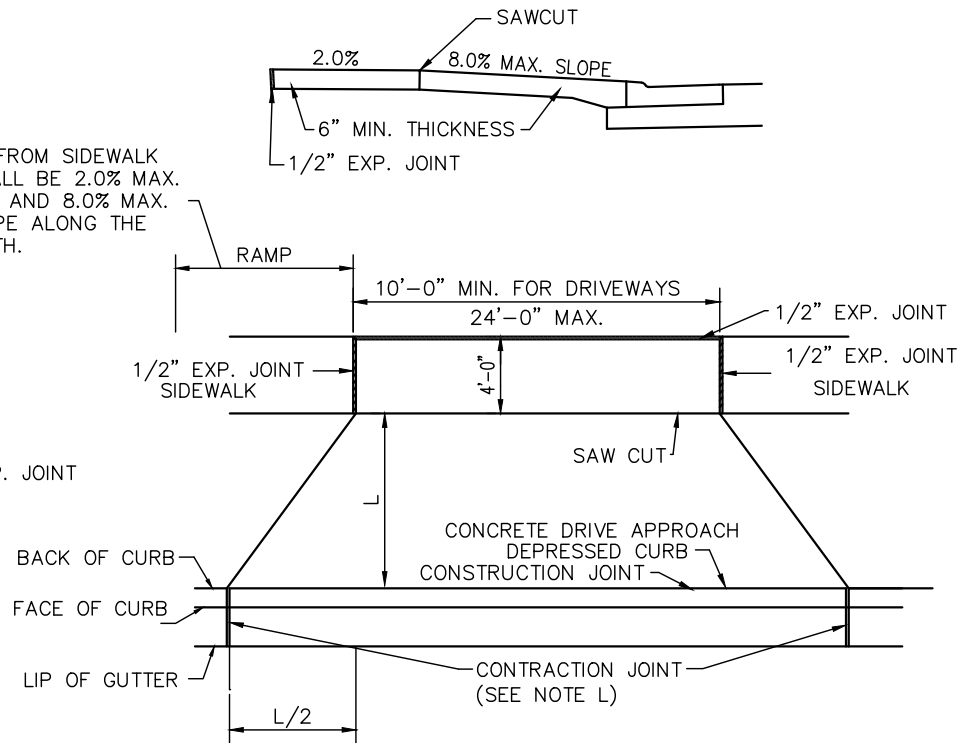

**FOR TREE LAWNS OF
6'-0" OR MORE**

NOTES

- A.** DRIVE APPROACHES SHALL MEET THE REQUIREMENTS OF ODOT ITEM 452 AND 499 CAST-IN-PLACE CONCRETE.
- B.** MAXIMUM JOINT SPACING SHALL BE 10' LONGITUDINALLY, TRANSVERSELY AND AT TAPERS.
- C.** EXPANSION MATERIAL SHALL BE 1/2" PREMOLDED.
- D.** 3" OF GRAVEL SHALL BE PLACED UNDER DRIVE APPROACHES IF DETERMINED NECESSARY BY THE CITY.
- E.** PROVIDE BROOM FINISH AND EDGING TO ALL EXPOSED SURFACES.

- F.** WHERE CURB HAS NOT BEEN PROPERLY DROPPED AT DRIVE APPROACHES, THE CURB AND GUTTER SHALL BE ENTIRELY REMOVED AND REPLACED BY THE CONTRACTOR/OWNER UNLESS OTHERWISE APPROVED.
- G.** JOINTS SHALL BE CLEANED AND EDGED BY A 1/4" RADIUS EDGER. LONGITUDINAL JOINTS SHALL BE AS DIRECTED BY THE CITY. EXPANSION JOINTS SHALL BE OF SUCH DIMENSIONS AS SHOWN ON STANDARD DRAWINGS FOR CONSTRUCTION JOINTS.
- H.** WHERE ASPHALTIC CONCRETE PAVEMENT IS DISTURBED, THE PAVEMENT SHALL BE REPLACED WITH HOT MIX ASPHALT SURFACE COURSE THE FULL DEPTH OF THE DISTURBANCE UNLESS AN EXCEPTION IS GRANTED BY THE CITY DURING THE PERMIT PROCESS.
- I.** EXPANSION JOINT LOCATIONS MAY BE ALTERED WITH CITY APPROVAL.

- J.** CONCRETE SHALL BE ODOT CLASS QC-1 (4000 PSI AT 28 DAYS)
- K.** CONCRETE SHALL CONTAIN 6% ± 1% OF TOTAL AIR.
- L.** IF CURB AND GUTTER ARE REMOVED AND REPLACED DURING DRIVEWAY CONSTRUCTION, JOINTS BETWEEN EXISTING AND NEW CURB AND GUTTER ARE TO CONTAIN 1/2" EXPANSION MATERIAL.
- M.** FOR PROPERTIES LOCATED IN THE CORRIDOR OVERLAY DISTRICT, PLEASE REFER TO THE CITY OF URBANA'S CORRIDOR DEVELOPMENT STANDARDS.

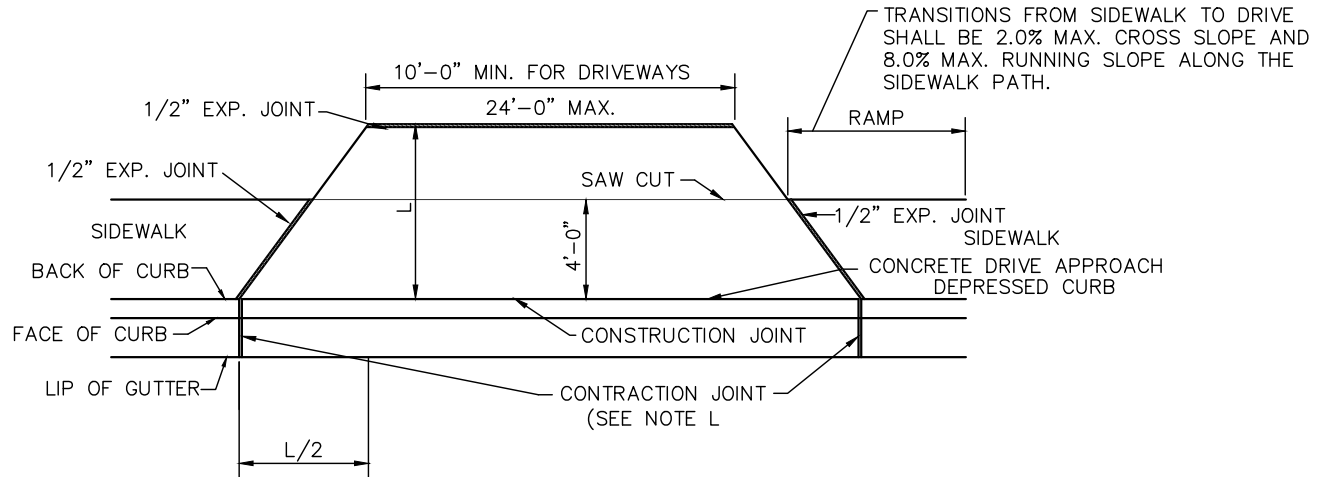
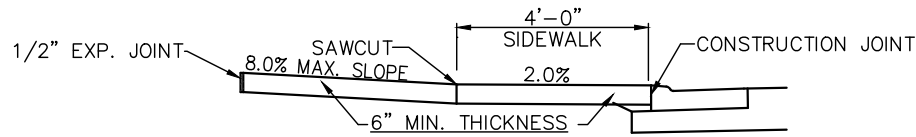

**DRIVE APRON WITH
NO CURB LAWN**

FOR DRIVEWAY NOTES SEE PAGE 1167.07

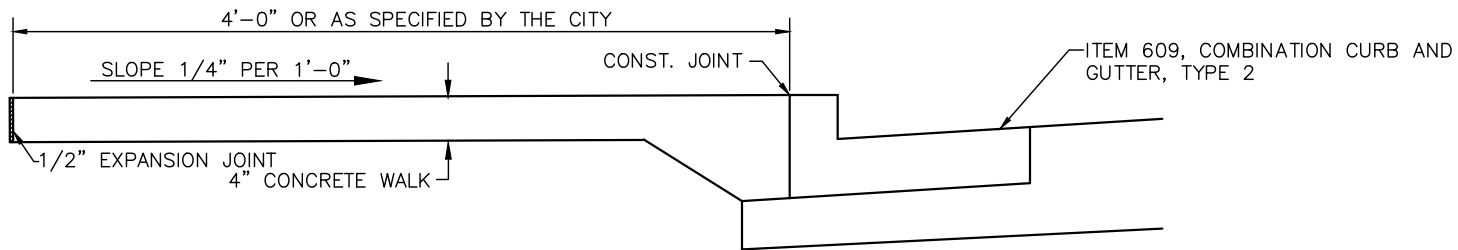

CONCRETE SIDEWALK ABUTTING TYPE 2 CURB DETAIL

NOTES

- A.** CITY TO SPECIFY ODOT TYPE A1, A2, B1, B2, B3, C1 OR C2 CURB RAMP BASED ON ODOT STANDARD CONSTRUCTION DRAWING BP 7.1, LATEST REVISION..
- B.** ANY COMBINATION OF SIDE SLOPES ON OPPOSITE SIDES OF A RAMP MAY BE USED TO BEST FIT THE SITE CONDITIONS.
- C.** THE MINIMUM RAMP LENGTH IS 6' FROM BACK OF A 6" CURB AND MAY BE INCREASED WHERE FEASIBLE TO OBTAIN A FLATTER RAMP SLOPE OR TO BETTER BLEND WITH THE WALK CONFIGURATION.
- D.** WALK THICKNESS IN THE RAMP SLOPES SHALL BE 4" MINIMUM OR THICKER AS NECESSARY TO MATCH ADJACENT WALK THICKNESS.
- E.** CURB RAMPS SHALL MEET AND BE FINISHED TO AMERICANS WITH DISABILITIES ACT (A.D.A.) STANDARDS.
- F.** TEXTURE OF CONCRETE SURFACE SHALL BE OBTAINED BY COURSE BROOMING TRAVERSE TO THE RAMP SLOPES AND SHALL BE ROUGHER THAN ADJACENT WALK.
- G.** CURB RAMPS SHALL MEET THE REQUIREMENTS OF ODOT ITEM 608 UNLESS OTHERWISE SPECIFIED WITHIN.
- H.** CONCRETE SHALL BE ODOT CLASS QC-1 (4000 PSI AT 28 DAYS).
- I.** CONCRETE SHALL CONTAIN 6% ± 1% OF TOTAL AIR.

- J.** FOR RECONSTRUCTION JOBS, THE CURB RAMPS WILL HAVE TO BE ADDRESSED BASED ON THE EXISTING CONDITIONS.
- K.** TRUNCATED DOME SPECIFICATIONS:
INSTALL DETECTABLE WARNINGS (TRUNCATED DOMES) FOR A DISTANCE OF 24" FROM THE BACK OF CURB FOR THE ENTIRE WIDTH OF THE RAMP OPENING WHERE IT IS FLUSH WITH THE PAVEMENT.
-DOMES SHALL MEET A.D.A. REQUIREMENTS FOR DETECTABLE WARNINGS
-CAST-IN PLACE (NON-REPLACEABLE), ENGINEERED PLASTIC/POLYMER COMPOSITE DETECTABLE WARNING DEVICES SHALL BE USED AND LAID ON TOP OF A 4" UNREINFORCED CONCRETE BASE. SETTING THE PLASTIC/POLYMER PANELS SHALL BE IN ACCORDANCE WITH MANUFACTURER'S INSTRUCTIONS.

-JOINTS ARE TO BE FLUSH WITH TOP SURFACE AND STRUCK SO AS TO GIVE A SMOOTH TRANSITION FROM DOME TO CONCRETE SURFACE. PANEL SHOULD NOT DIFFER FROM THE SURROUNDING CONCRETE BY MORE THAN 1/8" IN HEIGHT. TRUNCATED DOMES THAT DO NOT CONFORM TO THE SMOOTHNESS REQUIREMENT SHALL BE REMOVED AND REPLACED AT THE EXPENSE OF THE CONTRACTOR AS DETERMINED BY THE CITY. FACE OF ALL TRUNCATED DOMES SHALL BE CLEAN OF CEMENT.
-ACCEPTABLE MANUFACTURES AND PRODUCTS ARE AVAILABLE ON OHIO DEPARTMENT OF TRANSPORTATION'S APPROVED DETECTABLE WARNING PRODUCT LIST. AN APPROVED EQUAL WILL BE CONSIDERED FOR CITY PROJECTS. PANELS SHALL BE BRICK RED IN COLOR. NO CAST IRON TRUNCATED DOMES WILL BE ACCEPTED.

**CITY OF
URBANA**

CURB RAMPS

REVISIONS:
04-27-11
12-20-12
04-10-19

DATE
APPROVED:
01-13-06

PAGE No.
1167.09

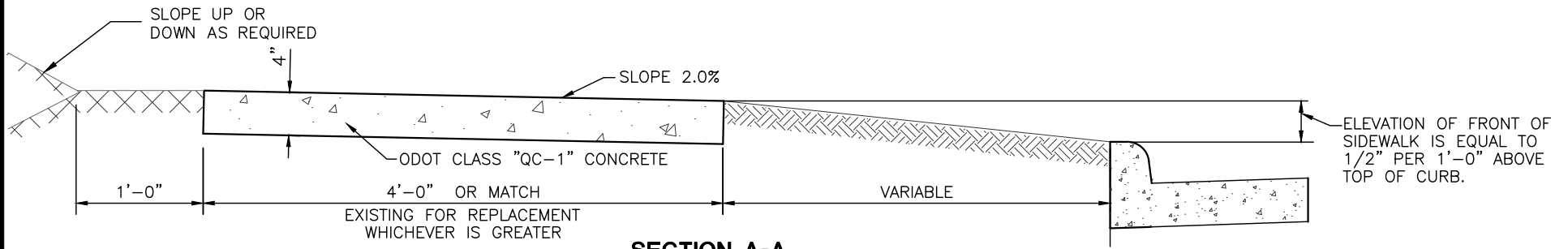

SECTION A-A

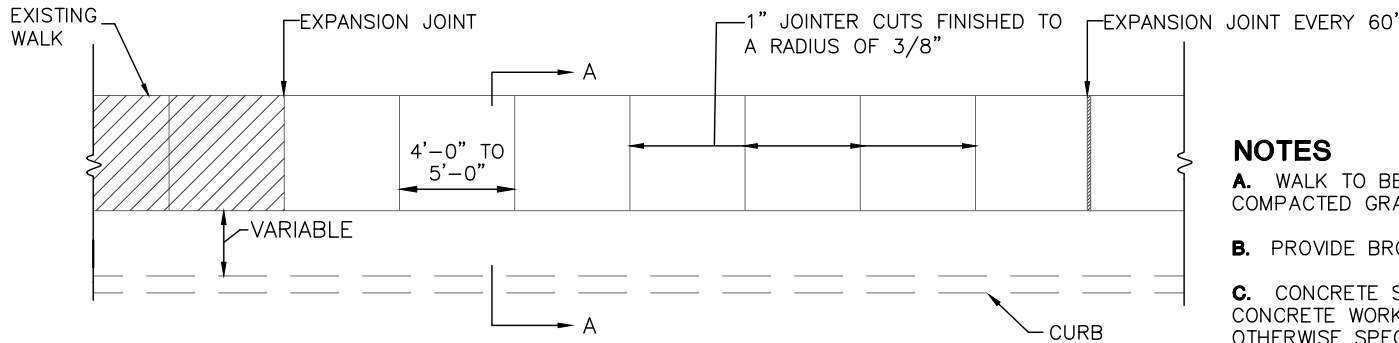

PLAN VIEW

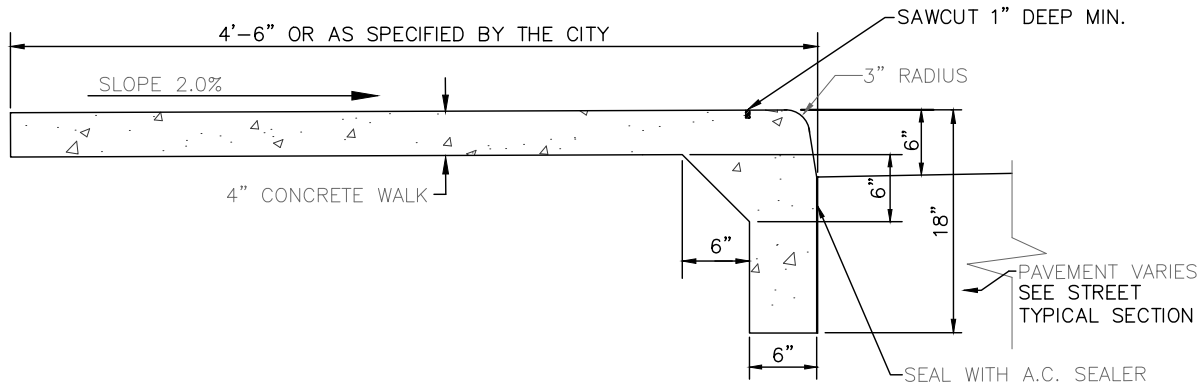

COMBINED CURB AND SIDEWALK DETAIL

NOTES

- A.** WALK TO BE POURED ON UNDISTURBED EARTH OR COMPACTED GRANULAR BEDDING.
- B.** PROVIDE BROOM FINISH TO ALL EXPOSED SURFACES.
- C.** CONCRETE SHALL CONFORM TO ODOT ITEM 499 CONCRETE. CONCRETE WORK SHALL CONFORM TO ODOT ITEM 608, UNLESS OTHERWISE SPECIFIED WITHIN.
- D.** PROVIDE EDGING AROUND ALL EXPOSED SURFACES. RETRACE LONGITUDINAL EDGES AFTER BROOMING. DO NOT RETRACE TRANSVERSE JOINTS.
- E.** USE WHITE CURING COMPOUND IMMEDIATELY AFTER FINISHING SURFACES. ANY OTHER METHOD OR TYPE OF CURING COMPOUND MUST BE PREAPPROVED.
- F.** WHEN RENOVATING EXISTING STREETS, THE SIDEWALKS SHALL BE REPLACED TO CONFORM WITH THE CITY CONSTRUCTION STANDARDS AND DRAWINGS.
- G.** CONCRETE SHALL BE ODOT CLASS QC-1 (4000 PSI AT 28 DAYS).
- H.** CONCRETE SHALL CONTAIN 6% ± 1% OF TOTAL AIR.
- I.** SIDEWALKS PARALLEL AND ADJACENT TO THE STREET SHALL NOT HAVE A FAUX FINISH (i.e. STAMPING OR DYEING).
- J.** FOR SIDEWALK LOCATED IN THE CORRIDOR DEVELOPMENT AREA, PLEASE REFER TO STANDARDS SET FORTH IN THE CITY OF URBANA CORRIDOR DEVELOPMENT STANDARDS.

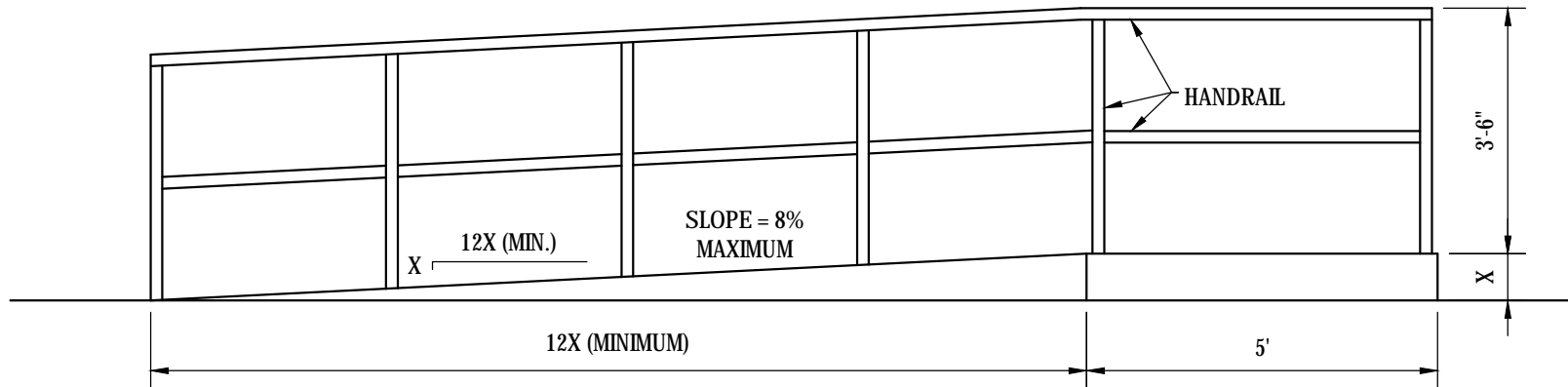

ELEVATION A-A

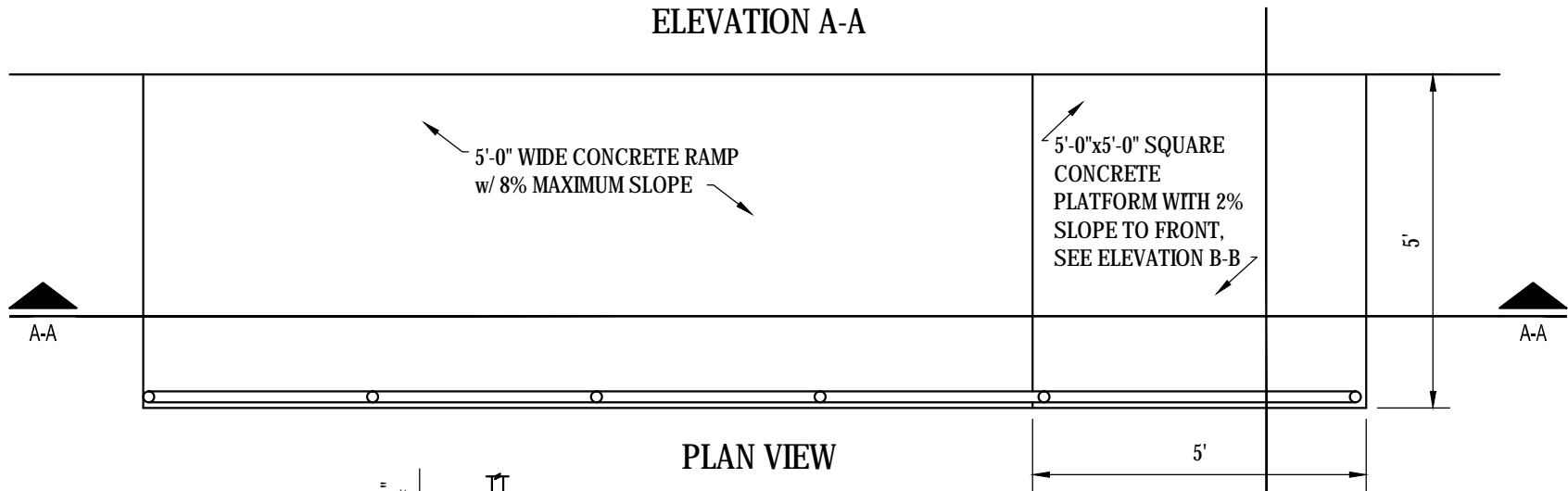

PLAN VIEW

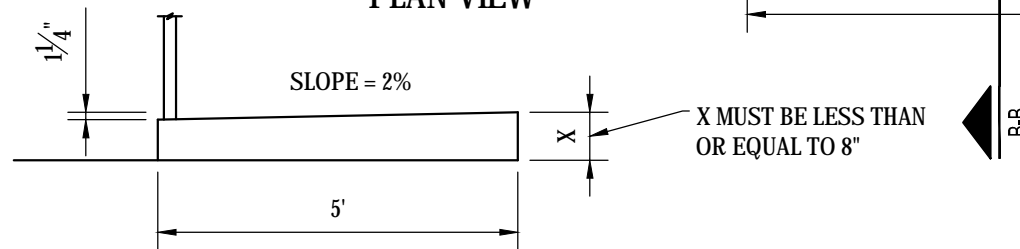

ELEVATION B-B

NOTES:

1. CONCRETE TO BE UNPAINTED
2. HANDRAIL TO BE METAL BLACK IN COLOR

EXAMPLE: 3/4 INCH TRIP HAZARD



ADJOINING BLOCKS OR PORTIONS THEREOF WHOSE EDGES DIFFER VERTICALLY BY MORE THAN 3/4 INCH.



EXAMPLE: DETERIORATION



ANY SIDEWALK THAT IS DETERIORATED OR SHOWS SURFACE SPALLING, LEAVING IT VERY ROUGH, UNSAFE, OR WITH AGGREGATE PROTRUDING.

EXAMPLE: ABRUPT SLOPE



BLOCKS, OR PORTION OF BLOCKS, THAT CAUSE AN ABRUPT CHANGE OF 1 INCH PER FOOT (OR MORE) IN ANY DIRECTION OF THE SIDEWALK.



EXAMPLE: PLATES, COVERS, ETC.



METAL OR OTHER PLATES, COVERS, OR GRATINGS THAT ARE NOT FLUSH (3/4 INCH OR MORE VERTICAL DIFFERENCE) WITH THE ADJOINING SIDEWALK SURFACE, ARE STRUCTURALLY UNSAFE, OR CAUSE A NUISANCE DUE TO SLIPPERY SURFACES ETC.

EXAMPLE: CRACKS



ANY SIDEWALK BLOCK (BASED ON 20 SQ. FT.) HAVING A CRACK OR CRACKS IN IT OF AT LEAST 1/2 INCH WIDE WITH A MINIMUM OF 4 LINEAL FEET IN ONE BLOCK. (VARIOUS SIZE BLOCKS WILL BE EVALUATED PROPORTIONALLY.)



PERMITS, INSPECTION, AND WORK RULES

- A.** NO PERSON SHALL TEAR UP OR DIG INTO ANY PUBLIC RIGHT-OF-WAY OR STREET FOR THE PURPOSE OF CONSTRUCTING OR REPAIRING THE SIDEWALK, CURBING, OR GUTTERS THEREON OR FOR ANY OTHER PURPOSE, WITHOUT HAVING FIRST OBTAINED A PERMIT FROM THE ENGINEERING DEPARTMENT TO DO SO.
- B.** THE CONTRACTOR MUST CALL THE CITY FOR AN INSPECTION AT LEAST TWENTY-FOUR HOURS BEFORE HE PLANS TO POUR THE CONCRETE. THE CONTRACTOR OR HIS FOREMAN MUST BE ON THE JOB WHEN THE INSPECTOR ARRIVES. IF, BECAUSE OF WEATHER CONDITIONS OR FOR SOME OTHER REASON, IT WILL NOT BE POSSIBLE TO HAVE A PERSON ON THE JOB, THE CONTRACTOR IS REQUIRED TO CALL AND CANCEL THE INSPECTION.
- C.** THE CONTRACTOR IS CAUTIONED AGAINST ORDERING CONCRETE BEFORE THE INSPECTION IS MADE DUE TO POSSIBLE CORRECTION OF FORMS OR GRADE.
- D.** THE CONTRACTOR SHALL PROVIDE PROTECTION AND TRAFFIC CONTROL BARRICADES, LIGHTS, SIGNS, AND OTHER DEVICES AS HEREIN SPECIFIED TO PROVIDE WARNING AND PROTECTION FOR VEHICULAR TRAFFIC, PEDESTRIANS, AND THE WORK DURING THE REMOVAL, CONSTRUCTION AND CURING OF SIDEWALK, CURB AND GUTTER, AND DRIVEWAY APRONS.
- E.** THE CONTRACTOR WILL BE RESPONSIBLE FOR AN IMMEDIATE REMOVAL AND CLEANUP OF ALL EXCAVATED MATERIAL. NO EXCAVATED MATERIAL SHALL BE STORED ON THE PAVEMENT.
- F.** ALL CONTRACTORS INSTALLING NEW CURB ARE CAUTIONED THAT IT IS THEIR RESPONSIBILITY TO REPAIR THE STREET PER CITY SPECIFICATIONS BEFORE REMOVING THEIR BARRICADES.

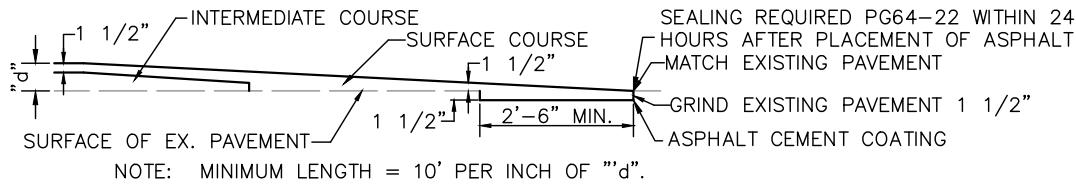

BUTT JOINT DETAIL

NOTE: MINIMUM LENGTH = 10' PER INCH OF "d".

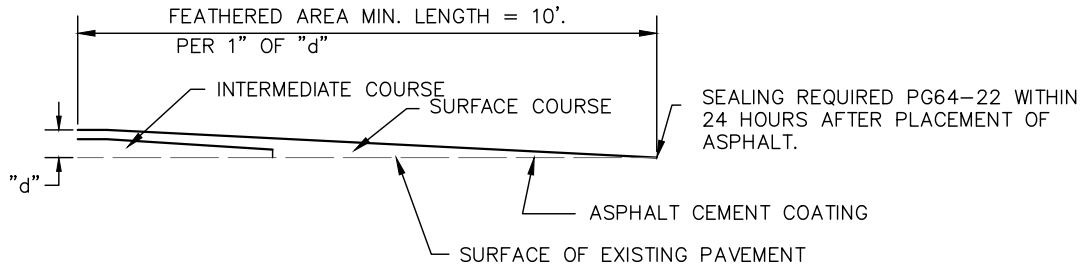

FEATHERING DETAIL

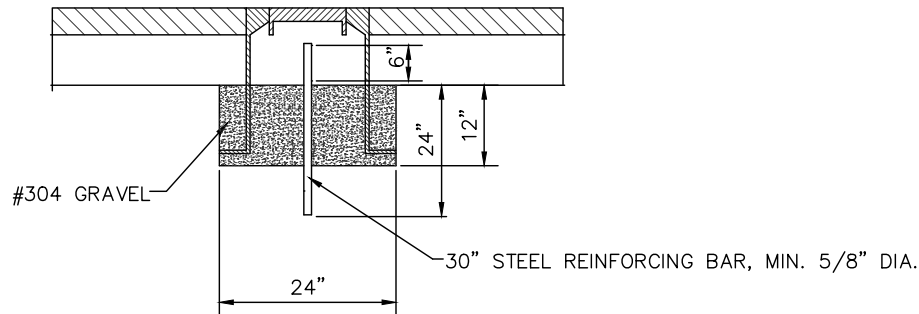

SURVEY MONUMENT DETAIL

MANHOLES ADJUSTED TO GRADE FOR OVERLAYS

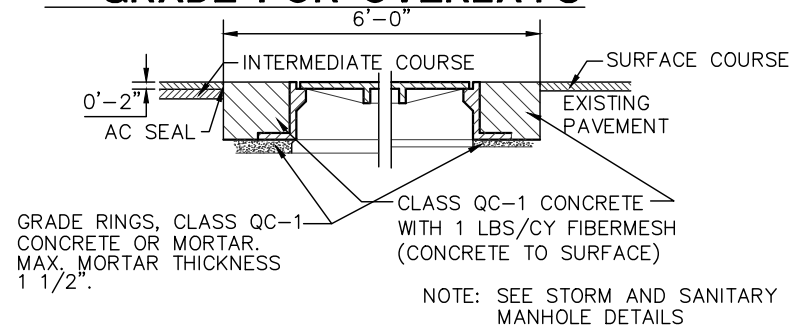

SURVEY MONUMENT NOTES

- A.** MONUMENT BOXES SHALL BE SET AT ALL STREET INTERSECTIONS AND CENTER POINTS OF CUL-DE-SACS. MONUMENT BOXES SHALL ALSO BE PLACED AT SECTION CORNERS OR OTHER SIGNIFICANT POINTS AT THE CITY'S DISCRETION, SO LONG AS THESE CORNERS OR POINTS LIE WITHIN THE PAVED ROADWAY.
- B.** MONUMENT BOXES SHALL BE PLACED ON THE P.C. & P.T. OF A SIMPLE CURVE, OR THE T.S. & S.T. OF A SPIRAL CURVE. IF THE P.I. OF A SIMPLE CURVE IS ACCESSIBLE WITHIN THE PAVED ROADWAY THEN A MONUMENT BOX SHALL BE PLACED AT THE P.I. THE P.C. & P.T. CAN THEN BE ELIMINATED.
- C.** MONUMENT BOXES NOTED IN PARAGRAPH B MAY BE ELIMINATED IF A LINE OF SIGHT (TAKING INTO ACCOUNT BOTH HORIZONTAL AND VERTICAL FACTORS) IS AVAILABLE WITHIN THE CURBS BETWEEN REQUIRED MONUMENT BOXES TO BE INSTALLED (SEE PARAGRAPH A). IF MONUMENT BOXES ARE ELIMINATED, THEN APPROVED MONUMENTS SHALL BE SET IN THEIR PLACE.
- D.** MONUMENT BOXES SHALL BE SET PRIOR TO THE LAYING OF SURFACE ASPHALT COURSE UNLESS OTHERWISE PREAPPROVED.
- E.** MONUMENT ASSEMBLIES SHALL BE EAST JORDAN IRON WORKS 8375 OR NEENAH R-1978-A2.
- F.** MONUMENT BOXES SHALL MEET THE REQUIREMENTS OF ODOT ITEM 611 UNLESS OTHERWISE SPECIFIED WITHIN.

GENERAL

A. FAILURE TO COMPLY WITH THE CONSTRUCTION STANDARDS AND DRAWINGS AND DESIGN CRITERIA WILL REQUIRE REMOVAL AND REPLACEMENT IN ACCORDANCE WITH THESE STANDARDS.

B. ALL STREET CONSTRUCTION SHALL BE IN ACCORDANCE WITH ODOT SPECIFICATIONS, LATEST REVISION.

C. CONSTRUCTION IMPROVEMENTS AFFECTING THE EXISTING CONDITION, PERFORMANCE AND LIFE CYCLE OF CITY STREETS, ALLEYS, OR RIGHTS-OF-WAY SHALL BE RESTORED TO THE REQUIREMENTS AND SATISFACTION OF THE CITY OF URBANA'S ENGINEERING DEPARTMENT. ALL CITY INFRASTRUCTURE SHALL BE ADEQUATELY RESTORED ACCORDING TO APPLICABLE STANDARDS AND DETAILS.

D. ALL NEW SUBDIVISIONS AND DEVELOPMENTS SHALL BE PROVIDED WITH PUBLIC SIDEWALK AND CURB AND GUTTER ON BOTH SIDES OF STREETS IN ACCORDANCE WITH CITY STANDARDS.

E. CURB CUTS FOR ALL NEW AND RECONSTRUCTED DRIVEWAYS SHALL CONFORM TO CITY STANDARDS. ALL NEW DRIVEWAY APPROACHES SHALL BE CONSTRUCTED OF CONCRETE AND SUBJECT TO ALL CITY REQUIREMENTS.

F. NO CITY STREET OR ALLEY SHALL BE CLOSED UNLESS THE CITY IS NOTIFIED A MINIMUM OF 48 HOURS IN ADVANCE OF A NON-EMERGENCY SITUATION. ADVANCED PUBLIC NOTIFICATION AND PUBLISHING SHALL BE A MINIMUM OF 24 HOURS.

PAVEMENT REPLACEMENT

A. IMMEDIATELY AFTER PLACEMENT OF BACKFILL IN EXISTING STREETS, A TEMPORARY PAVEMENT SHALL BE INSTALLED AND THE STREET OPENED. TEMPORARY PAVEMENT SHALL CONSIST OF 8" OF COMPACTED ODOT SPECIFICATION 411 OR 304. THE SURFACE SHALL BE MAINTAINED FLUSH WITH THE EXISTING STREET. COLD PATCH SHALL BE PLACED ON 411 OR 304 IN HIGH TRAFFIC AREAS AS DETERMINED BY THE CITY ENGINEER.

B. ANY SETTLEMENT OF A TRENCH CAUSING A DEPRESSION SHALL BE REFILLED AS REQUIRED BY THE CITY AT THE CONTRACTOR'S EXPENSE. THIS PROVISION IS APPLIED FOR A TWO YEAR PERIOD AFTER WORK IS ACCEPTED BY THE CITY.

C. ALL TEMPORARY PAVEMENT AND SIDEWALK SHALL BE MAINTAINED BY THE CONTRACTOR OR DEVELOPER AT HIS OWN EXPENSE IN A SUITABLE AND SAFE CONDITION FOR TRAFFIC UNTIL PERMANENT REPLACEMENT IS MADE OR THE PROJECT IS FINALLY ACCEPTED BY THE CITY.

TRAFFIC CONTROL

A. THE CONTRACTOR SHALL MAINTAIN TRAFFIC CONTROL AT ALL TIMES WITH THE PROPER DEVICES AS PER THE OHIO MANUAL OF UNIFORM TRAFFIC CONTROL DEVICES. THESE CONTROL DEVICES SHALL BE IN PLACE PRIOR TO ANY WORK COMMENCING. CONTRACTOR WILL BE RESPONSIBLE FOR ALL TRAFFIC CONTROL ITEMS.

B. TRAFFIC SHALL BE MAINTAINED AT ALL TIMES UNLESS OTHERWISE APPROVED BY THE CITY.

CURB STAKING AND ROADWAY

A. LINE AND GRADE EVERY 25' ON A CONVENIENT OFFSET WITH TACKED HUBS.

PAVEMENT (ASPHALT)

A. THE CONTRACTOR SHALL PROVIDE THE CITY WITH A COPY OF THE NORMAL (MEDIUM TRAFFIC) ODOT 448 JOB MIX FORMULA FOR EACH PLANT THAT PROVIDES HOT MIXED ASPHALT TO THE PROJECT. ALL MIXES SHALL FOLLOW ODOT JOB MIX FORMULA. RECYCLED ASPHALT SHALL NOT EXCEED 20% OF ANY 448 MIX PRODUCED. NO RECYCLED ASPHALT MAY BE USED IN THE ITEM 448 SURFACE COURSE.

B. THREE-WHEEL STEEL ROLLER OR EQUIVALENT SHALL BE USED FOR INITIAL BREAKDOWN ON ALL PROJECTS. THIS PROVISION SHALL BE FOR PLACING ASPHALT GREATER THAN 1-1/2" THICKNESS.

C. ALL WORK SHALL ADHERE TO ODOT'S LATEST REVISIONS AND TO THE CITY SPECIFICATIONS. THE MORE STRINGENT SHALL PREVAIL UNLESS OTHERWISE APPROVED.

D. PATCHED AREAS SHALL BE SEALED ON THE PERIMETER OF THE PATCH WITH ASPHALT CEMENT.

E. ALL UTILITY ADJUSTMENTS -- MANHOLES, WATER VALVES, ETC., -- SHALL BE RAISED TO FINISHED GRADE AFTER THE FINAL ASPHALT COURSE IS LAID, BUT WITHIN TWO WEEKS, UNLESS OTHERWISE APPROVED. PAVEMENT AROUND ADJUSTED UTILITIES SHALL BE REPLACED WITH SURFACE COURSE MATERIAL. NO CONCRETE TO SURFACE, UNLESS OTHERWISE APPROVED.

F. ASPHALT CEMENT SHALL BE USED NEXT TO THE LIP OF GUTTER PRIOR TO THE FINAL ASPHALT LIFT BEING PLACED. (SS-1 TACK OR PG64-22 SEAL.)

G. TACK COAT SHALL BE APPLIED PRIOR TO THE PLACEMENT OF THE FINAL LIFT OF ASPHALT IF THE EXISTING ASPHALT LIFT IS DIRTY OR AFTER TEN DAYS UNLESS OTHERWISE APPROVED. TEMPERATURE MUST BE 50°F OR HIGHER.

H. NO ASPHALT SHALL BE PLACED OVER EXCAVATED TRENCHES UNLESS OTHERWISE APPROVED. CONCRETE SHALL BE USED AS PER CITY CONSTRUCTION STANDARDS & DRAWINGS PAGE 1167.20.

I. NO ASPHALT SHALL BE LAID UNLESS THE CITY IS GIVEN PRIOR NOTICE AND THE AMBIENT TEMPERATURE IS 50°F OR GREATER UNLESS OTHERWISE APPROVED.

J. FINAL LIFT OF ASPHALT SHALL BE FINISHED TO 1/4" ABOVE THE LIP OF GUTTER.

K. TEMPERATURES FOR BREAKDOWN ROLLING SHALL BE 260°F TO 275°F AND FOR FINAL ROLLING 175°F TO 190°F.

L. ASPHALT CEMENT SHALL BE USED ON ALL JOINTS AND FEATHERED SURFACES PRIOR TO PLACEMENT OF THE NEXT COURSE OF ASPHALT TO THE ABUTTING JOINT, UNLESS OTHERWISE APPROVED.

M. 325°F IS THE MAXIMUM TEMPERATURE ASPHALT MATERIAL IS TO BE MIXED.

N. ALL EDGES TO BE TRIMMED BACK AND SAW CUT TO SOLID MATERIAL AND BE STRAIGHT AND NEAT AS PER THE CITY'S INSTRUCTIONS.

O. AREAS TO BE PAVED, OVERLAID OR PATCHED SHALL BE CLEAN AND FREE OF DEBRIS.

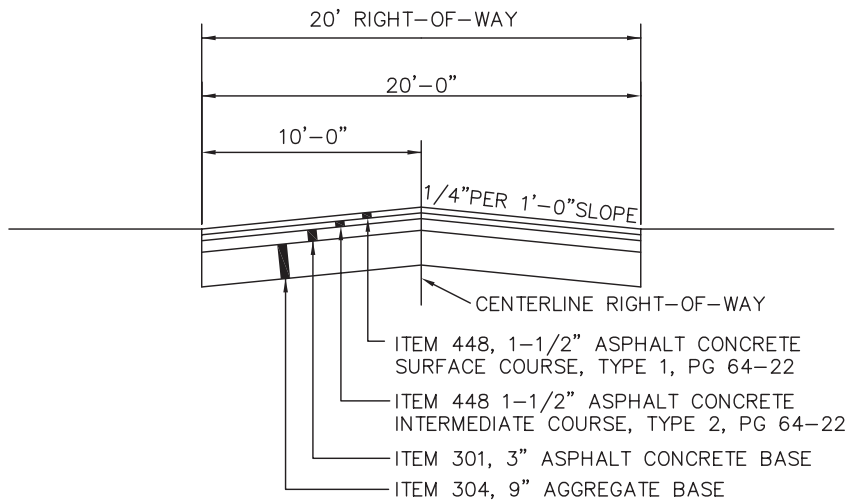

TYPICAL CROWN

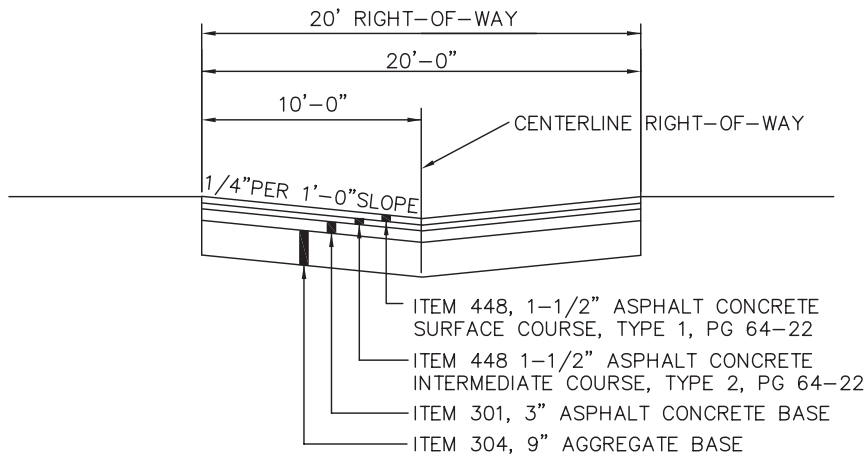

INVERTED CROWN

TYPICAL ALLEY CONSTRUCTION

- A. MINIMUM STANDARD (UNLESS OTHERWISE APPROVED).
- B. FOR RENOVATION OF EXISTING ALLEYS. NEW ALLEYS WILL BE APPROVED BY THE CITY.

ADJACENT PARKING AREAS SHALL BE CONNECTED TO LIMIT THE NUMBER OF ACCESS DRIVES TO THE STREET.

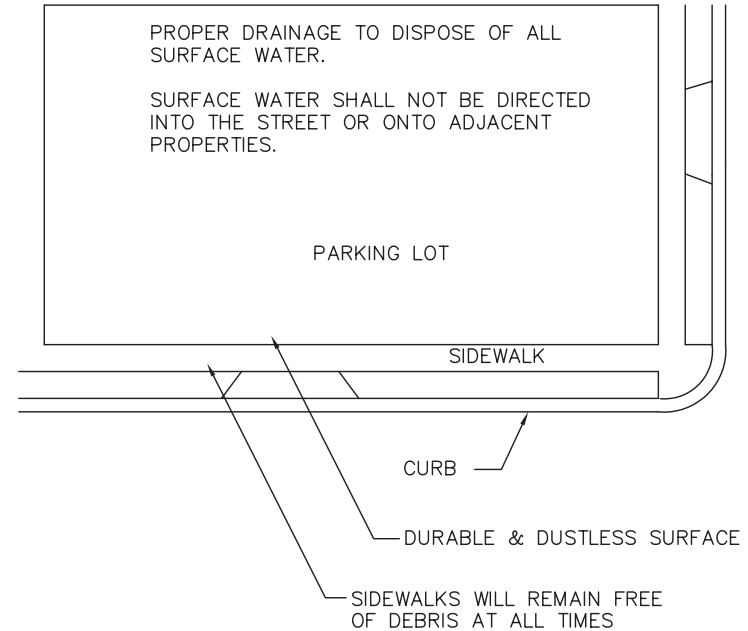

PARKING LOT DETAIL

THE FOLLOWING ARE ACCEPTED LOT SURFACES (UNLESS OTHERWISE APPROVED).

- A. DOUBLE CHIP AND SEAL, WITH APPROVAL.
- B. ASPHALT CONCRETE ITEM 448.
- C. CONCRETE.

NOTES

A. A PUBLIC RIGHT-OF-WAY OPENING PERMIT TO PERFORM ANY WORK ON OR WITHIN A PUBLIC RIGHT-OF-WAY, (STREET, ALLEY, ETC.) IS REQUIRED. A PERMIT IS REQUIRED FOR ANY TUNNEL, SIDEWALK, OPENING OR EXCAVATION UNDER OR IN THE RIGHT-OF-WAY OF PUBLIC GROUNDS.

B. PERMIT FORMS ARE AVAILABLE FROM THE CITY ENGINEERING DEPARTMENT. THE PERMIT FORM WILL BE COMPLETED BY THE PERSON OR FIRM PLANNING THE WORK WITHIN THE RIGHT-OF-WAY. ALL APPROVALS MUST BE OBTAINED BEFORE ANY WORK IS STARTED. 72 WORKING HOUR LEAD TIME IS RECOMMENDED.

C. THE APPLICANT SHALL HAVE SUFFICIENT BARRICADES, WARNING SIGNS, AND LIGHTS DURING THE ENTIRE PERIOD THAT THE WORK IS BEING PERFORMED AND SHALL ADHERE TO APPLICABLE SECTION OF THE OHIO MANUAL OF UNIFORM TRAFFIC CONTROL DEVICES.

D. A PERMIT FEE IS TO BE SET BY BOARD OF CONTROL AND IS POSTED IN THE CITY ENGINEER'S OFFICE, PAYABLE TO THE CITY OF URBANA.

E. THE EXISTING PAVEMENT SHALL BE NEATLY CUT PRIOR TO EXCAVATION. ALL EXCAVATED MATERIAL SHALL BE REMOVED FROM THE JOB SITE. THE APPLICANT IS RESPONSIBLE FOR ALL PAVEMENT DAMAGED OUTSIDE THE TRENCH AREA.

F. ALL EXCAVATIONS OR TRENCH EDGES UNDER OR WITHIN 5' OF PROPOSED OR EXISTING PAVEMENT, CURB, DRIVEWAYS, ALLEYS, STONE AREAS OR WALKS SHALL BE BACKFILLED WITH ODOT 703 WASHED GRAVEL, #8, #57, OR #67. AC SEALER IS TO BE APPLIED TO ALL EDGES AFTER CONCRETE IS COMPLETED. ON STATE AND U.S. ROUTES AND ANY OTHER HEAVILY TRAVELED ROUTE THE CITY DESIGNATES, THE TOP 8" SHALL BE REPLACED WITH ODOT CLASS QC FS HIGH EARLY STRENGTH CONCRETE (400 PSI FLEXURAL STRENGTH AT 4 HOURS, 900 LB/CY CEMENT). ON ALL OTHER STREETS, THE TOP 6" SHALL BE REPLACED WITH ODOT CLASS QC 1 CONCRETE (4000 PSI AT 28 DAYS, 520 LB/CY CEMENT AND POZZOLAN MATERIALS). TYPE QC FS CONCRETE SHALL HAVE A MINIMUM OF 24 HOURS CURE TIME AND TYPE QC 1 SHALL HAVE A MINIMUM OF 3 DAYS CURE TIME BEFORE OPENING TO TRAFFIC.

G. ALL EXCAVATION OR TRENCH EDGES NOT UNDER OR WITHIN 5' OF PROPOSED OR EXISTING PAVEMENT, CURB, DRIVEWAYS, ALLEYS, STONE AREAS OR WALKS CAN BE COMPACTED WITH EXISTING NATIVE MATERIAL IN 12" MAXIMUM LIFTS OR AS APPROVED BY THE CITY.

H. SIDEWALKS, CURBS AND DRIVEWAYS SHALL BE REPLACED IN ACCORDANCE WITH NEW CONSTRUCTION IN COMPLIANCE WITH THESE STANDARDS. CONTRACTOR SHALL NOTIFY THE CITY ENGINEERING DEPARTMENT FOR INSPECTION AFTER FORMS ARE SET AND BEFORE CONCRETE IS ORDERED. TWENTY-FOUR HOUR LEAD TIME IS RECOMMENDED.

I. GRASSED AREAS SHOULD BE BROUGHT TO LEVEL WITH A MINIMUM OF 6 INCHES OF TOP SOIL THEN SEEDED OR SODDED. IF SEEDED, USE AN ODOT CLASS 1 MIX TYPE OR EQUIVALENT WITH A 19-19-19 STARTER FERTILIZER. STRAW THE AREA AFTERWARDS.

J. ALL DISTURBED AREAS MUST BE RETURNED TO AS GOOD OR BETTER CONDITION. ALL REPAIRS MUST MEET CITY SPECIFICATIONS. THE CITY MUST INSPECT AND APPROVE ALL REPAIRS.

K. IN HIGH TRAFFIC AREAS, COLD PATCH SHALL BE PLACED TO 1-1/2" THICKNESS OVER BACKFILLED TRENCH WITHIN ONE WORKING DAY AFTER THE BACKFILL HAS BEEN COMPACTED, IF THE CONCRETE PAVEMENT ISN'T PLACED IMMEDIATELY. IF CONCRETE PAVEMENT IS PLACED IMMEDIATELY, A LOW STRENGTH MORTAR BACKFILL SHALL BE REQUIRED AT THE DISCRETION OF THE CITY ENGINEER IN EXCHANGE FOR GRAVEL BACKFILL.

L. THE PUBLIC RIGHT-OF-WAY OPENING PERMIT SHALL CARRY A 2-YEAR WARRANTY FROM THE DATE OF ACCEPTANCE FOR ALL CONCRETE RESTORATIONS. ANY TRENCH SETTLEMENT CAUSING A DEPRESSION GREATER THAN OR EQUAL TO 3/4" OF ANY PORTION OF THE PATCH MAY BE REPAIRED BY THE CITY AT ITS DISCRETION. THE CONTRACTOR SHALL THEN BE BILLED AND, IF AFTER 30 DAYS NON PAYMENT, THE CITY MAY ASSESS THE PROPERTY OWNER'S TAXES.

**CITY OF
URBANA**

PUBLIC RIGHT-OF-WAY OPENING AND EXCAVATION

REVISIONS:	DATE
01-13-09	APPROVED:
07-02-09	01-13-06
12-20-12	PAGE No.
01-08-16	1167.16
04-10-19	

EXAMPLE 'A'

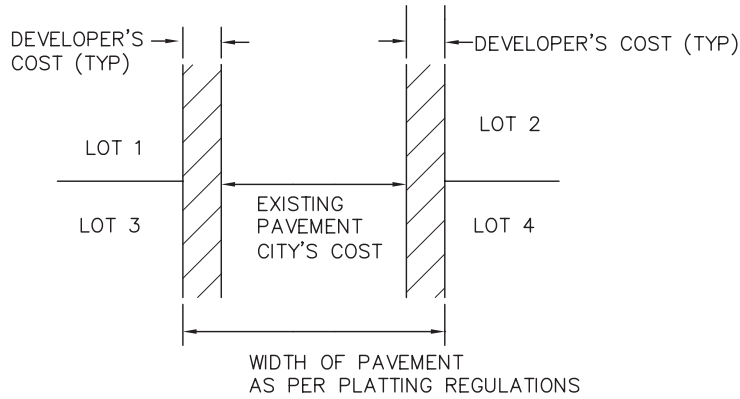

STREET IMPROVEMENTS FROM EXISTING STREET WIDTH TO PLATTING REGULATION WIDTH

EXAMPLE 'B'

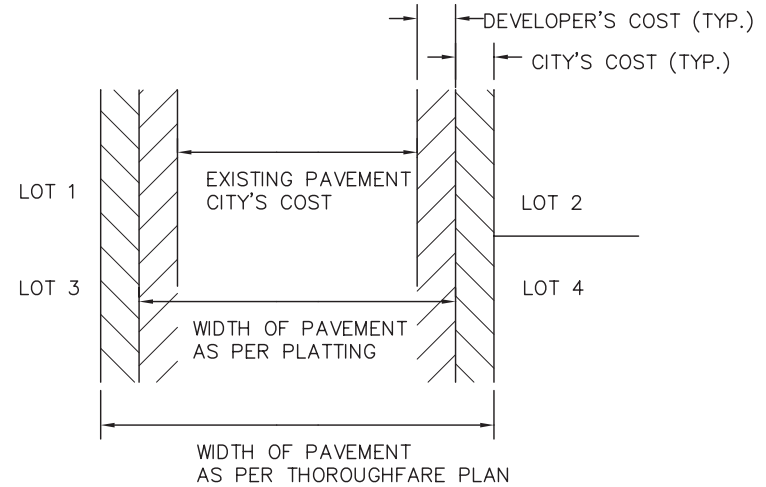

STREET IMPROVEMENTS FROM EXISTING STREET WIDTH TO THOROUGHFARE PLAN WIDTH

NOTES

- A.** IF BOTH SIDES OF A STREET ARE INCLUDED IN THE SUBDIVISION, THE DEVELOPER PAYS THE TOTAL COST FOR ADDITIONAL WIDTH OF EXCAVATION, PAVEMENT, CURB AND SIDEWALK INCLUDING COST TO BRING THE STORM SEWER SYSTEM UP TO STANDARDS.
- B.** IF ONE SIDE OF THE SUBDIVISION ABUTS AN EXISTING STREET, THE DEVELOPER SHALL PAY FOR THE TOTAL COST OF ONE SIDE FOR ADDITIONAL WIDTH OF EXCAVATION, PAVEMENT, CURB AND SIDEWALK INCLUDING COST TO BRING THE STORM SEWER SYSTEM UP TO STANDARDS.
- C.** THE CITY PAYS CONSTRUCTION COST ON EXISTING STREET WIDTH AND ANY OVERSIZING TO MEET THOROUGHFARE PLAN.

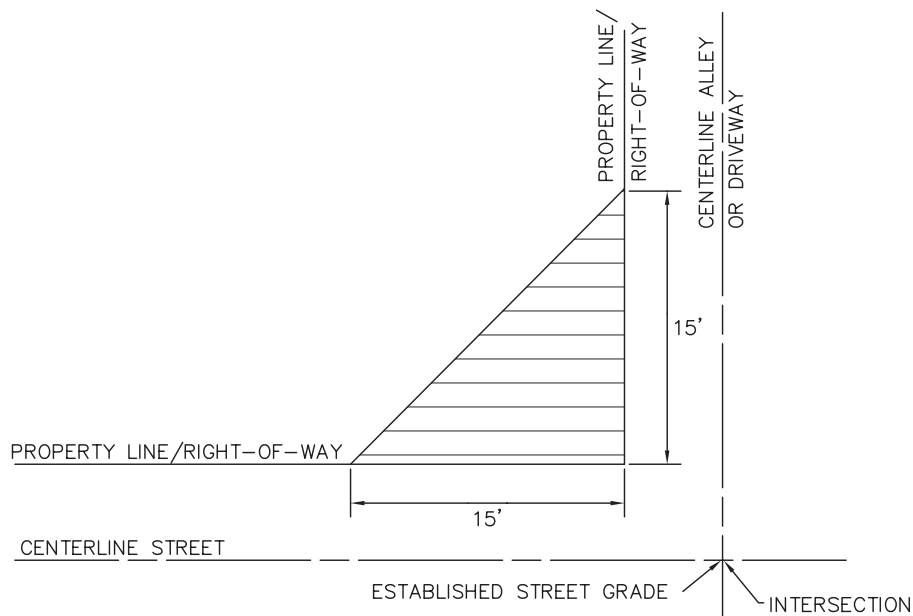

STREET AND ALLEY OR DRIVEWAY INTERSECTION

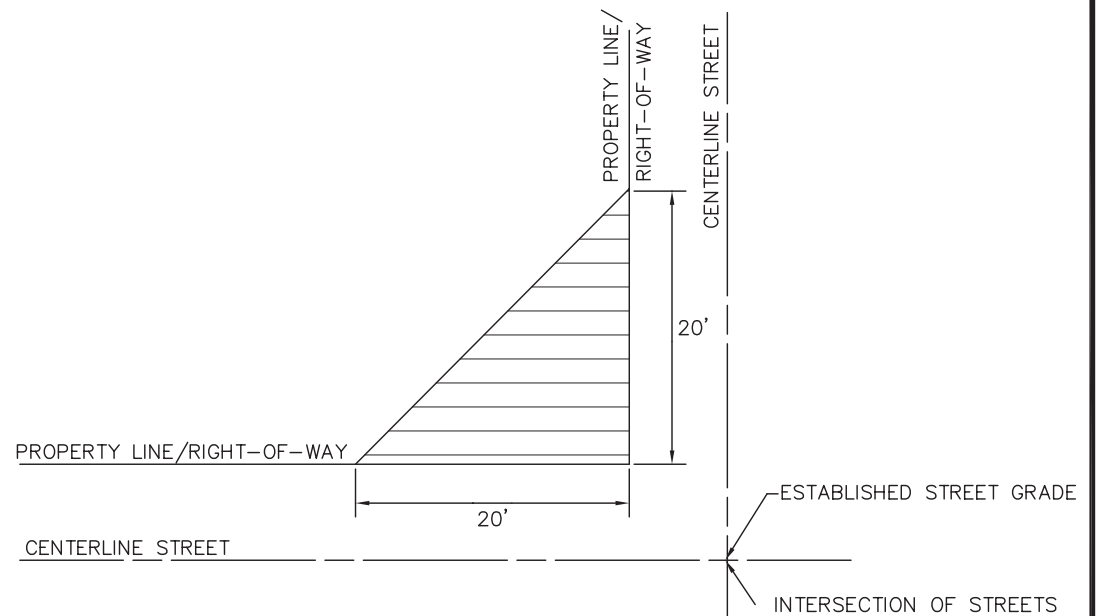

STREET AND STREET INTERSECTION

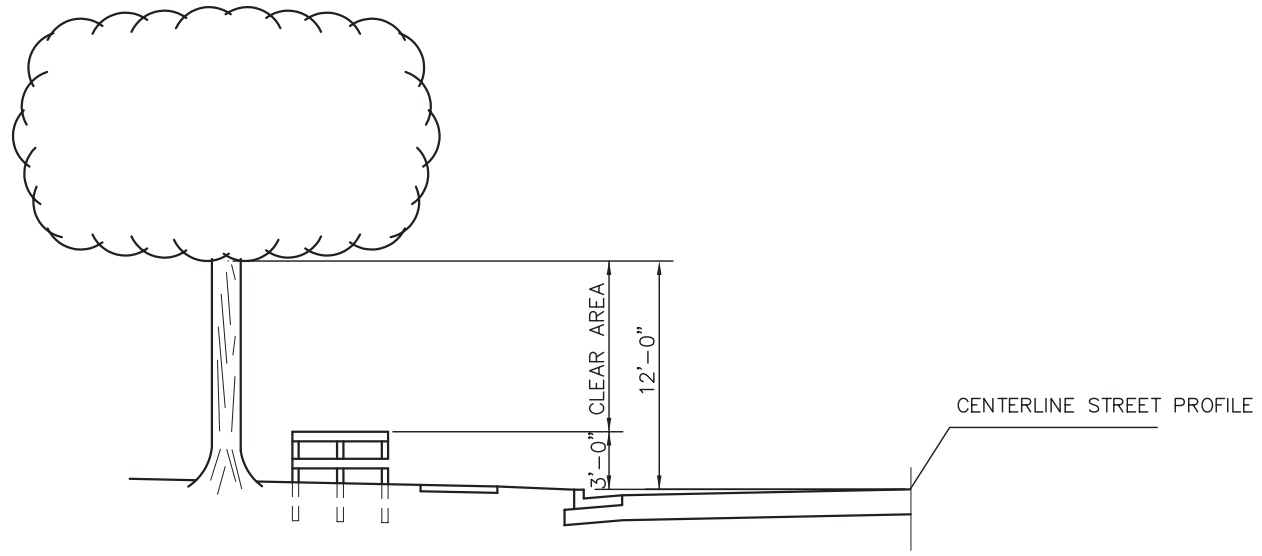

VISION CLEARANCE EXHIBIT

NOTES

THERE SHALL BE NOTHING ABOVE 3' OR BELOW 12' OF THE ESTABLISHED STREET GRADE IN THE TRIANGULAR SHADED AREA.

(OW-134)
ROAD WORK
AHEAD



(OW-121)
ONE-LANE ROAD
AHEAD



(OW-125)
FLAGMAN AHEAD



FLAGMAN

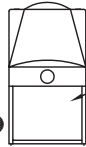

WORK VEHICLE



STANDARD DRUM OR
TYPE 1 BARRICADE



FLAGMAN



(OW-125)
FLAGMAN AHEAD



(OW-121)
ONE-LANE ROAD
AHEAD



(OW-134)
ROAD WORK
AHEAD

NOTES

- A.** THE POLICE AND FIRE DEPARTMENTS SHALL BE NOTIFIED 24 HOURS IN ADVANCE OF ANY CONSTRUCTION. NO STREET SHALL BE CLOSED WITHOUT THE APPROVAL OF THE CITY.
- B.** IF THE WORK IS TO COVER THE ENTIRE WIDTH OF THE STREET, ONE HALF OF THE STREET SHALL BE MAINTAINED FOR TRAFFIC WHILE ONE HALF OF THE STREET IS REPAIRED.
- C.** BARRICADE DISTANCE AND SEPARATION OF WARNING TO BE SPACED AS PER JOB SITE ACCORDING TO THE CITY.
- D.** IF BARRICADES ARE TO BE LEFT UP OVERNIGHT, WARNING LIGHTS (FLASHERS) ARE TO BE USED.
- E.** ALL STREET CONTROL DEVICES APPLICABLE TO DIFFERENT WIDTH STREETS, TYPE OF CONSTRUCTION, ETC., SHALL CONFORM TO THE LATEST REVISION OF THE OHIO MANUAL OF UNIFORM TRAFFIC CONTROL DEVICES, UNLESS OTHERWISE APPROVED BY THE CITY AND SHALL BE IN PLACE AND PROPERLY DISPLAYED PRIOR TO THE COMMENCEMENT OF ANY WORK.

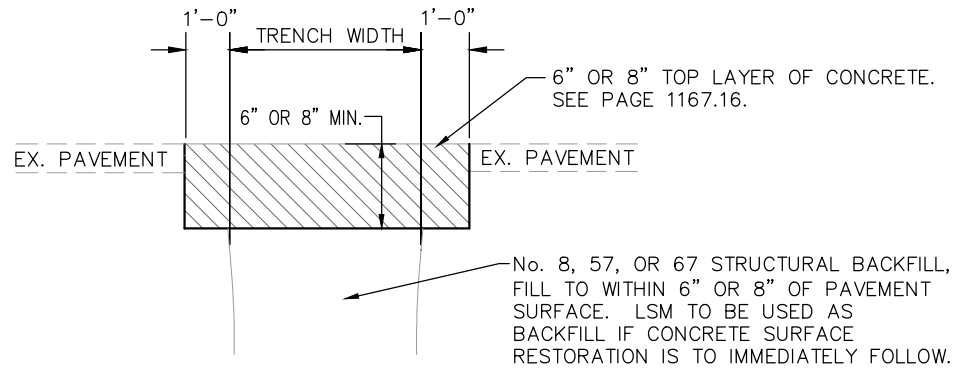

TYPICAL PAVEMENT RESTORATION DETAIL

TYPICAL PAVEMENT RESTORATION NOTES

SOIL BORINGS SHALL BE CAPPED WITH A MINIMUM OF 8" OF ODOT CLASS QC FS CONCRETE, ON STATE OR U.S. ROUTES OR 6" OF ODOT CLASS QC 1 CONCRETE ON ALL OTHER STREETS.

ACCESSIBLE PARKING SPACES FOR CARS

SIGN WITH INTERNATIONAL SYMBOL OF ACCESSIBILITY MOUNTED 6' ABOVE THE PAVEMENT ON BOTH SIDES OF 5' AISLE.

TYPICAL ACCESSIBLE PARKING SPACE 9' X 19' MINIMUM

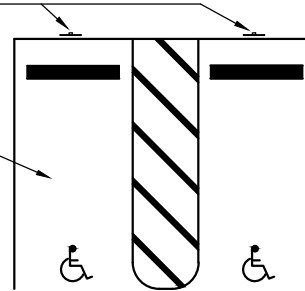

CURB-SIDE ACCESSIBLE PARKING SPACES

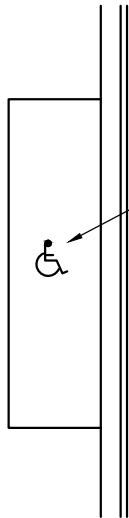

SIGN WITH INTERNATIONAL SYMBOL OF ACCESSIBILITY MOUNTED 6' ABOVE THE PAVEMENT.

TYPICAL CURB-SIDE PARKING SPACE 8' X 23' MINIMUM

TYPICAL ACCESSIBLE PARKING AISLE 5' X 19' MINIMUM

VAN-ACCESSIBLE PARKING SPACES

SIGN WITH "VAN ACCESSIBLE" AND THE INTERNATIONAL SYMBOL OF ACCESSIBILITY MOUNTED 6' ABOVE THE PAVEMENT ON LEFT SIDE OF 8' AISLE.

SIGN WITH INTERNATIONAL SYMBOL OF ACCESSIBILITY MOUNTED 6' ABOVE THE PAVEMENT ON RIGHT SIDE OF 8' AISLE.

TYPICAL VAN ACCESSIBLE PARKING SPACE 9' X 19' MINIMUM

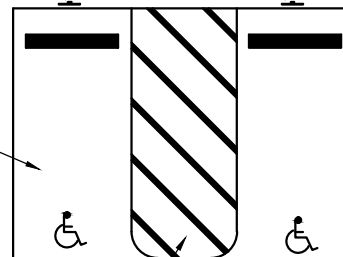

TYPICAL VAN ACCESSIBLE PARKING AISLE 8' X 19' MINIMUM

NOTES

A. AN ACCESSIBLE ROUTE MUST ALWAYS BE PROVIDED FROM THE ACCESSIBLE PARKING TO THE ACCESSIBLE ENTRANCE. ACCESSIBLE PARKING SPACES SHOULD BE LOCATED ON THE SHORTEST ACCESSIBLE ROUTE OF TRAVEL TO AN ACCESSIBLE FACILITY ENTRANCE, WHENEVER POSSIBLE. THE MAXIMUM PAVEMENT SLOPE IS TO BE 2% (1:50) IN ALL DIRECTIONS IN PARKING STALL AND AISLE AREAS. THE MAXIMUM SLOPE ALONG THE ACCESSIBLE ROUTE SHALL NOT BE GREATER THAN 1:12 IN THE DIRECTION OF TRAVEL. AN ACCESSIBLE ROUTE NEVER HAS CURBS OR STEPS, MUST BE A MINIMUM OF 3' IN WIDTH, AND MUST HAVE A FIRM, STABLE, SLIP-RESISTANT SURFACE. HANDRAILS MUST BE PROVIDED ALONG THE ACCESSIBLE ROUTE WHERE THE SLOPE IS MORE THAN 1:20 AND THE VERTICAL RISE IS GREATER THAN 6". THERE CAN BE NO DROPOFFS ALONG THE EDGES OF THE ACCESSIBLE ROUTE.

B. THE AISLE DIMENSIONS ARE TO BE 5' X 19' MINIMUM FOR ACCESSIBLE PARKING SPACES FOR CARS AND 8' X 19' FOR VAN ACCESSIBLE PARKING SPACES. ALL PARKING STALLS ARE TO BE 9' X 19' MINIMUM EXCEPT CURB-SIDE SPACES WHICH SHALL BE 8' X 23' MINIMUM.

C. A HANDICAP SYMBOL SHALL BE PAINTED AT THE END OF ALL HANDICAP PARKING SPACES IN PARKING LOTS AND IN THE CENTER OF CURB-SIDE ACCESSIBLE PARKING SPACES. THE MINIMUM SIZE SHALL BE 28".

D. IF THE TOTAL NUMBER OF PARKING SPACES IN THE PARKING AREA IS BETWEEN 1 AND 100, THERE SHALL BE 1 HANDICAP PARKING SPACE PROVIDED PLUS ONE HANDICAP PARKING SPACE PER 25 PARKING SPACES. IF THE TOTAL NUMBER OF PARKING SPACES IN THE PARKING AREA IS BETWEEN 101 AND 200, THERE SHALL BE 5 HANDICAP PARKING SPACES PROVIDED PLUS ONE HANDICAP PARKING SPACE PER EACH 50 PARKING SPACES OVER 100. IF THERE ARE OVER 200 PARKING SPACES IN THE PARKING AREA, THERE SHALL BE 6 HANDICAP PARKING SPACES PROVIDED PLUS ONE HANDICAP PARKING SPACE PER EACH 75 PARKING SPACES OVER 200. THERE SHALL BE A MINIMUM OF ONE VAN ACCESSIBLE PARKING SPACE AND ONE 8' AISLE PROVIDED IN ALL PARKING AREAS.



EXAMPLE: Settlement / Vertical Offset

1.) CURB AND/OR GUTTER HAVING DIFFERENTIAL SETTLEMENT OR HEAVING AT JOINTS THAT CREATE A VERTICAL OFFSET OF 1 INCH OR MORE AT ANY POINT ALONG A JOINT, OR MULTIPLE JOINT GAPS GREATER THAN 2 INCHES.



EXAMPLE: Extreme Slope

2.) CURB AND/OR GUTTER HAVING A SLOPE OF MORE THAN 2 INCHES PER FOOT IN ANY DIRECTION FROM A ROAD OR NATURAL GRADE THAT CREATES A DISCONTINUATION IN THE CURB OR GUTTER.



EXAMPLE: Large Holes in Surface

3.) CURB AND/OR GUTTER HAVING HOLES OR DEPRESSIONS IN THE SURFACE THAT ARE IN EXCESS OF 1 FOOT BY 1 FOOT BY 1 INCH DEEP.



EXAMPLE: Deteriorated

4.) THE SURFACE OF A CURB AND/OR GUTTER HAVING 25% OR GREATER OF ITS LENGTH CONTINUOUSLY SPALLED, CRACKED OR DETERIORATED WITHIN A 10 FOOT POURED SECTION.



EXAMPLE: Exposed aggregate

5.) CURB AND/OR GUTTER SECTIONS THAT HAVE CRUSHED STONE OR GOUGES THAT CONTINUOUSLY EXPOSE AGGREGATE FOR 25% OR MORE WITHIN A 10 FOOT POURED SECTION.



EXAMPLE: Asphalt repairs

6.) CURB AND/OR GUTTER SECTIONS THAT HAVE BEEN PREVIOUSLY PATCHED OR PAVED WITH AN ASPHALTIC MATERIAL OR MATERIALS OTHER THAN CONCRETE OF 25% OR MORE WITHIN A 10 FOOT POURED SECTION. (THIS DOES NOT INCLUDE A STREET OR SECTION OF A STREET ORIGINALLY INSTALLED OR RECONSTRUCTED WITH ASPHALT CURBING AND/OR GUTTER.



EXAMPLE: Holding Water

7.) CURB AND/OR GUTTER SECTIONS THAT HAVE SETTLED, CAUSING THE SURFACE TO HOLD LARGE AMOUNTS OF WATER AFTER A RAINFALL (2 INCHES OR MORE DEEP OVER A 20 FOOT SECTION) OR THAT ARE TILTED OR SETTLED SO AS TO RESTRICT STORM WATER DRAINAGE WITHIN A 10 FOOT POURED SECTION.



EXAMPLE: Grass/Weed Growth

8.) CURB AND/OR GUTTER SECTIONS THAT HAVE MISSING CONCRETE, BEEN REMOVED OR DETERIORATED SO AS TO HAVE SOILS AND/OR GRASS/WEEDS GROWING IN ITS PLACE AT 25% OR MORE WITHIN A 10 FOOT SECTION.



EXAMPLE: Low Curb Reveal

9.) CURB AND/OR GUTTER SECTIONS THAT HAVE SETTLED OR HAVE BEEN BUILT UP WITH ASPHALT OVER TIME SO THAT LESS THAN 2 INCHES OF THE CURB IS REVEALED ABOVE THE PAVEMENT AND ASPHALT GRINDING IS NOT A SOLUTION TO IMPROVE THE REVEAL.



EXAMPLE: Sidewalk to Pavement

10.) CURB AND GUTTER SECTIONS THAT ARE COMBINED WITH SIDEWALK WILL NOT BE REBUILT OR REPAIRED IF THE SIDEWALK IS IN GOOD REPAIR, EVEN IF THE CURB REVEAL IS LOW. OTHER CURB DEFICIENCIES, WHILE PART OF THE SIDEWALK, WILL BE REPAIRED ONLY IF RECOMMEND BY THE CITY ENGINEER.



EXAMPLE: Filled Gutter

11.) CURB AND/OR GUTTER SECTIONS THAT HAVE BEEN FILLED IN AS TO PREVENT THE FLOW OF STORM WATER WITHIN THE NORMAL FLOW LINE OF THE GUTTER.

12.) IF OVER 75% OF THE PROPERTY OWNER'S CURB AND/OR GUTTER MEETS THE REPLACEMENT CRITERIA AND THE REMAINING IS LESS THAN 20 FEET IN LENGTH AND HAS SOME DAMAGE OR DISCONTINUITY WITH THE PROPOSED, THE REMAINING CURB AND GUTTER MAY BE REPLACED AS WELL.

13.) THE CITY ENGINEER, AT HIS/HER DISCRETION, MAY REQUIRE THAT ADDITIONAL CURB AND GUTTER BE REPLACED IF: a) CONTINUED AND IMMEDIATE STRUCTURAL DAMAGE IS LIKELY TO OCCUR WITHOUT REPLACEMENT; b) A SECTION OF CURB AND GUTTER IS DETERMINED TO BE HAZARDOUS; c) DAMAGE TO THE ROADWAY IS BEING INCURRED ON ACCOUNT OF THE CURB AND GUTTER

14.) CURB AND GUTTER "SPOT" REPLACEMENTS, AS SELECTED ACCORDING TO CITY REPLACEMENT STANDARDS, WILL BE A SUBSET OF THE ANNUAL CITY STREET RESURFACING PROGRAMS. NO OTHER CURB AND GUTTER IMPROVEMENTS WILL BE PLANNED BY THE CITY, EXCEPT IN EMERGENCY SITUATIONS OR DURING PROJECT CONSTRUCTION OR RECONSTRUCTION.

CITY STREET LIGHTS

CITY STREET LIGHTS USED IN RESIDENTIAL AREAS ARE TO BE MANUFACTURED BY HOLOPHANE. THEY ARE TO HAVE THE GRANVILLE SERIES LUMINARIES LEAF STYLE HOUSING TYPE B WITH THE CHESAPEAKE SERIES CAST ALUMINUM TYPE A POST CP 12C/18, 12' HIGH, CA/DG CAST ALUMINUM, DARK GREEN. SPACING IS TO BE AT 100' ALTERNATING SIDES OF THE STREET (200' SPACING ON EACH SIDE) USING A CREE, 65 WATT, 4000K COLOR TEMPERATURE LED SYSTEM WITH A VOLTAGE RANGE OF 120-277V (BXRAAA33-UD7). A TYPE III LIGHT DISTRIBUTION IS DESIRED IN THIS CASE.

CITY STREET LIGHTS USED IN THE URBANA CORRIDOR OVERLAY DISTRICT AND HERITAGE OVERLAY DISTRICT ARE TO BE MANUFACTURED BY HOLOPHANE. THEY ARE TO HAVE THE GRANVILLE SERIES LUMINARIES LEAF STYLE HOUSING TYPE B WITH THE CHESAPEAKE SERIES CAST ALUMINUM TYPE A POST CP 12C/18, 12' HIGH, CA/DG CAST ALUMINUM, DARK GREEN. SPACING IS TO BE AT 75' ALTERNATING SIDES OF THE STREET (150' SPACING ON EACH SIDE) USING A CREE, 65 WATT, 4000K COLOR TEMPERATURE LED SYSTEM WITH A VOLTAGE RANGE OF 120-277V (BXRAAA53-UD7) AND RS/GFI/WPC, WET-WHILE-IN-USE COVERED RECEPTACLE LOCATED TOWARDS THE TOP OF THE POST. A TYPE V LIGHT DISTRIBUTION PATTERN SHALL BE USED IN THIS CASE.

AN ACCEPTABLE ALTERNATIVE TO HOLOPHANE IS MAIN STREET LIGHTING. THEY ARE TO HAVE THE SERIES 4 GLASS GLOBE TYPE E LEAF STYLE HOUSING WITH THE OLD NORFOLK III SERIES CAST ALUMINUM BASE AND EXTRUDED ALUMINUM, FLUTED SHAFT, 12' HIGH, 13 3/4" BASE DIAMETER, FOREST GREEN. SPACING AND LIGHT DISTRIBUTION PATTERN ARE TO BE AS DESCRIBED ABOVE USING A MATECH, D4, 60 WATT, 4000K COLOR TEMPERATURE LED SYSTEM WITH A VOLTAGE RANGE OF 120-277V AND RS/GFI/WPC, WET-WHILE-IN-USE COVERED RECEPTACLE LOCATED TOWARDS THE TOP OF THE POST (NO RECEPTACLE IN RESIDENTIAL AREAS).

CITY MAST ARM SUPPORTS

ALL NEW TRAFFIC SIGNALS SHALL BE SUPPORTED USING ODOT TC-81.20 STANDARD MAST ARMS, DESIGNED BY SIZE, AND PAINTED WITH THE INTERIOR AIR SPRAYED WITH A RUST INHIBITIVE WAX BASE COATING. THE OUTSIDE SHALL BE SANDBLASTED TO SSPC-SP6 COMMERCIAL BLAST CLEANING AND PRIMED WITH A HI-BUILD PRIMER AT 3-4 MILS DRY FILM. THE OUTSIDE SHALL HAVE A FINISH COAT OF POLYESTER POWDER COAT SYSTEM 1-2 MILS DRY FILM. COLOR IS TO BE DARK GREEN MANUFACTURED BY TIGER DRYLAC, CATALOG #RAL 6005.

CITY TRAFFIC SIGNAL AND PEDESTRIAN HEADS

ALL NEW SIGNAL HEADS SHALL BE YELLOW PLASTIC HOUSING WITH 12" LED AND GLASS LENS AS MANUFACTURED BY GELCORE. ALL NEW PEDESTRIAN SIGNAL HEADS ARE TO BE TYPE A2 BLACK ALUMINUM HOUSING USING INTERNATIONAL SYMBOLS. ALL BRACKET ARMS AND MOUNTING MATERIALS ARE TO BE PAINTED WITH TIGER DRYLAC, CATALOG #RAL 6005, DARK GREEN TO MATCH THE MAST ARMS AS DESCRIBED ABOVE.

CITY TRAFFIC SIGNAL CONTROLLER AND CONFLICT MONITOR

ALL NEW TRAFFIC SIGNAL CONTROLLERS ARE TO BE ASC/25-1000 NEMA 2, TYPE 1 CONTROLLERS AS MANUFACTURED BY ECONOLITE. ALL CONFLICT MONITORS ARE TO BE EDI MMU-16E.

LOOP DETECTOR UNITS

ALL NEW LOOP DETECTOR UNITS SHALL BE POWERHEAD TWO CHANNEL, DELAY AND EXTENSION TYPE.

TRAFFIC CONTROL DEVICES, STREET SIGNS, AND POSTS

ALL NEW TRAFFIC CONTROL DEVICES SHALL BE PER THE LATEST REVISION OF THE MANUAL OF UNIFORM TRAFFIC CONTROL DEVICES FOR STREETS AND HIGHWAYS AND APPROVED BY THE CITY ENGINEER PRIOR TO INSTALLATION. ALL SIGN POSTS SHALL BE STANDARD STEEL POSTS UNLESS OTHERWISE APPROVED BY THE CITY. STREET NAME SIGNS SHALL HAVE A WHITE BACKGROUND WITH A BLACK BORDER AND BLACK, D SERIES, LETTERING. THE SIGN SHALL HAVE A THICKNESS OF 0.08" AND BE DOUBLE SIDED. THE BLADE MUST BE 8" TALL WITH 4" UPPERCASE AND LOWERCASE LETTERS FOR SIGNS ALONG SIDE STREETS AND 12" TALL WITH 6" UPPERCASE AND LOWERCASE LETTERS FOR SIGNS ALONG STATE AND U.S. ROUTES. THE PREFIXES AND SUFFIXES SHALL BE 3" FOR SIGNS WITH 4" UPPERCASE LETTERING AND 4" FOR SIGNS WITH 6" UPPERCASE LETTERING.

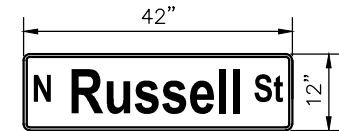
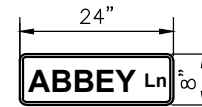

CITY BENCHES

CITY BENCHES ARE TO BE MANUFACTURED BY DUMOR, INC., TYPE #119-60, 6' BENCH, COLOR #30-6387 HUNTER GREEN.

CITY TRASH RECEPTACLES

CITY TRASH RECEPTACLES ARE TO MANUFACTURED BY DUMOR, INC., #84-32, 32 GALLON, COLOR #30-6387 HUNTER GREEN.

DEMOLITION PERMIT REGULATIONS

DEMOLITION PERMIT SHALL BE OBTAINED FROM THE CHAMPAIGN COUNTY BUILDING REGULATIONS.

SEEDING

A. ALL AREAS DESIGNATED FOR SEEDING SHALL HAVE A MINIMUM OF 6" OF TOPSOIL OVER THE ENTIRE AREA. THE AREA SHALL BE RAKED, ROLLED, AND DRESSED READY FOR SEEDING. NO STONE OVER 1" IN SIZE PERMITTED.

TREE PLANTING IN PUBLIC RIGHT-OF-WAY

A. ALL TREES PLANTED IN THE PUBLIC RIGHT-OF-WAY AS SET FORTH IN CHAPTER 905 OF THE URBANA REVISED CODE.

DRAINS

A. ALL FIELD OR STORM DRAINS WHICH ARE ENCOUNTERED DURING CONSTRUCTION SHALL BE REPAIRED AND PROVIDED WITH UNOBSTRUCTED OUTLETS AS APPROVED AND DIRECTED BY THE CITY AND MARKED ON THE RECORD DRAWINGS.

CONNECTIONS TO EXISTING PIPE

A. WHERE THE PLANS PROVIDE FOR PROPOSED CONDUIT TO BE CONNECTED TO, OR TO CROSS EITHER OVER OR UNDER AN EXISTING SEWER, IT SHALL BE THE RESPONSIBILITY OF THE CONTRACTOR TO LOCATE THE EXISTING PIPE BOTH AS TO LINE AND GRADE BEFORE STARTING TO LAY THE PROPOSED CONDUIT.

UTILITY SEPARATION

A. ANY UNDERGROUND UTILITIES SUCH AS GAS, ELECTRIC, CABLE TV, TELEPHONE, ETC., SHALL HAVE 10' SEPARATION FROM ANY CITY UTILITY UNLESS OTHERWISE APPROVED.

UTILITIES

A. THE MAXIMUM LENGTH OF ANY UTILITY TRENCH TO BE OPEN AT ANY TIME SHALL BE 100' UNLESS OTHERWISE APPROVED.

COMPACTION METHODS

A. FLOODING SHALL NOT BE PERMITTED.

B. MECHANICAL DEVICES, HAND DEVICES, VIBRATING PLATES OR OTHER EQUIPMENT APPROVED BY THE CITY ARE ACCEPTABLE 1' ABOVE PIPE IN UNIFORM LIFTS OF 12" (LOOSE DEPTH) OF EXISTING NATIVE MATERIAL AND 6" OF GRANULAR BACKFILL. THE HEIGHT OF LIFTS WILL DEPEND UPON THE TYPE OF MECHANICAL EQUIPMENT BEING USED. THE HEIGHT WILL BE 6" FOR HAND OPERATED TOOLS AND UP TO 12" ON EQUIPMENT MOUNTED TOOLS. THE COMPACTION EQUIPMENT SHALL BE CAPABLE OF COMPACTING THE MATERIAL UNDER THE HAUNCH OF THE PIPE.

C. DENSITY FOR THE ABOVE METHODS SHALL BE NO LESS THAN THAT OF THE SURROUNDING GROUND UNLESS OTHERWISE SPECIFIED.

DISPOSAL OF SURPLUS MATERIAL

A. THE CITY MAY AT ITS DISCRETION REQUIRE THAT SURPLUS MATERIAL BE DEPOSITED AT A LOCATION DESIGNATED WITHIN A THREE-MILE RADIUS OF THE WORK SITE.

TYPICAL NOTES - ALL SUBDIVISION CONSTRUCTION DRAWINGS

A. ALL CONSTRUCTION METHODS AND MATERIALS SHALL COMPLY WITH THE CITY ENGINEERING STANDARDS OR ODOT, WHICHEVER IS MORE RESTRICTIVE.

B. ALL COMPACTION SHALL MEET THE CITY REQUIREMENTS. IF TESTING OF COMPACTED AREAS IS REQUESTED BY THE CITY, SAID TESTING SHALL BE PERFORMED AT THE EXPENSE OF THE DEVELOPER.

C. THE CITY WILL LOCATE AREAS UTILIZING PROOFROLLING TECHNIQUES TO DETERMINE NEED OF UNDERCUTTING UNLESS THE DEVELOPER CHOOSES TO HAVE, AT HIS EXPENSE, AN INDEPENDENTLY APPROVED TESTING COMPANY TO DETERMINE UNSUITABLE MATERIAL AREAS THAT NEED UNDERCUTTING. IN PROOFROLLING, IF ANY DEFLECTION IS OBSERVED BY THE CITY INSPECTOR, THE SUBGRADE SHALL BE STABILIZED BY EITHER UNDERCUTTING OR THE USE OF TENSAR OR OTHER APPROVED SOIL STABILIZATION.

D. ALL EMBANKMENT AND SUBGRADE AREAS SHALL BE COMPACTED TO A MINIMUM OF 95% OF ASTM D698 STANDARD PROCTOR CURVE AND TESTED TO REPRESENT A DEPTH OF 12" UNLESS OTHERWISE SPECIFIED BY THE CITY.

E. ALL UNPAVED AREAS WITHIN THE STREET RIGHT-OF-WAY SHALL BE SEEDED WITHIN 48 HOURS AFTER THE CURB IS BACKFILLED. STAKED STRAW BALES MAY BE REQUIRED IN ADDITION TO SEEDING TO CONTROL EROSION IF REQUESTED BY THE CITY.

F. STORM WATER POLLUTION PREVENTION SHOULD BE A HIGH PRIORITY ON ALL CONSTRUCTION PROJECTS. ON ALL PROJECTS WHICH DISTURB AT LEAST 1 ACRES OF SOIL, A NPDES PERMIT IS REQUIRED FROM OEPA AND A COPY OF THE PERMIT MUST BE ON FILE AT THE CITY OFFICE BEFORE CONSTRUCTION BEGINS.

G. THE FINAL LIFT OF ASPHALT CONCRETE SURFACE COURSE IN RESIDENTIAL SUBDIVISIONS IS TO BE PLACED THE FOLLOWING CONSTRUCTION SEASON AFTER THE BASE COURSE IS PLACED, BUT AT LEAST TWO MONTHS PRIOR TO THE EXPIRATION OF THE MAINTENANCE SURETY. THIS MAY NEED TO BE EXTENDED TO ALLOW FOR A TWO MONTH PERIOD.

H. A PUNCH LIST MUST BE REQUESTED WITHIN 30 DAYS AFTER SUBSTANTIAL COMPLETION.

LOW STRENGTH MORTAR BACKFILL

A. IN SITUATIONS WHERE UTILITIES CROSS HEAVILY TRAVELED STREETS OR IT MAY BE DIFFICULT TO GET ADEQUATE COMPACTION ON GRANULAR MATERIAL, LOW STRENGTH MORTAR BACKFILL WILL BE REQUIRED PER ODOT ITEM 613 TYPE 1 ONLY. THE CITY MAY REQUIRE THIS TYPE OF BACKFILL AT THEIR DISCRETION WITH THE COST BEING BORE BY THE CONTRACTOR.

BORING/JACKING

A. MATERIALS.

CASING PIPE SHALL BE WELDED STEEL PIPE CONFORMING TO AWWA C-202. WITH BITUMINOUS OR PETROLEUM COATING.

B. INSTALLATION (CASING PIPE).

1. FURNISH PROCEDURE METHODS TO THE CITY FOR APPROVAL.
2. ALL METHODS AND PROCEDURES SHALL BE APPROVED BY THE CITY PRIOR TO CONSTRUCTION.
3. ADEQUATELY SUPPORT ALL TRENCHES AND BORING/JACKING PITS.
4. INSTALL TO LINE AND GRADE SHOWN.

C. INSTALLATION (CARRIER PIPE).

1. PLACE CONDUITS IN CASING PIPE TO SAME RELATIVE POSITIONS AS ADJACENT DUCT BY USE OF SPACERS.
2. FILL THE SPACE BETWEEN CONDUITS INSIDE THE CASING PIPE WITH CLEAN SAND OR OTHER APPROVED MATERIALS AS APPROVED BY THE CITY.

STEEL CASING PIPE

- A.** STEEL PIPE SHALL HAVE A MINIMUM YIELD STRENGTH OF 35,000 PSI.
- B.** JOINTS BETWEEN THE SECTIONS OF PIPE SHALL BE FULLY WELDED AROUND THE COMPLETE CIRCUMFERENCE OF THE PIPE.
- C.** SIZE—A MINIMUM OF 4" GREATER THAN THE LARGEST OUTSIDE DIAMETER OF THE CARRIER PIPE, EXCLUDING BELL SECTIONS.
- D.** A STEEL CASING PIPE WILL BE REQUIRED FOR STORM SEWER, WATER MAIN, AND SANITARY SEWER. SIZE OF THE CASING PIPE WILL NEED TO BE DESIGNED FOR EACH INDIVIDUAL INCIDENT AND APPROVED BY THE CITY ENGINEER.

WATERMAIN SIZE (INCHES)	DIAMETER NOMINAL (INCHES)	NOMINAL THICKNESS (INCHES)
	10 AND UNDER	0.188
	12 & 14	0.250
8	16	0.281
	18	0.312
12	20 & 22	0.344
16	24	0.375
	26	0.406
	28	0.438
20	30	0.469
	32	0.500
21	34 & 36	0.532
	38	0.562
	40	0.594
	42	0.625
	44 & 46	0.657
	48	0.688
	50	0.719
	52	0.750
	54	0.781
	56 & 58	0.812
	60	0.844
	62	0.875
	64	0.906
	66 & 68	0.938
	70	0.969
	72	1.000

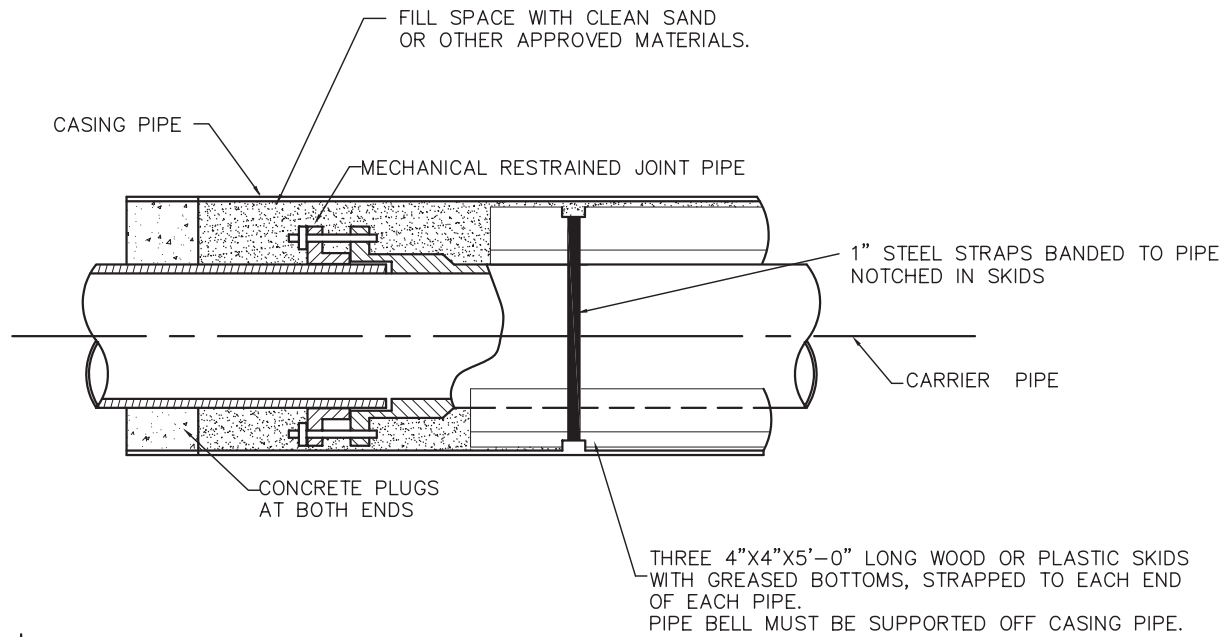

SMOOTH WALL SPIRAL
WELDED STEEL CASING PIPE
ASTM-A-139.

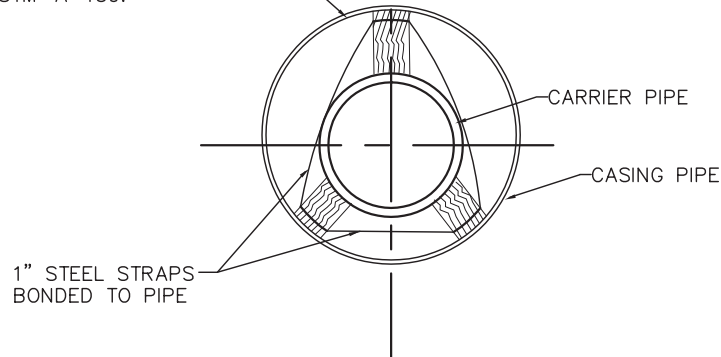

**CITY OF
URBANA**

CASING PIPE DETAIL

REVISIONS:

DATE
APPROVED:
01-13-06
PAGE No.

1167.27

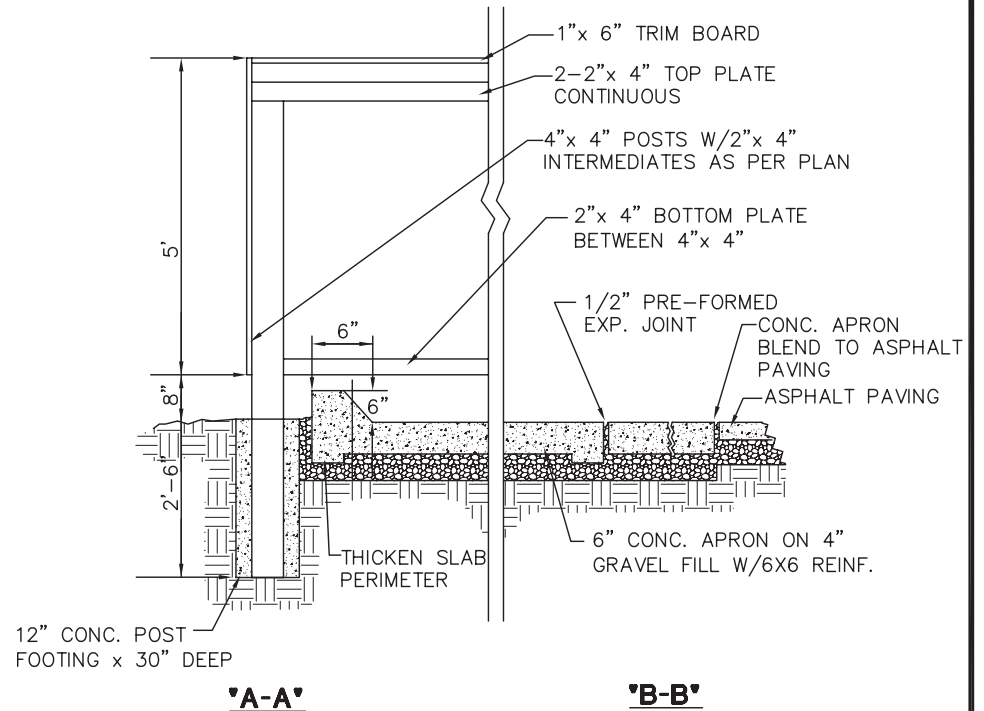
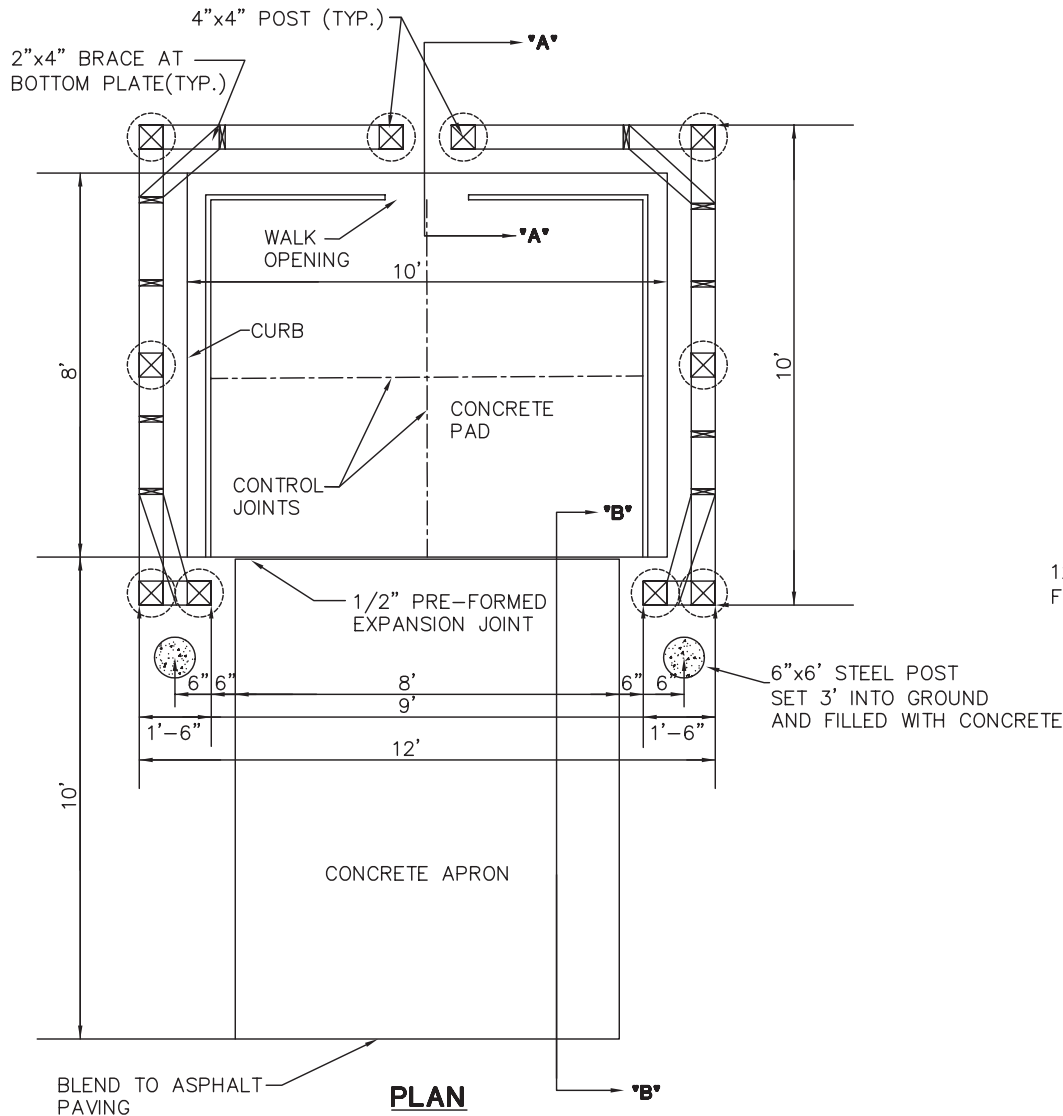

SECTION

TRASH ENCLOSURE

NOTES:

- A.** TRASH CONTAINER TO BE A MAX. OF 2 C.Y. CAPACITY.
- B.** CONTAINER SHALL BE SECURED.
- C.** PLANS TO BE COMPLIED WITH UNLESS OTHERWISE APPROVED.
- D.** ALL DUMPSTERS SHALL BE PROVIDED WITH A DUMPSTER PAD AND A MINIMUM THREE-SIDED 6-FOOT HIGH ENCLOSURE WHICH RESTRICTS THE VIEW OF THE DUMPSTER'S OR DUMPSTERS' CONTAINER ON SITE.
- E.** SEE ZONING CODE FOR PROPER SET BACKS FROM PROPERTY LINE.

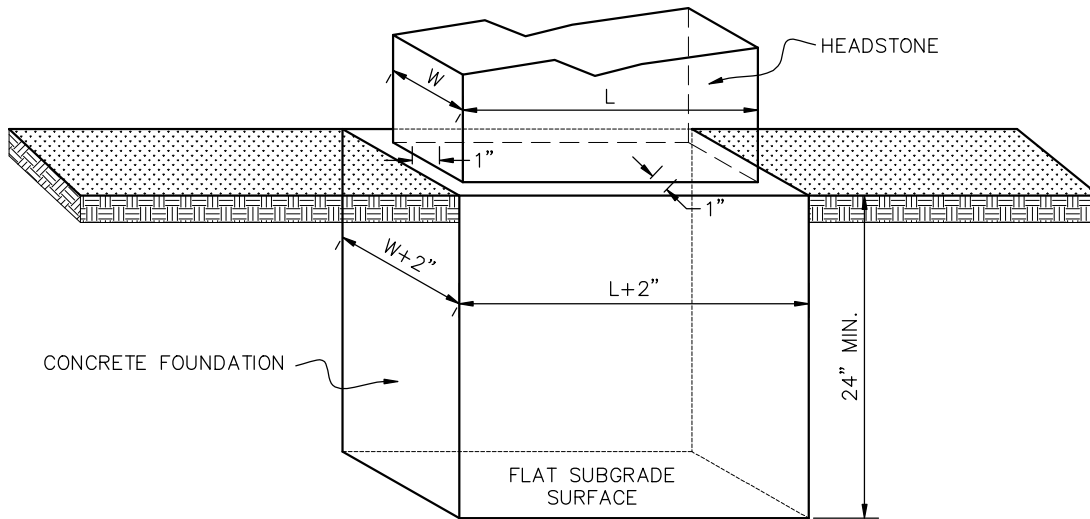

HEADSTONE FOUNDATION NOTES

- A.** CLASS C, NONREINFORCED CONCRETE SHALL BE USED.
- B.** THE DEPTH OF CONCRETE TO BE NO LESS THAN 24". THE LENGTH AND WIDTH OF THE FOUNDATION ARE DETERMINED BY ADDING 2" TO THE HEADSTONE BASE DIMENSIONS.
- C.** THE TOP 4" (MINIMUM) SHALL BE SQUARED, FORMED AND LEVELED.
- D.** THE SUBGRADE SHALL BE LEVELED AND COMPACTED TO PREVENT ROTATION OF THE FOUNDATION.
- E.** ONCE POURED, EXCESS CONCRETE IS TO BE STRUCK OFF THE TOP. A SMOOTH FINISH SHALL BE PROVIDED.

GEOHERMAL CLOSED-LOOP PIPING SYSTEM (GROUND HEAT EXCHANGER)

IN ORDER TO BALANCE THE NEED FOR CLEAN, RENEWABLE ENERGY RESOURCES AND THE NECESSITY TO PROTECT THE PUBLIC HEALTH, SAFETY AND WELFARE OF THE COMMUNITY, THE CITY OF URBANA FINDS THESE REGULATIONS ARE NECESSARY TO ENSURE THAT ALTERNATIVE ENERGY SYSTEMS ARE APPROPRIATELY DESIGNED AND SAFELY SITED AND INSTALLED.

1. ONLY GEOHERMAL CLOSED-LOOP SYSTEMS SHALL BE INSTALLED. A CLOSED-LOOP SYSTEM IS DEFINED AS A PIPE AND HEAT EXCHANGER NETWORK SEALED FROM ITS SURROUNDING ENVIRONMENT. NO OPEN-LOOP SYSTEMS WILL BE PERMITTED. AN OVERALL ISOLATION RADIUS OF 300' AWAY FROM ANY PUBLIC WATER SUPPLY WELLS AND 25' AWAY FROM ANY PRIVATE WATER SUPPLY WELLS SHALL BE MAINTAINED.

2. INSTALLER CERTIFICATION

a) ALL GEOHERMAL SYSTEM INSTALLERS SHALL BE IGSHA (INTERNATIONAL GROUND SOURCE HEAT PUMP ASSOCIATION) CERTIFIED.

3. PIPE MATERIAL AND SIZE REQUIREMENTS

a) POLYETHYLENE:

i. THE MATERIAL SHALL MAINTAIN A 1600 PSI HYDROSTATIC DESIGN BASIS AT 73.4°F PER ASTM D-2837 AND SHALL BE LISTED IN PPI TR4 AS A PE3408 PIPING FORMULATION. THE MATERIAL SHALL BE A HIGH DENSITY, POLYETHYLENE EXTRUSION COMPOUND HAVING A CELL CLASSIFICATION OF PE345434C OR PE355434C WITH A UV STABILIZER OF C, D OR E AS SPECIFIED IN ASTM D-3350 WITH THE FOLLOWING EXCEPTION: THIS MATERIAL SHALL EXHIBIT ZERO FAILURES (FO) WHEN TESTED FOR 192 OR MORE HOURS UNDER ASTM D-1693, CONDITION C, AS REQUIRED IN ASTM D-3350.

ii. PIPE WITH A DIAMETER LESS THAN 1 1/4" (NOMINAL) SHALL BE MANUFACTURED IN ACCORDANCE WITH ASTM D-3035 WITH A DIMENSION RATIO OF 11 (FOR THERMAL AND PERFORMANCE REASONS).

iii. PIPE MANUFACTURED WITH A DIAMETER GREATER THAN 1 1/4" (NOMINAL) AND LARGER SHALL BE MANUFACTURED IN ACCORDANCE WITH ASTM D-3035 (MINIMUM DIMENSION RATIO OF 13.5) OR ASTM D-2447 (SCHEDULE 40). IF THE PIPE IS USED IN A VERTICAL BORE APPLICATION OF OVER 200 FT, IT SHALL BE MANUFACTURED IN ACCORDANCE WITH ASTM D-3035 WITH A DIMENSION RATIO OF 11 (FOR THERMAL AND PERFORMANCE REASONS).

iv. PIPE 3" (NOMINAL) AND LARGER SHALL BE MANUFACTURED IN ACCORDANCE WITH ASTM D-3035, D-2447 OR F-714 WITH A MINIMUM DIMENSION RATIO OF 17.

4. PIPE JOINING METHODS

a) THE ONLY ACCEPTABLE METHOD FOR JOINING BURIED PIPE SYSTEMS IS BY A HEAT FUSION PROCESS. POLYETHYLENE PIPE SHALL BE BUTT OR SOCKET FUSED IN ACCORDANCE WITH PIPE MANUFACTURER'S PROCEDURES.

5. PRESSURE AND FLOW TESTING

a) ALL FUSION JOINTS AND LOOP LENGTHS SHALL BE CHECKED TO VERIFY THAT NO LEAKS HAVE OCCURRED DUE TO FUSION JOINING OR SHIPPING DAMAGE.

b) ALL LOOPS WILL BE PRESSURE TESTED BEFORE INSTALLATION, AND ALL HORIZONTAL COMPONENTS OF THE GROUND HEAT EXCHANGER WILL BE PRESSURE TESTED PRIOR TO BACKFILLING.

c) A MINIMUM VELOCITY OF 2 FT/SEC IN EACH PIPING SECTION MUST BE MAINTAINED FOR A MINIMUM OF 15 MINUTES TO FLUSH THE SYSTEM AND REMOVE ALL AIR. A CHANGE OF MORE THAN ONE INCH IN THE LEVEL OF FLUID IN THE PURGE PUMP TANK DURING PRESSURIZATION INDICATES AIR STILL TRAPPED IN THE SYSTEM. **A WATER PRESSURE OF AT LEAST 100 psi SHALL BE MAINTAINED OVER A 30 MINUTE PERIOD WITH NO OBSERVED LEAKS.**

6. PIPE AND UNIT PLACEMENT

a) THE LOCATION OF ALL UNITS AND PIPING LOOPS SHALL BE A MINIMUM OF FIVE FEET (5') FROM ALL SIDE AND REAR PROPERTY LINES AND BE NO CLOSER TO THE STREET THAN THE FRONT OF THE PRINCIPAL STRUCTURE, UNLESS APPROVED BY THE ENGINEERING DEPARTMENT. NO UNIT OR LOOP SHALL BE LOCATED IN ANY LEGAL EASEMENT.

b) WHITE TRACER WIRE SHALL BE USED ON ALL HORIZONTAL COMPONENTS OF THE SYSTEM WITH LEADS EXITING THE GROUND AT THE BUILDING ABOVE THE SUPPLY AND RETURN LINES.

c) SUPPLY AND RETURN LINES SHALL BE FULLY SLEEVED THROUGH ENTRY AND EXIT POINTS AND ANY BUILDING WALL; SLEEVES SHALL EXTEND AT LEAST 12" BEYOND THE PERIMETER. THERE SHALL BE A 2' MINIMUM SEPARATION BETWEEN SUPPLY/RETURN LINES AND WATER/SEWER LINES.

d) ALL BURIED GEOHERMAL PIPES IN SYSTEMS CONTAINING ANTIFREEZE PASSING PARALLEL WITHIN 5 FEET OF ANY WALL, STRUCTURE OR WATER PIPE SHALL BE INSULATED WITH R2 MINIMUM CLOSED CELL INSULATION.

7. BACKFILLING PROCEDURES

a) BACKFILLING IN HORIZONTAL SECTIONS OF THE PIPING SYSTEM MUST BE DONE ASSURING THE PIPE IS NOT STRESSED BY UNNECESSARY BENDS, NOT IN CONTACT WITH SHARP-EDGED ROCKS AND NOT IN CONTACT WITH ANY LARGE AIR POCKETS. IT IS RECOMMENDED THE LINES REMAIN PRESSURIZED DURING BACKFILLING OPERATIONS TO HELP PRESERVE THE INTEGRITY OF THE PIPES.

b) BACKFILLING IN VERTICAL SECTIONS (BOREHOLES) MUST BE DONE FROM THE BOTTOM UP WITH BENTONITE-BASED GROUT TO ENSURE SURFACE WATER WILL NOT PENETRATE AND CONTAMINATE GROUNDWATER. ASSURE GROUTING MATERIALS AND PROCEDURES MEET THE REQUIREMENTS OF CHAPTER 3701-28 AND 3745-9 OF THE OHIO ADMINISTRATIVE CODE.

8. FLUID COMPOSITION

a) THE FLUID CONTAINED WITHIN THE GEOHERMAL CLOSED-LOOP SYSTEM SHALL USE A BIODEGRADABLE, "FOOD-GRADE" ANTIFREEZE COMPONENT. PROPYLENE GLYCOL OR AN EQUIVALENT SHALL BE USED.

9. MUD CONTAINMENT

a) THE CONTRACTOR SHALL NOT TRACK OR ALLOW MUD TO FLOW ONTO CITY STREETS OR ADJACENT PROPERTIES.

10. RECORDS

a) THE LAYOUT OF THE PIPING NETWORK SHALL BE DIMENSIONED RELATIVE TO A PERMANENT STRUCTURE. A COPY OF THE RECORD SHALL BE PROVIDED TO THE PROPERTY OWNER AND CITY BY THE CONTRACTOR INSTALLING THE GEOHERMAL SYSTEM.

b) FOR VERTICAL LOOP SYSTEMS, SUBMIT ALL BORE LOGS TO ODNR-DSWR.

11. PERMITTING AND INSPECTION

a) A NOMINAL PERMIT FEE WILL BE CHARGED FOR ANY GEOHERMAL INSTALLATION WITHIN THE CITY OF URBANA. THE FEE COVERS AN INITIAL INSPECTION (BEFORE THE LOOP INSTALLATION WHILE THE PRESSURE TESTING IS BEING PERFORMED) AND A FINAL INSPECTION (TO MAKE SURE GROUTING AND BACKFILLING PROCEDURES ARE FOLLOWED) BY THE CITY ENGINEERING DEPARTMENT. THE CONTRACTOR IS RESPONSIBLE FOR MAINTAINING CONTACT WITH THE CITY ENGINEERING DEPARTMENT WHILE THE TESTING AND INSTALLATION IS BEING PERFORMED. TWO WORKING DAYS NOTICE SHALL BE GIVEN PRIOR TO WORK BEGINNING.

ELEVATION, STATION, AND OFFSET
LOCATION FOR CATCH BASIN

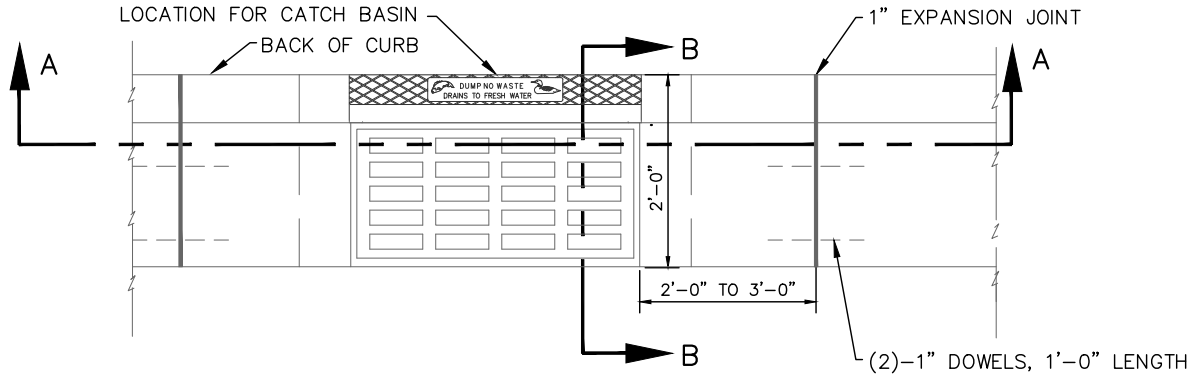

TOP VIEW

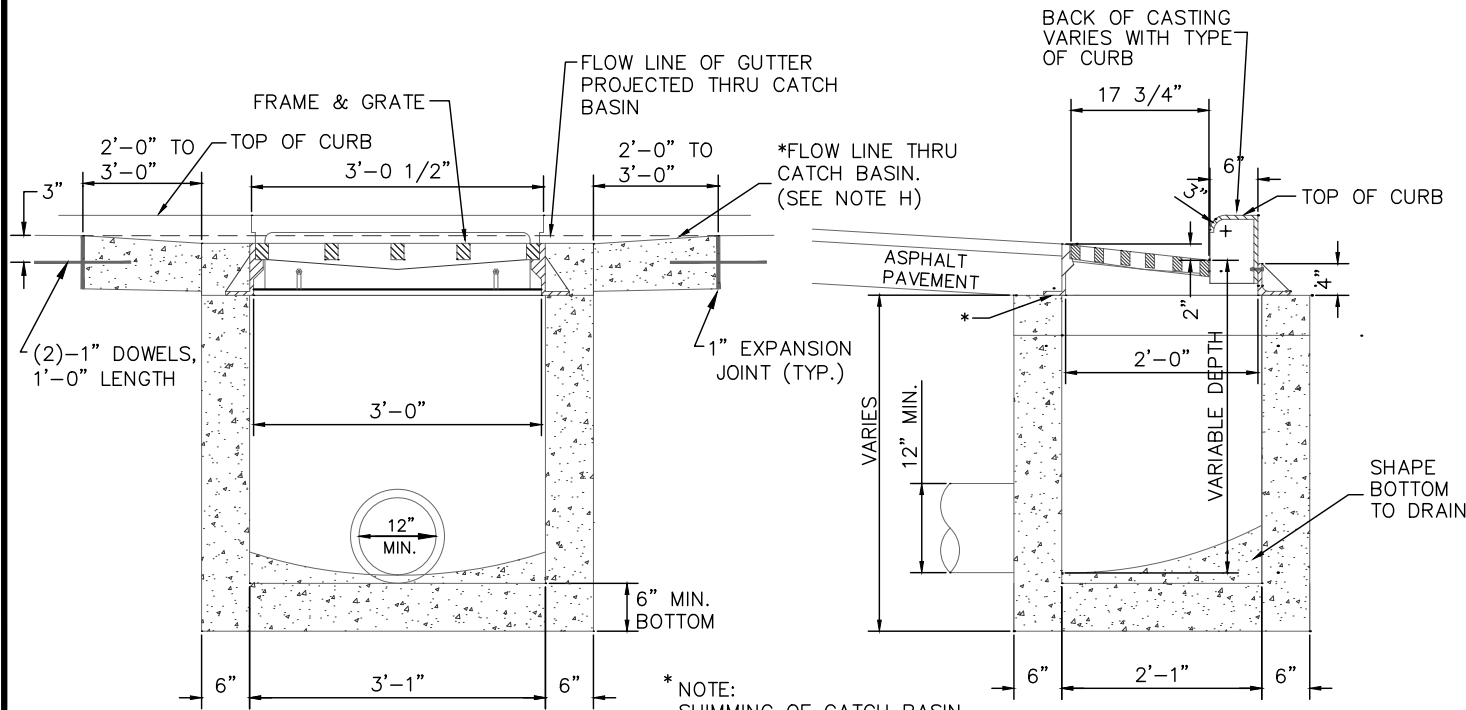

SECTION A-A

SECTION B-B

* NOTE:
SHIMMING OF CATCH BASIN
FRAME MAY BE REQUIRED
TO KEEP LIP OF GUTTER
CONSISTENT.

NOTES

- A.** CASTING SHALL BE EAST JORDAN 7030 OR NEENAH R-3246 OR EQUIVALENT.
- B.** FOR TYPE 2 COMBINATION CURB AND GUTTER THE BACK SHALL BE EAST JORDAN TYPE T4 OR NEENAH (3" RADIUS) (R-3246-178).
- C.** FOR TYPE 1 COMBINATION ROLL CURB AND GUTTER THE BACK SHALL BE EAST JORDAN TYPE T2 OR NEENAH (MOUNTABLE CURB) (R-3246-E).
- D.** CATCH BASIN IN DRIVE APPROACHES TO BE AVOIDED, IF POSSIBLE. THE BACKS SHALL BE EAST JORDAN TYPE T3 OR NEENAH (R-3246-1 WITH CURB PLATE).
- E.** STANDARD GRATE SHALL BE EAST JORDAN TYPE M2, NEENAH TYPE C, OR EQUIVALENT. ALL BAR EDGES TO BE ROUNDED 1/8" RADIUS.
- F.** CONCRETE, CAST-IN-PLACE, TO BE CLASS QC-1. PRECAST CONSTRUCTION PERMITTED AND CONCRETE SHALL MEET THE REQUIREMENTS OF 706.13 WITH 6±2% AIR VOID CONTENT IN THE HARDENED CONCRETE. KNOCKOUTS ARE REQUIRED IN PRECAST CONSTRUCTION. PRECAST WALLS SHALL HAVE A SUFFICIENT AMOUNT OF REINFORCEMENT TO PERMIT SHIPPING AND PLACEMENT WITHOUT DAMAGE.
- G.** CARE SHALL BE TAKEN WHEN CONNECTING TO AN EXISTING CATCH BASIN TO KEEP OPENING AS MINIMAL AS POSSIBLE. IF POSSIBLE, SAW CUT OR USE ROTARY HAMMER FOR OPENING TO MINIMIZE DAMAGE TO CATCH BASIN. PIPE TO INTRUDE INTO CATCH BASIN 1" ONLY AND PIPE MUST BE CUT PARALLEL TO CATCH BASIN. USE NONSHRINK GROUT AROUND PIPE TO SEAL BETWEEN PIPE AND CATCH BASIN.
- H.** DROP FLOW LINE 1/2" WITHIN BLOCK OUT OF COMBINED CURB AND GUTTER WHILE KEEPING LIP OF GUTTER CONSISTENT WITH TOP OF CURB.
- I.** ALL GRATES SHALL BE CONSIDERED "BICYCLE SAFE".
- J.** CAST TOP OF CASTING WITH FISH, DUCK, AND THE WORDING "DUMP NO WASTE DRAINS TO FRESH WATER" OR APPROVED EQUIVALENT.

**CITY OF
URBANA**

TYPE 1 CATCH BASIN

REVISIONS:
01-12-10
04-10-19

DATE
APPROVED:
01-13-06

PAGE No.

1167.31

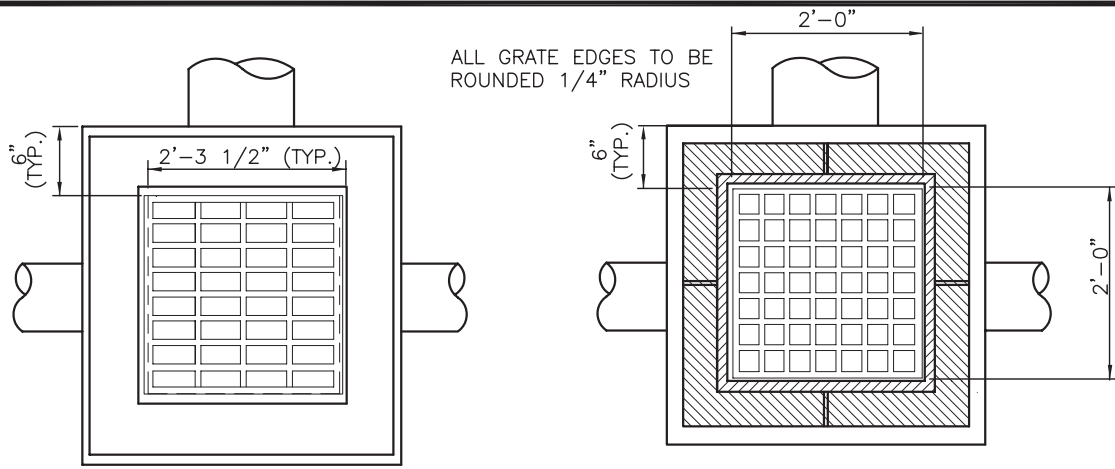

PLAN

PLAN

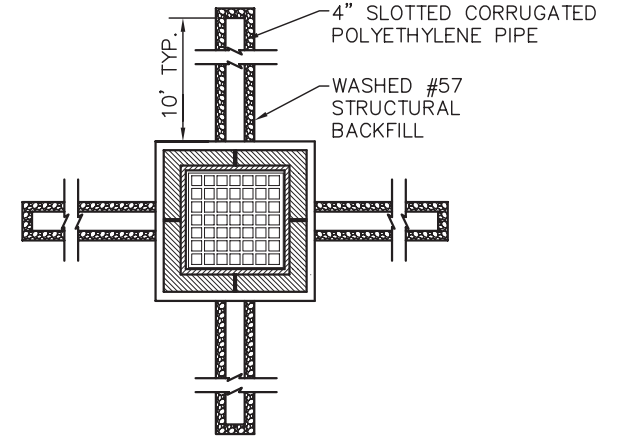

**SUBGRADE DRAINAGE
AROUND CATCH BASIN**

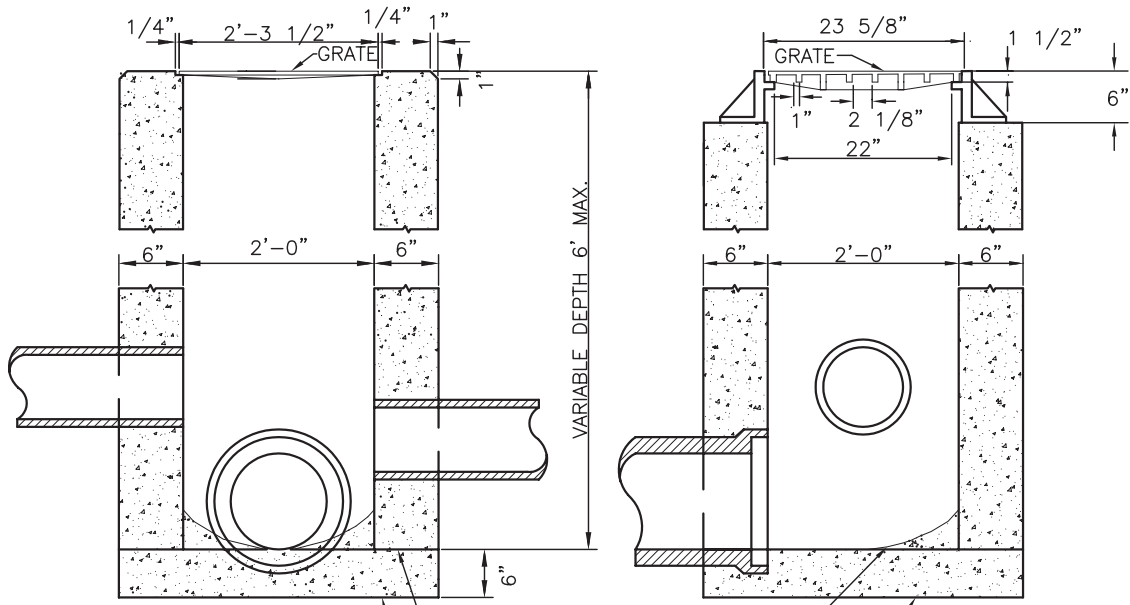

NONPAVED AREAS

PAVED AREAS

BOTTOM SLAB MAY BE CAST SEPARATELY AND THE OUTLET PIPE PLACED ON TOP OF IT WITH THE BOTTOM SHAPED TO DRAIN.

NOTES

- A.** LOCATION AND ELEVATIONS WHEN GIVEN ON THE PLANS IS TOP CENTER OF THE GRATE. WHEN SIDE OPENINGS ARE PROVIDED, ELEVATION SHALL BE THE FLOW LINE OF THE SIDE INLET.
- B.** GRATE FOR NONPAVED AREAS SHALL BE EAST JORDAN IRON WORKS 5110 TYPE M3 OR NEENAH CATALOG NO. R-4859-C OR EQUIVALENT.
- C.** GRATE ELEVATION TO BE PLACED 4" TO 6" BELOW NORMAL DITCH RETURNING TO NORMAL 10' EACH SIDE OF BASIN.
- D.** PRECAST CONSTRUCTION IS REQUIRED, UNLESS OTHERWISE APPROVED, AND CONCRETE SHALL MEET THE REQUIREMENTS OF 706.13 WITH 6±2% AIR VOID CONTENT IN THE HARDENED CONCRETE. KNOCKOUTS SHALL BE PROVIDED IN PRECAST CONSTRUCTION. PRECAST WALLS SHALL HAVE A SUFFICIENT AMOUNT OF REINFORCEMENT TO PERMIT SHIPPING AND PLACEMENT WITHOUT DAMAGE.
- E.** CATCH BASINS NOT PERMITTED IN PAVEMENT AREAS UNLESS USING A FRAME AND GRATE EQUIVALENT OF NEENAH CATALOG NO. R-3405 OR EAST JORDAN IRON WORKS NO. 5250.
- F.** FOR PIPES OVER 18" REFER TO ODOT CATCH BASIN 2-3 AND 2-4. FOR SIDE INLETS REFER TO ODOT CATCH BASIN 2-2-A.
- G.** CARE SHALL BE TAKEN WHEN CONNECTING TO AN EXISTING CATCH BASIN TO KEEP OPENING AS MINIMAL AS POSSIBLE. IF POSSIBLE, SAW CUT OR USE ROTARY HAMMER FOR OPENING TO MINIMIZE DAMAGE TO CATCH BASIN. PIPE TO INTRUDE INTO CATCH BASIN 1" ONLY AND PIPE MUST BE CUT PARALLEL TO CATCH BASIN. USE NONSHRINK GROUT AROUND PIPE TO SEAL BETWEEN PIPE AND CATCH BASIN.

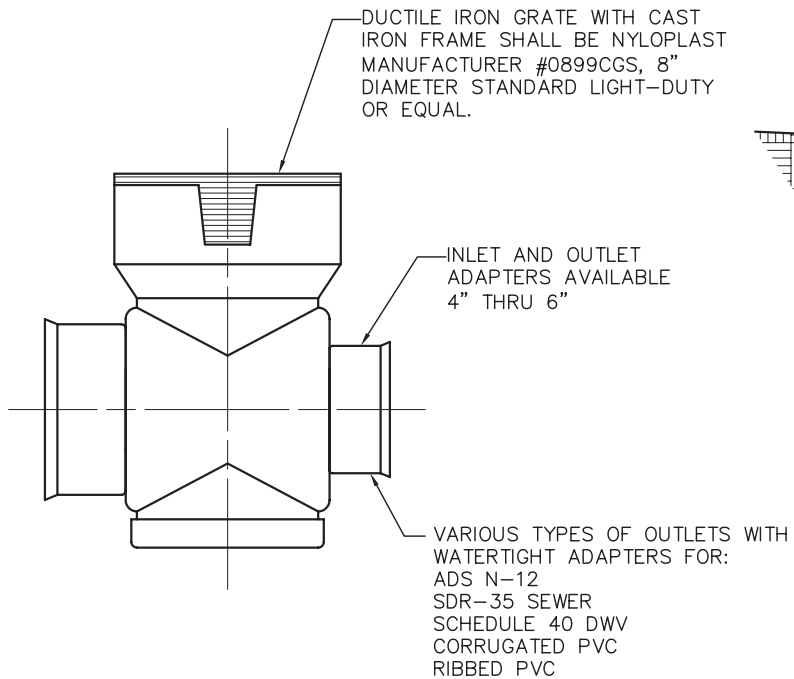

TYPE 2 YARD DRAIN

-STANDARD OR CUSTOM DRAIN BASIN FOR VARIABLE INLET HEIGHT SHALL BE NYLOPLAST MANUFACTURER #2808AG OR EQUAL.

-CONTRACTOR TO INSTALL PER MANUFACTURER'S RECOMMENDATIONS.

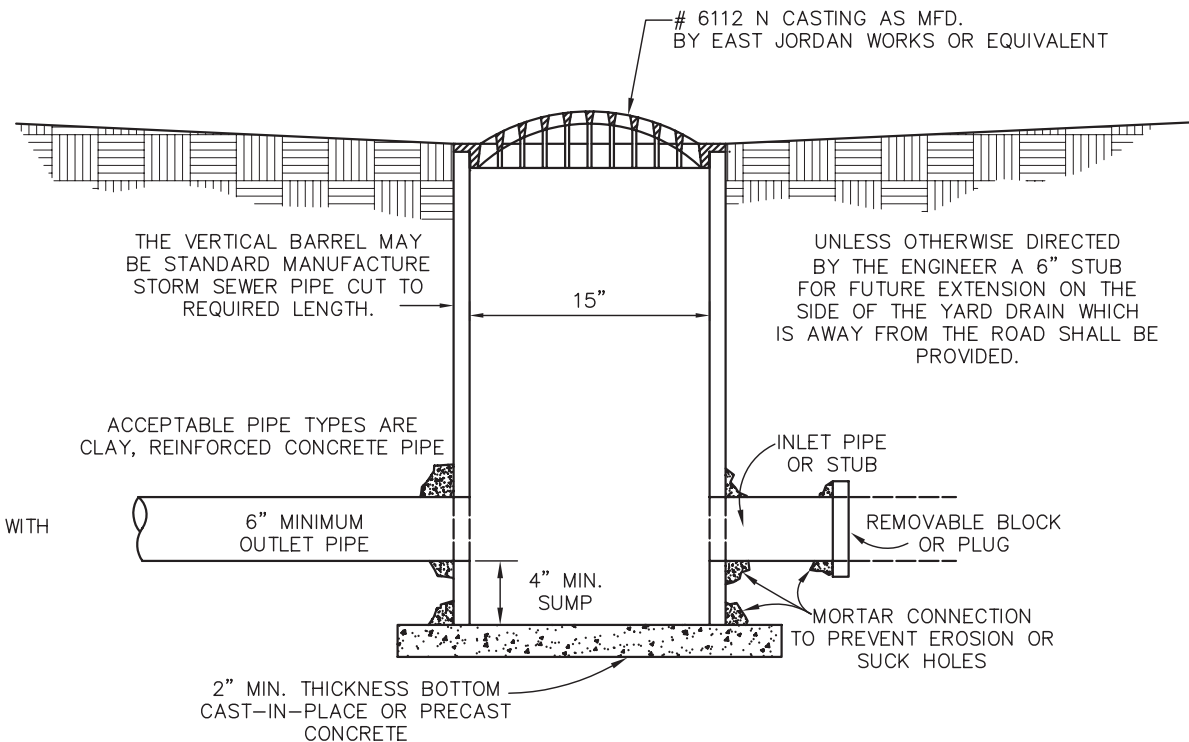

TYPE 3 YARD DRAIN

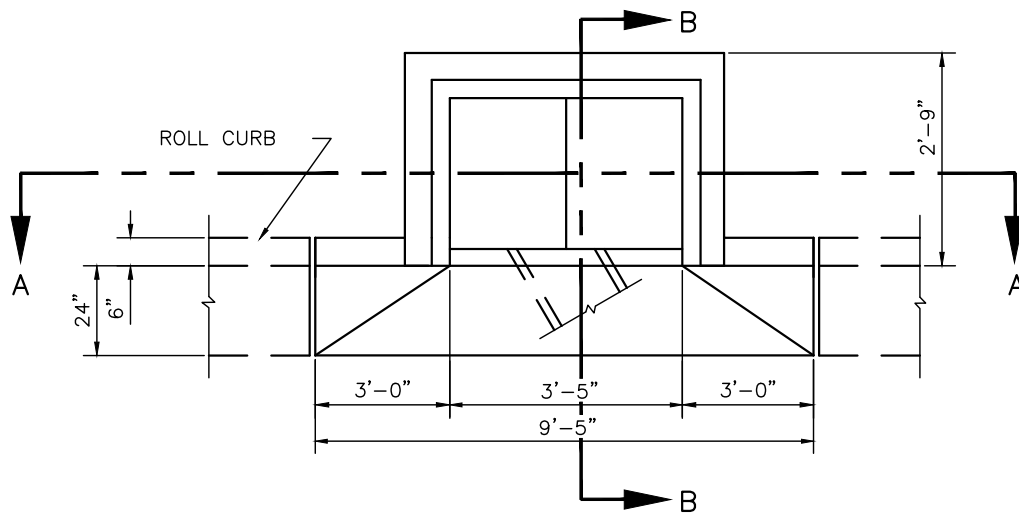

**PLAN
(WITH FRAME AND LID REMOVED)**

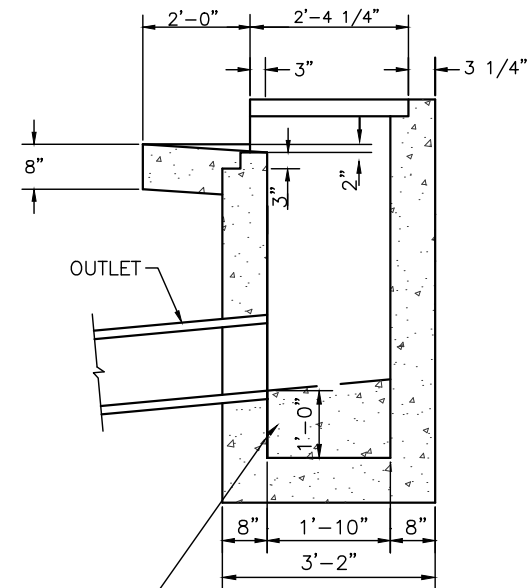

SECTION B-B

NOTES:

- A.** CURBS ALONG APRON TO HAVE VERTICAL FACE AND BE MONOLITHIC WITH APRON.
- B.** FRAME AND LID SHALL BE NEENAH CATALOG No. R-3312-A OR EQUIVALENT.
- C.** CATCH BASIN MAY BE PRECAST UNIT OR POURED IN PLACE.
- D.** PRECAST UNITS SHALL HAVE MINIMUM WALL THICKNESS OF 5".
- E.** PRECAST UNITS SHALL BE DURA-CRETE CB-915-A OR AN APPROVED EQUAL.
- F.** ALL CATCH BASINS SHALL BE PLACED ON A 6" APPROVED AGGREGATE BASE WITH PRECAST BOTTOM.
- G.** BOTTOM TO BE CONTOURED TO PROVIDE POSITIVE DRAINAGE. THE SLOPE TO BE DETERMINED BY THE ENGINEER.
- H.** THE FRONT EDGE OF CATCH BASIN LID FRAME TO BE FLUSH WITH THE EDGE OF ROLL CURB AND FLUSH WITH FACE OF BARRIER CURB.

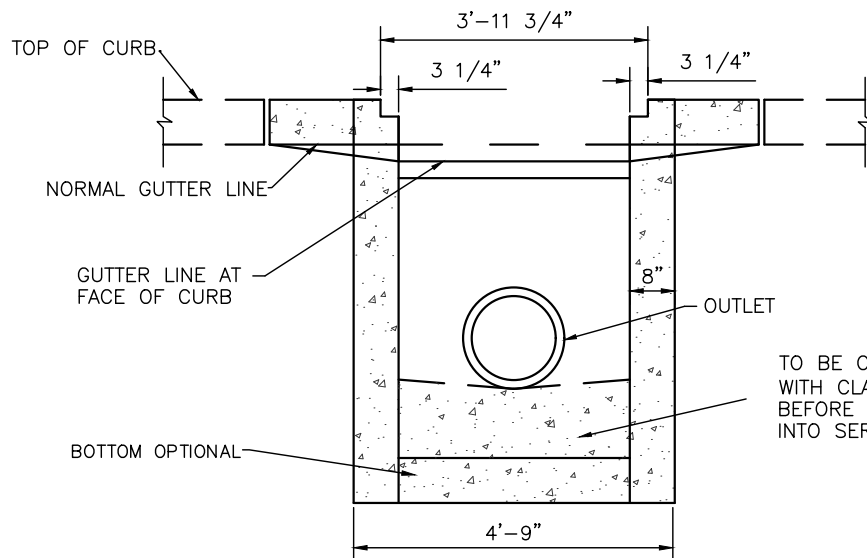

SECTION A-A

TO BE CLEANED AND FILLED WITH CLASS "QC-1" CONCRETE BEFORE CATCH BASIN IS PUT INTO SERVICE.

**CITY OF
URBANA**

**TYPE A CATCH BASIN "IN KIND"
FOR REPAIR/MAINTENANCE ONLY AS DIRECTED BY CITY**

REVISIONS:
04-10-19

DATE
APPROVED:
01-13-06

PAGE No.

1167.34

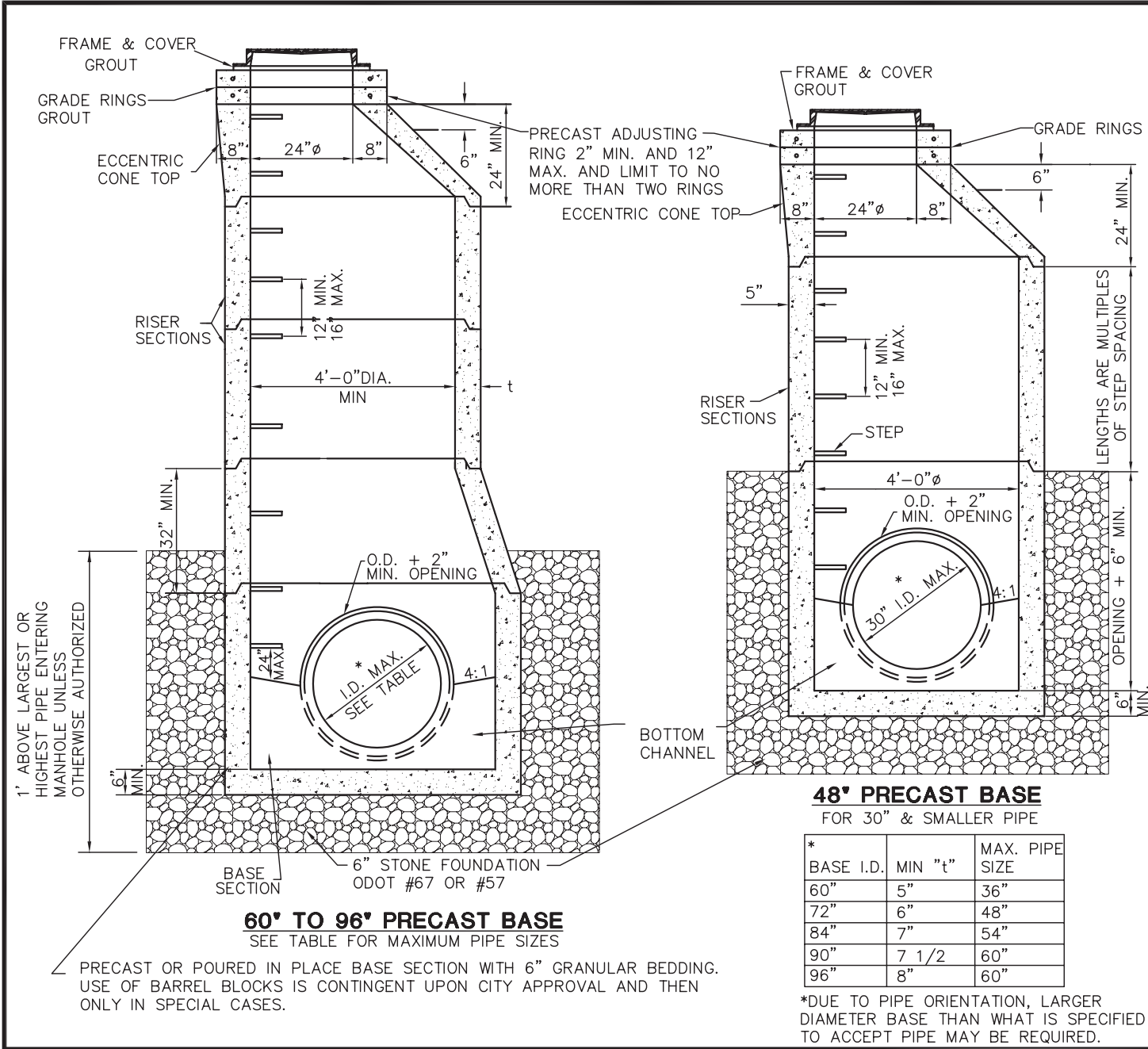

NOTES

- A.** STORM MANHOLE FRAME AND APPROVED VENTED LID SHALL BE EQUAL OF NEENAH NO. R-1767 OR EAST JORDON IRON WORKS NO. 1600.
- B.** TOP AND TRANSITION (OR REDUCER) SECTIONS MAY BE EITHER ECCENTRIC CONE OR FLAT SLAB.
- C.** OPENINGS IN RISER SECTIONS FOR 18" AND SMALLER INLET PIPES MAY BE PREFABRICATED OR CUT IN THE FIELD PROVIDED THE SIDES OF THE PIPE AT THE SPRING LINE DO NOT PROJECT INTO THE MANHOLE.
- D.** MATERIALS FOR BASES AND OTHER PRECAST SECTIONS, INCLUDING REINFORCEMENT SHALL COMPLY WITH ODOT REQUIREMENT OF 706.13 (ASTM C-478).
- E.** LOCATE THE CENTERLINE OF MANHOLE CONES OVER THE CENTERLINE OF THE MAIN SEWER WHENEVER POSSIBLE.
- F.** FOR PIPE SIZES LARGER THAN 60", REFER TO ODOT TYPE 4 TO 5 MANHOLE.
- G.** NO LATERALS MAY PROTRUDE INTO THE INTERNAL MANHOLE.
- H.** MAXIMUM SPACING SHALL BE 400'.
- I.** WHEN CONNECTING TO AN EXISTING STORM MANHOLE CARE SHALL BE TAKEN TO KEEP OPENING AS MINIMAL AS POSSIBLE. IF POSSIBLE, SAW CUT OR USE ROTARY HAMMER FOR OPENING TO MINIMIZE DAMAGE TO STORM MANHOLE AND PIPE MUST BE CUT PARALLEL TO STORM MANHOLE. USE NONSHRINK GROUT AROUND PIPE TO SEAL BETWEEN PIPE AND STORM MANHOLE.
- J.** JOINTS BETWEEN SECTIONS TO BE EITHER MORTAR OR BITUMINOUS PIPE JOINT FILLER (ODOT 706.10)

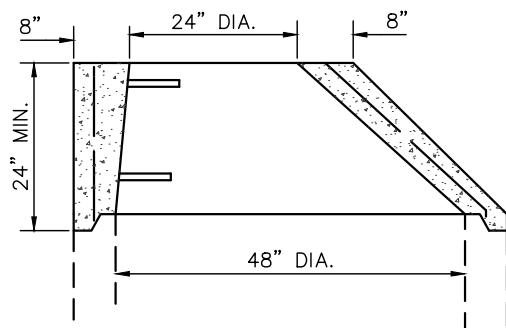

ECCENTRIC CONE TOP

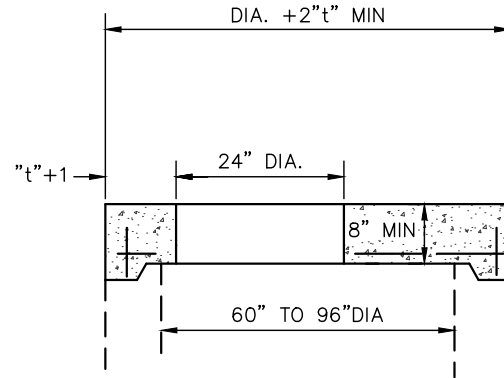

FLAT SLAB TOP

BASE I.D.	MIN "t"	MAX. PIPE SIZE
60"	5"	36"
72"	6"	48"
84"	7"	54"
90"	7 1/2"	60"
96"	8"	60"

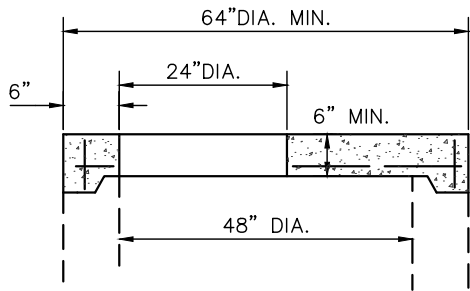

FLAT SLAB TOP

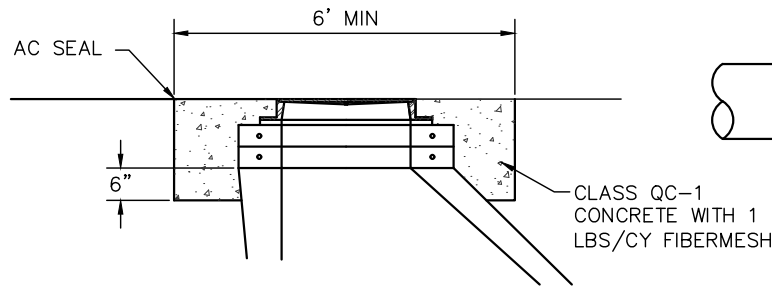

MANHOLE REPAIR CASTING CONSTRUCTION

NOTES:

1. PRECAST CONCRETE ADJUSTING RINGS— ENCASE WITH CONCRETE 6" DOWN FROM BARREL TOP AND UP TO FLUSH WITH THE SURFACE. METAL ADJUSTING RINGS WILL NOT BE ALLOWED.
2. SET MANHOLE, PRECAST CONCRETE ADJUSTING RINGS AND CASTING THEN PAVE OVER MANHOLE. THEN DIG OUT, ENCASE COLLARS AND CASTING AS PER DETAIL WITH CONCRETE TO THE SURFACE.

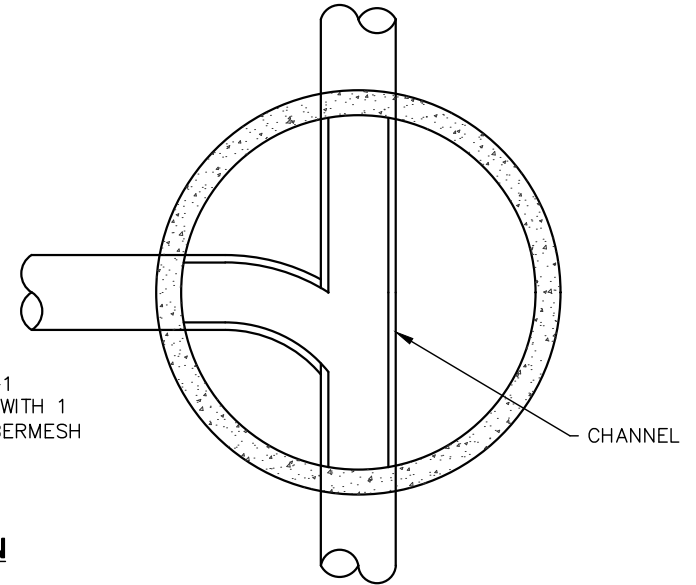

SECTIONAL PLAN

NOTE

ALL INVERTS TO BE CHANNELLED FOR OPTIMUM FLOW.

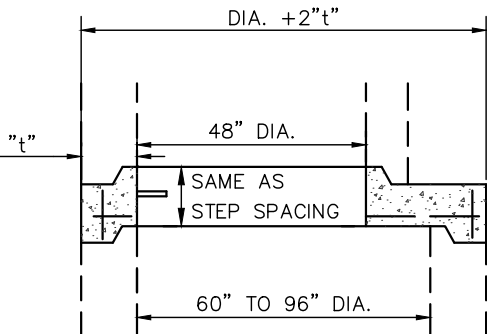

FLAT SLAB TRANSITION

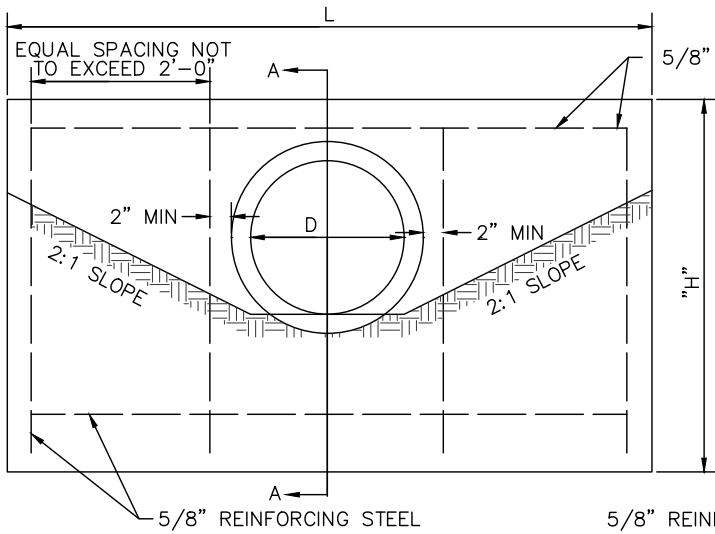

ELEVATION

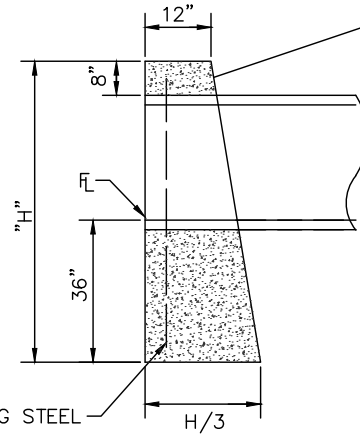

SECTION A-A

NOTES

- A.** THESE FULL HEIGHT HEADWALLS ARE FOR NONSKEWED CULVERTS HAVING A DIAMETER OR RISE OF 36" OR LESS.
- B.** CONCRETE SHALL BE ODOT CLASS QC-1. REINFORCED STEEL BARS SHALL BE 5/8" ROUND.
- C.** DIMENSIONS AND QUANTITIES ARE SHOWN FOR CIRCULAR SECTIONS ONLY. IT WILL BE NECESSARY TO DETERMINE DIMENSIONS FOR THE HW-1 HEADWALL REQUIRED FOR REINFORCED ELLIPTICAL CONCRETE PIPE OR CORRUGATED METAL PIPE ARCHES IN ACCORDANCE WITH THE EQUATIONS LISTED ON THIS DRAWING.
- D.** CHAMFER ALL EXPOSED CORNERS 3/4".
- E.** WHERE THE SOIL BORINGS INDICATE A BEARING CAPACITY OF LESS THAN 2600 LBS. PER SQUARE FOOT, IT WILL BE NECESSARY TO INCREASE THE WIDTH OF THE BASE.
- F.** MINIMUM COVER FOR REINFORCING STEEL SHALL BE 2".
- G.** FOR PIPES HAVING A DIAMETER OR RISE OVER 36", REFERENCE ODOT HW-3 HEADWALLS FOR FULL HEIGHT HEADWALL.
- H.** FOR SKEWED CULVERTS HAVING A DIAMETER OR RISE OF 36" OR LESS, REFERENCE ODOT HW-2 HEADWALLS.
- I.** HEADWALLS MAY BE PRECAST CONCRETE CONSTRUCTED TO THE ABOVE REQUIREMENTS. GROUT AROUND PIPE AFTER INSTALLATION.

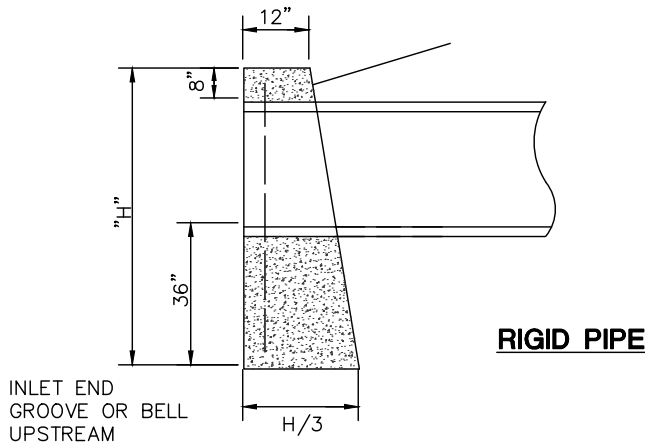

RIGID PIPE

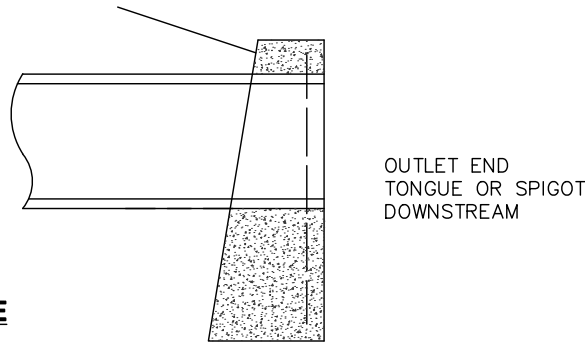

DIMENSIONS			QUANTITIES ONE HEADWALL	
DIAMETER	HEIGHT	LENGTH	CONCRETE C.Y.	REINFORCING STEEL LBS.
15"	5'-2"	7'-0"	1.7	41
18"	5'-5"	8'-4"	2.2	57
21"	5'-8"	9'-8"	2.8	62
24"	5'-11"	11'-0"	3.3	69
30"	6'-5"	13'-8"	4.7	92
36"	7'-0"	16'-4"	6.5	105

- L CIRCULAR SECTIONS = $5D + 4T$
- L ELLIPTICAL OR PIPE-ARCH = $4R + 4T + S$
- H CIRCULAR SECTIONS = $D + T + 44"$
- H ELLIPTICAL OR PIPE-ARCH = $R + T + 44"$
- D = DIAMETER OF PIPE
- R = RISE OF PIPE
- S = SPAN OF PIPE
- T = THICKNESS OF BARREL
- L = LENGTH OF HEADWALL
- H = HEIGHT OF HEADWALL

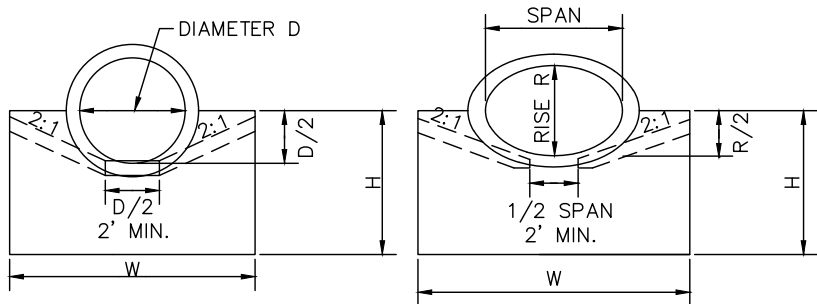

CIRCULAR

ELLIPTICAL

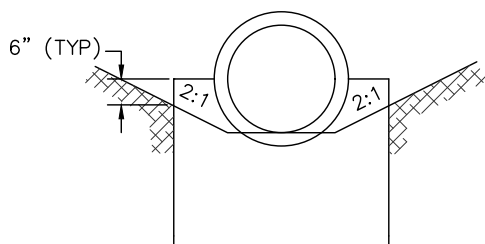

WIDTH OF PROTECTION SHALL EQUAL WIDTH OF HEADWALL. MINIMUM WIDTH 4'-0"

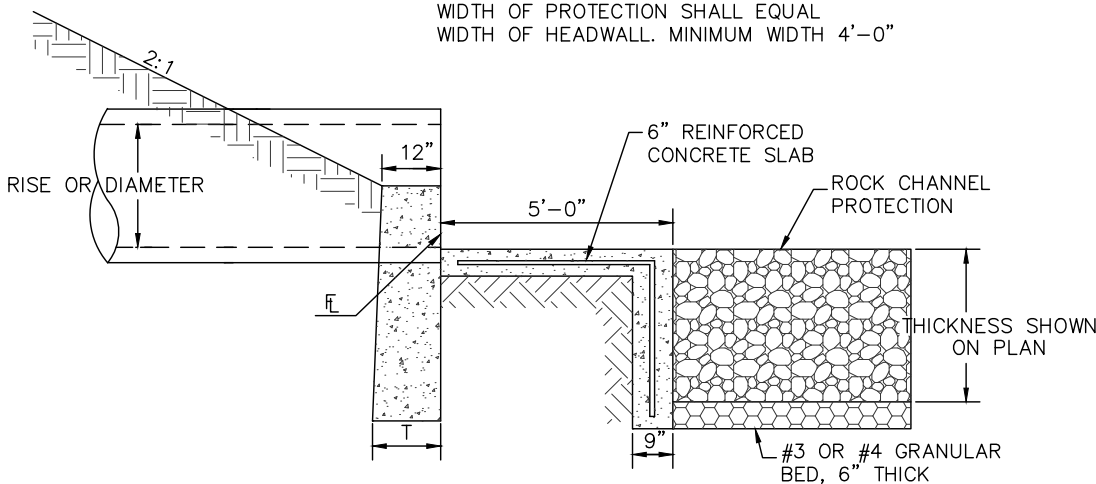

OUTLET CHANNEL PROTECTION DETAIL

(CUTOFF WALL DEPTH 2'-6" MINIMUM IS VARIABLE TO MATCH REQUIRED THICKNESS OF ROCK.)

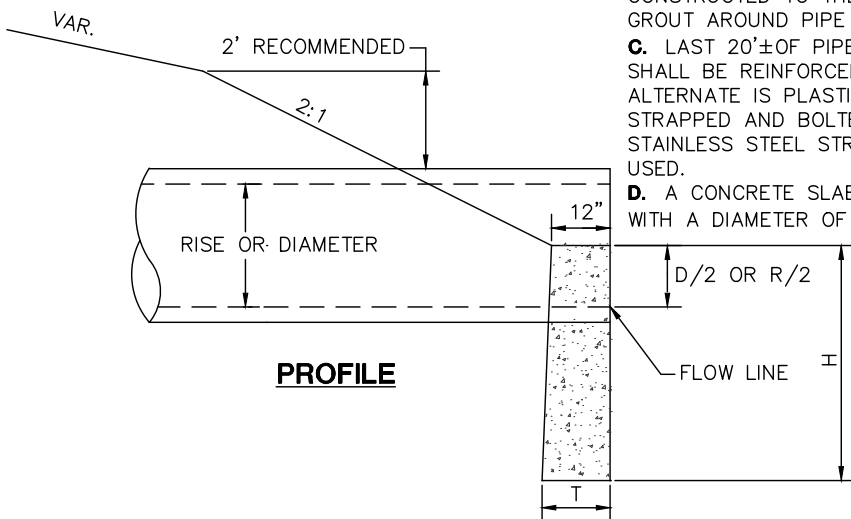

PROFILE

NOTES

- A.** CONCRETE FOR HEADWALLS SHALL BE ODOT CLASS QC-1. CONCRETE QUANTITIES ARE BASED ON HEADWALLS ONLY.
- B.** HEADWALLS MAY BE PRECAST CONCRETE CONSTRUCTED TO THE ABOVE REQUIREMENTS. GROUT AROUND PIPE AFTER INSTALLATION.
- C.** LAST 20'± OF PIPE BEFORE HEADWALL SHALL BE REINFORCED CONCRETE PIPE. AN ALTERNATE IS PLASTIC PIPE THAT IS STRAPPED AND BOLTED TO THE HEADWALL. STAINLESS STEEL STRAP AND BOLTS TO BE USED.
- D.** A CONCRETE SLAB IS REQUIRED FOR PIPES WITH A DIAMETER OF 18" AND ABOVE.

HEADWALL FOR CONCRETE PIPE

CIRCULAR				CONC. C.Y.	ELLIPTICAL					CONC. C.Y.
D	W	H	T		SPAN	RISE	W	H	T	
12"	2'-0"	3'-0"	12"	.20	23"	14"	3'-0"	3'-2"	12"	.29
15"	2'-6"	3'-2"	12"	.25	30"	19"	3'-7"	3'-4"	12"	.35
18"	3'-0"	3'-3"	12"	.31	34"	22"	3'-11"	3'-5"	12"	.38
21"	3'-6"	3'-4"	12"	.37	38"	24"	4'-6"	3'-6"	12"	.44
24"	4'-0"	3'-6"	12"	.43	42"	27"	4'-8"	3'-7"	12"	.45
27"	4'-6"	3'-8"	12"	.49	45"	29"	5'-2"	3'-8"	12"	.49
30"	5'-0"	3'-9"	12"	.56	49"	32"	5'-5"	3'-10"	12"	.52
33"	5'-6"	3'-10"	12"	.62	53"	34"	5'-11"	4'-0"	14"	.66
36"	6'-0"	4'-0"	12"	.69	60"	38"	6'-10"	4'-2"	14"	.82
39"	6'-6"	4'-2"	12"	.77	68"	43"	8'-0"	4'-4"	16"	1.01
42"	7'-0"	4'-3"	12"	.84	76"	48"	9'-2"	5'-0"	16"	1.34
48"	8'-0"	4'-6"	14"	1.09	83"	53"	10'-4"	5'-2"	18"	1.65
54"	9'-3"	4'-9"	14"	1.32	91"	58"	11'-6"	5'-5"	18"	1.97
60"	10'-6"	5'-6"	16"	1.93	98"	63"	12'-7"	5'-7"	20"	2.38
66"	11'-9"	5'-9"	18"	2.42	106"	68"	13'-9"	5'-10"	20"	2.69
72"	13'-0"	6'-0"	18"	2.77	113"	72"	14'-9"	6'-0"	22"	3.14
78"	14'-3"	6'-3"	20"	3.37	121"	77"	15'-11"	6'-3"	22"	3.49
84"	15'-6"	6'-6"	22"	4.05	128"	82"	17'-0"	6'-5"	24"	4.04

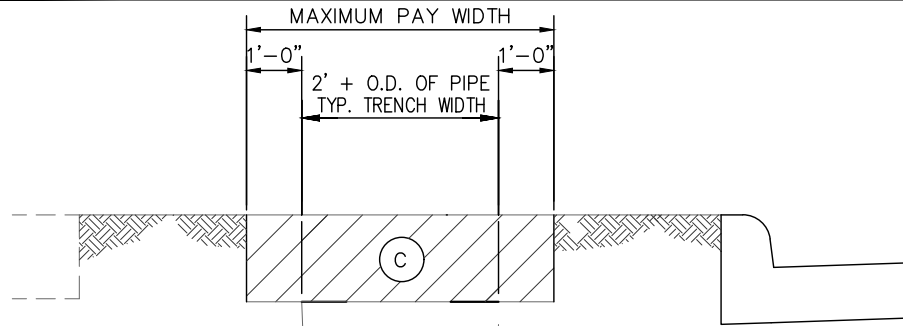

NOTE:
 MAXIMUM PAY LIMITS,
 ANY PAVEMENT
 REPAIR BEYOND THE
 MAXIMUM PAY LIMITS
 WILL BE THE
 RESPONSIBILITY OF
 THE CONTRACTOR.

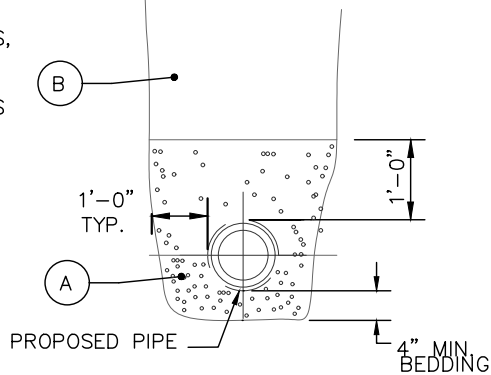

TRENCH DETAIL NOTES

A. STRUCTURAL BEDDING SHALL BE WASHED GRAVEL, ODOT 703 #8, #57, OR #67, OR OTHER APPROVED EQUIVALENT.

B. ALL TRENCHES WITHIN 5' OF PROPOSED OR EXISTING PAVEMENT, WALK, CURB AND GUTTER, DRIVES, ALLEYS, STONE AREAS, OR OTHER HARD SURFACE SHALL BE BACKFILLED WITH ODOT 703 WASHED GRAVEL TO WITHIN 12" OF SURFACE (#8, #57, OR #67).

ALL TRENCHES BEYOND 5' OCCURRING IN SEED AREAS ARE TO BE BACKFILLED WITH NATIVE FILL TO WITHIN 6" OF SURFACE. NATIVE FILL IS TO BE COMPACTED TO 98% OF ASTM D698 STANDARD PROCTOR CURVE.

C. OFF-PAVEMENT AREAS SHALL BE PROVIDED WITH A MINIMUM OF 6" OF TOPSOIL OVER THE COMPACTED MATERIAL AND THEN SEEDED AND MULCHED PER ODOT ITEM 659.

STREET AREAS SHALL FOLLOW TYPICAL SECTION 1167.20. GRAVEL DRIVE AREAS SHALL BE 12" OF 304 STABILIZED CRUSHED AGGREGATE. ASPHALT DRIVES SHALL BE REPAIRED WITH A MINIMUM OF 4" OF 448 SURFACE ASPHALT ON 8" OF 304 STABILIZED CRUSHED AGGREGATE. CONCRETE DRIVE AREAS SHALL BE 6" OF 452 PLAIN CONCRETE ON 6" OF 304 STABILIZED CRUSHED AGGREGATE.

D. THE OPEN ENDS OF ALL PIPES SHALL BE PLUGGED TO THE APPROVAL OF THE CITY BEFORE LEAVING THE WORK FOR THE NIGHT.

E. COMPACTED 304 IS TO BE USED UNDER CURB AND GUTTER AND SIDEWALKS WHERE DISTURBED BY CONSTRUCTION.

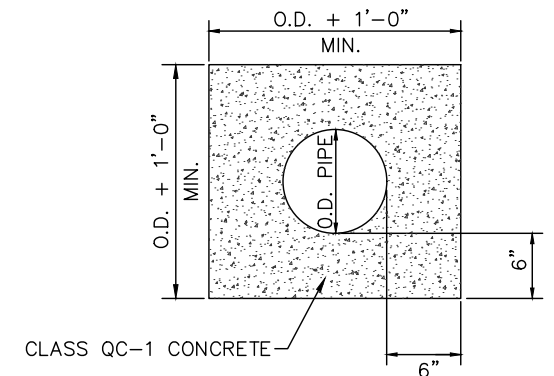

CONCRETE ENCASEMENT DETAIL

**CITY OF
 URBANA**

STORM SEWER TRENCH DETAILS

REVISIONS:
 07-02-09
 12-20-12
 04-10-19

DATE
 APPROVED:
 01-13-06

PAGE No.

1167.39

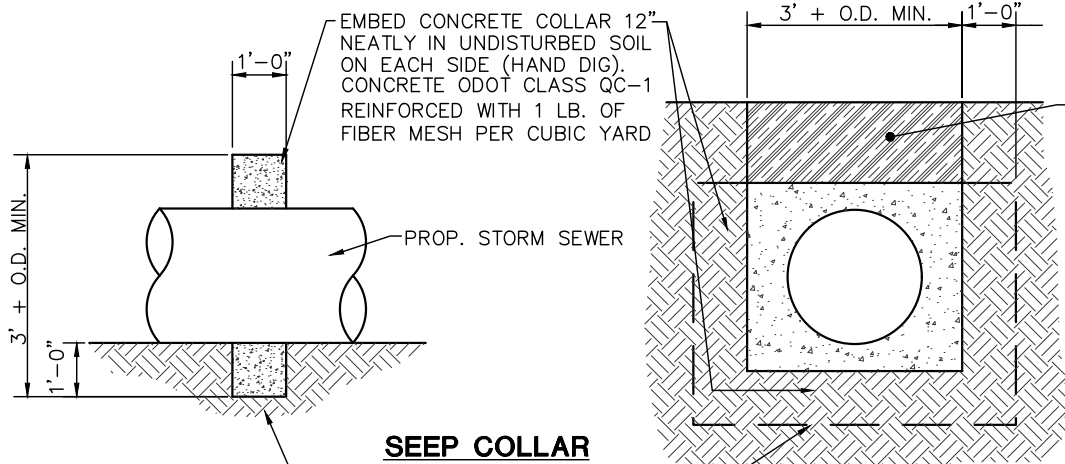

EMBED CONCRETE COLLAR 12" NEATLY IN UNDISTURBED SOIL ON EACH SIDE (HAND DIG). CONCRETE ODOT CLASS QC-1 REINFORCED WITH 1 LB. OF FIBER MESH PER CUBIC YARD

SEEP COLLAR

POUR BOTTOM OF COLLAR NEAT IN 12" OF EMBANKMENT CLAY. FOR PIPES 18" AND OVER

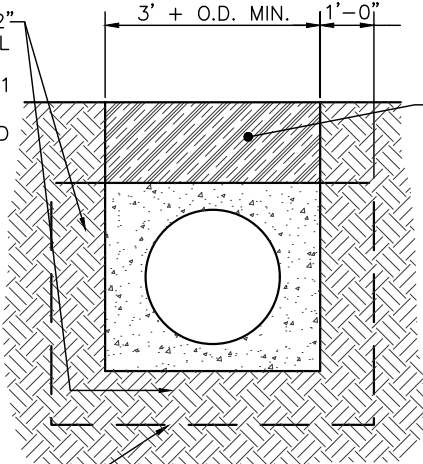

COMPACTED CLAY BACKFILL. BACKFILL OPERATIONS SHALL BE PERFORMED BY HAND TAMPING

DETENTION BASIN OUTLET

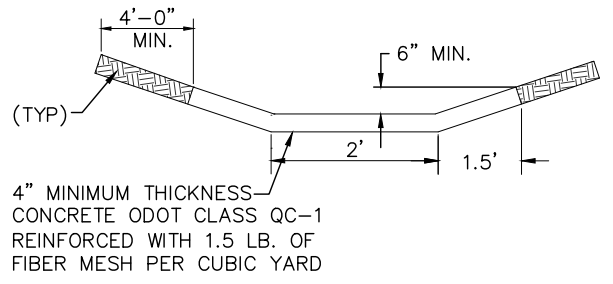

PAVED CONCRETE CHANNEL DETAIL

NOTES

- A.** ALL DETENTION BASINS WITH SLOPES LESS THAN 1% REQUIRE CONCRETE CHANNEL.
- B.** DIFFERENT SHAPE OR SIZE OF CONCRETE CHANNEL MAY BE REQUIRED DEPENDING ON DESIGN, AS APPROVED BY THE CITY ENGINEER.
- C.** ALL WORK SHALL BE DONE IN ACCORDANCE WITH CITY SPECIFICATIONS.
- D.** BOTTOM OF DRAINAGE DITCH SHALL BE FORMED BEFORE PLACING CONCRETE. ALL FORMS SHALL BE SET TO GRADE AND ALIGNMENT AND BE INSPECTED AND APPROVED BY THE CITY BEFORE POURING CONCRETE.
- E.** RIP RAP SHALL BE USED ON EMERGENCY OVERFLOWS WHEN THE VELOCITY OF WATER WILL SCOUR THE SOIL, OR AS REQUIRED BY ENGINEER.

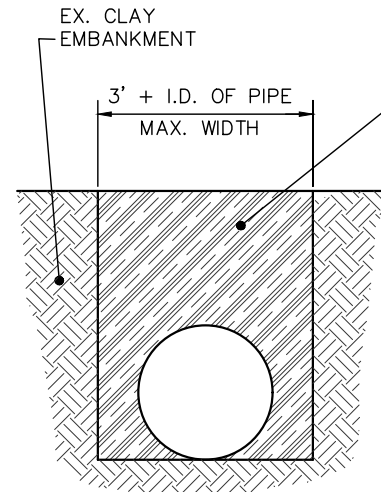

NOTES

- A.** EXTRA COMPACTION AND CARE SHALL BE TAKEN TO ENSURE WATER SEALING OF DIKE AND PROPER CLAY BEDDING OF PIPE.
- B.** COMPACTION REQUIREMENTS SHALL BE 95% STANDARD MAXIMUM DRY WEIGHT DENSITY.
- C.** THIS SHALL BE REQUIRED AT ALL PIPES ENTERING OR EXITING THE DETENTION BASIN.
- D.** PAYMENT FOR THESE ITEMS SHALL BE INCIDENTAL TO ITEM 603.

CLAY TRENCH DETAIL THROUGH DETENTION BASIN

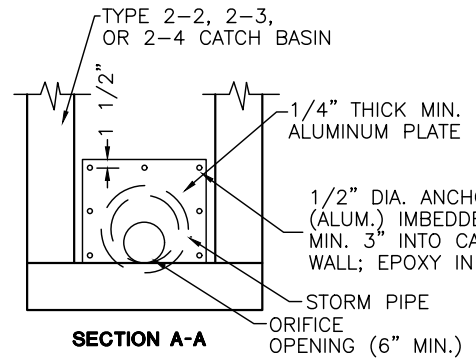

SECTION A-A

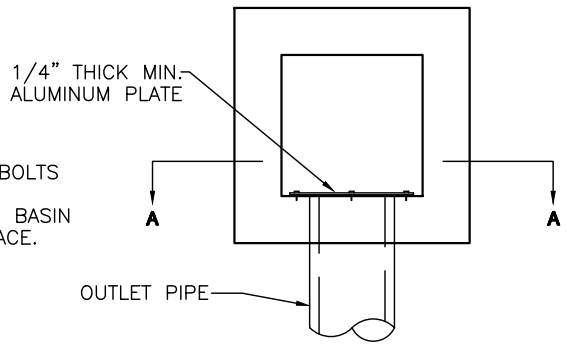

PLAN VIEW

DETENTION/RETENTION OUTLET ORIFICE

NOTES

A. NO WORK SHALL BE APPROVED OR ACCEPTED BY THE CITY UNLESS 2 WORKING DAYS NOTICE OF COMMENCING WORK IS GIVEN TO THE CITY.

B. ALL TEMPORARY PAVEMENT AND SIDEWALK SHALL BE MAINTAINED BY THE CONTRACTOR OR THE DEVELOPER AT HIS OWN EXPENSE IN A SUITABLE AND SAFE CONDITION FOR TRAFFIC UNTIL PERMANENT REPLACEMENT IS MADE OR THE PROJECT IS FINALLY ACCEPTED BY THE CITY.

C. ALL STORM SEWER CONSTRUCTION SHALL ADHERE TO ODOT SPECIFICATIONS LATEST REVISION OR WITH THE CITY STORM SEWER SPECIFICATIONS, WHICHEVER IS APPLICABLE AND MORE RESTRICTIVE.

D. MASTIC MATERIAL IS REQUIRED ON ALL NON O-RING STORM SEWER AND MANHOLES, UNLESS OTHERWISE APPROVED.

E. WHEN A CASTING IS REMOVED IT REMAINS CITY PROPERTY AND IS TO BE DELIVERED TO THE CITY GARAGE, UNLESS OTHERWISE APPROVED.

F. ANY DETAILS OR NOTES NOT DIRECTLY ADDRESSED IN THESE ENGINEERING STANDARDS SHALL BE COORDINATED WITH THE CITY ENGINEERING DEPARTMENT.

G. ALL STORM SEWER SHALL BE INSTALLED USING A PIPE LASER, INSIDE THE PIPE IF POSSIBLE, FOR GRADE AND ALIGNMENT.

UTILITY STAKING

A. OFFSET AND GRADE AT EACH MANHOLE, CATCH BASIN, AND OTHER STRUCTURES. OFFSET AND GRADE 50' AND 100' OUT FROM EACH MANHOLE UNLESS OTHERWISE APPROVED.

PIPE

A. ALL STORM SEWER PIPE SHALL HAVE A MINIMUM DIAMETER OF 12", UNLESS OTHERWISE APPROVED.

B. TYPES OF PIPE PERMITTED

REINFORCED CONCRETE PIPE
REINFORCED CONCRETE ELLIPTICAL PIPE
CORRUGATED POLYETHYLENE SMOOTH-LINED PIPE
POLYVINYL CHLORIDE CORRUGATED SMOOTH-INTERIOR PIPE
POLYVINYL CHLORIDE PROFILE WALL PIPE
POLYVINYL CHLORIDE SOLID WALL PIPE
POLYPROPYLENE CORRUGATED DOUBLE WALL PIPE
POLYPROPYLENE TRIPLE WALL PIPE

ODOT MATERIALS NUMBER

706.02
706.04
707.33
707.42
707.43
707.45
707.65
707.69

EXISTING TILE HOOKUPS

A. THE DRAINAGE TILE CURRENTLY CONNECTED TO THE EXISTING STORM SEWER SHALL BE CONNECTED TO THE PROPOSED STORM SEWER. ANY DRAINAGE TILE DAMAGED BY THE CONTRACTOR SHALL BE REPLACED BY THE CONTRACTOR TO A CONDITION EQUAL TO OR BETTER THAN ITS ORIGINAL CONDITION. ANYTHING REMOVED, REPLACED, AND/OR CONNECTED TO THE STORM SEWER SHALL BE NOTED ON THE AS-BUILT DRAWINGS AND SHALL BE INSPECTED BY THE INSPECTOR BEFORE THEY ARE COVERED.

B. ALL FIELD OR STORM DRAINS WHICH ARE ENCOUNTERED DURING CONSTRUCTION SHALL BE PROVIDED WITH UNOBSTRUCTED OUTLETS OR PLUGGED AS APPROVED AND DIRECTED BY THE CITY.

NOTES

A. TEMPORARY EROSION AND SEDIMENT CONTROL MEASURES SHALL BE PROVIDED FOR ALL CONSTRUCTION PROJECTS HAVING SIGNIFICANT GRADING. THE CONTROLS ARE PROVIDED DURING CONSTRUCTION TO PREVENT SOIL ERODED FROM THE CONSTRUCTION AREA FROM ENTERING ADJACENT WATERWAYS AND PROPERTIES.

B. CONSTRUCTION ITEMS INCLUDE SEDIMENT BASINS, SEDIMENT DAMS, DIVERSION DIKES AND/OR DITCHES AND STRAW BALES OR OTHER FILTER DIKES SHOWN ON ODOT STANDARD DRAWING MC-11. OTHER MISCELLANEOUS EROSION CONTROL MEASURES INCLUDE REPAIR SEEDING AND MULCHING, COMMERCIAL FERTILIZER, WATER AND MOWING AND ROCK CHANNEL PROTECTION, COVERED IN ODOT SPECIFICATION ITEMS 659 AND 601.

C. THE SIZE OF THE ENTIRE DRAINAGE AREA CONTRIBUTING FLOW IS USED TO DETERMINE THE MOST EFFECTIVE EROSION CONTROL METHOD. IN MANY CASES, THE MAJOR PORTION OF THE CONTRIBUTING AREA WILL BE BEYOND THE PROJECT LIMITS, AND FOR THOSE CASES IT WILL BE NECESSARY TO CONTROL THE FLOW FROM OUTSIDE BEFORE IT REACHES THE AREA DISTURBED BY PROJECT CONSTRUCTION. FLOW FROM THE AREA DISTURBED BY CONSTRUCTION SHALL BE TREATED PRIOR TO COMBINING IT WITH OFF-PAVEMENT DRAINAGE.

D. EROSION AND SEDIMENT CONTROL MEASURES SHALL BE PROVIDED FOR ALL SUBDIVISIONS AND INDIVIDUAL SITES UNLESS OTHERWISE APPROVED. THE CONTROL MEASURES ARE TO BE PROVIDED DURING CONSTRUCTION TO PREVENT EROSION FROM ENTERING ADJACENT WATERWAYS AND PROPERTIES.

E. THERE SHALL BE ONLY ONE CONSTRUCTION ENTRANCE OFF THE SITE, ENTRANCE TO BE CONSTRUCTED OF 8" OF #2 STONE, 75' LONG BY 20' WIDE. CONTRACTOR TO KEEP MUD OFF EXISTING STREETS, NO EQUIPMENT TO BE PARKED ON EXISTING STREETS. MORE THAN ONE ENTRANCE MUST BE APPROVED BY THE CITY.

PLAN SUBMITTAL

A. ALL SITE PLANS SHALL INCLUDE APPROPRIATE EROSION AND SEDIMENT CONTROL DEVICES AND SHALL BE SUBMITTED TO THE CITY FOR APPROVAL PRIOR TO COMMENCEMENT OF ANY WORK UNLESS OTHERWISE APPROVED. ALL PROJECTS WHICH DISTURB 5 ACRES OR MORE MUST HAVE OEPA EROSION CONTROL APPROVALS.

CONSTRUCTION

A. ALL EROSION AND SEDIMENT CONTROL DEVICES MUST BE INSPECTED AND APPROVED BY THE CITY UNLESS OTHERWISE APPROVED.

STORM WATER PERMITS

A. ON ALL PROJECTS WHICH DISTURB AT LEAST 1 ACRE OF SOIL, A NPDES PERMIT IS REQUIRED FROM OEPA AND A COPY OF THE PERMIT MUST BE ON FILE AT THE CITY BEFORE CONSTRUCTION BEGINS.

B. EROSION CONTROL SUBMITTALS SHALL BE AS PER THE CURRENT STORM WATER MANAGEMENT ORDINANCE.

CONTROL MEASURES

A. DISTURB ONLY THE AREAS NEEDED FOR CONSTRUCTION.

B. REMOVE ONLY THOSE TREES, SHRUBS, AND GRASSES THAT MUST BE REMOVED FOR CONSTRUCTION; PROTECT THE REST TO PRESERVE THEIR AESTHETIC AND EROSION-CONTROL VALUES.

C. INSTALL SEDIMENT BASINS AND DIVERSION DIKES BEFORE DISTURBING THE LAND THAT DRAINS INTO THEM.

D. INSTALL EROSION AND SEDIMENT CONTROL PRACTICES AS INDICATED IN THE PLAN. THE PRACTICES ARE TO BE MAINTAINED IN EFFECTIVE WORKING CONDITION DURING CONSTRUCTION AND UNTIL THE DRAINAGE AREAS HAVE BEEN PERMANENTLY STABILIZED.

E. TEMPORARILY STABILIZE EACH SEGMENT, GRADED OR OTHERWISE DISTURBED LAND, INCLUDING THE SEDIMENT-CONTROL DEVICES NOT OTHERWISE STABILIZED, BY SEEDING AND MULCHING OR BY MULCHING ALONE. AS CONSTRUCTION IS COMPLETED, PERMANENTLY STABILIZE EACH SEGMENT WITH PERENNIAL VEGETATION AND STRUCTURAL MEASURES.

F. LEVEL DIVERSION DIKES, SEDIMENT BASINS, AND SILT TRAPS AFTER AREAS THAT DRAIN INTO THEM ARE STABILIZED. ESTABLISH PERMANENT VEGETATION ON THESE AREAS. SEDIMENT BASINS THAT ARE TO BE RETAINED FOR STORM WATER DETENTION MAY BE SEEDED TO PERMANENT VEGETATION AFTER THEY ARE BUILT.

G. DISCHARGE WATER FROM OUTLET STRUCTURES AT NON-EROSIVE VELOCITIES.

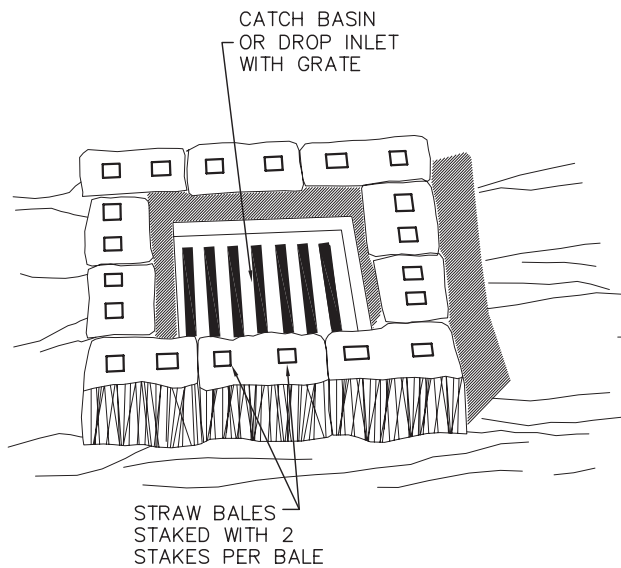

BALE INLET FILTER

NOTES

A. THIS METHOD OF INLET PROTECTION IS APPLICABLE WHERE THE INLET DRAINS A RELATIVELY FLAT AREA (SLOPES NO GREATER THAN 5%) WHERE SHEET OR OVERLAND FLOWS (NOT EXCEEDING 0.5 CFS) ARE TYPICAL.

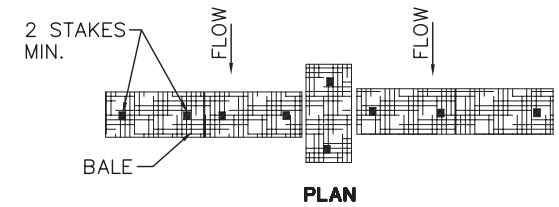
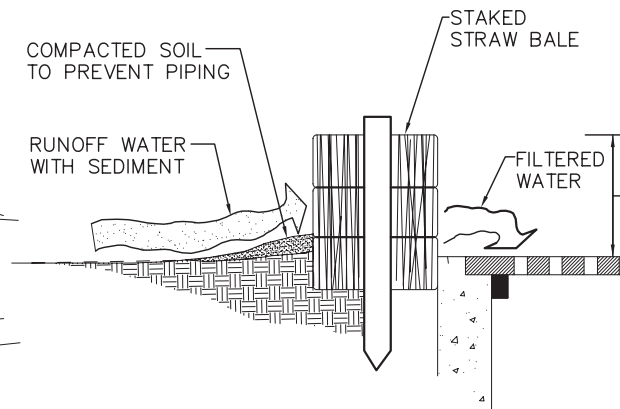

PLAN

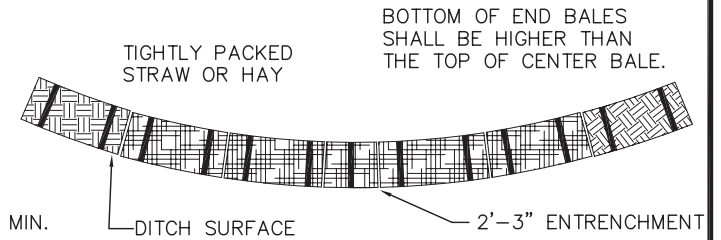

ELEVATION

BALE DITCH CHECK

NOTES

A. PLACEMENT OF BALES SHALL BE TIGHTLY PLACED, ADJACENTLY, AND ENTRENCHED 2" AND 3" BEFORE STAKING AND A SMALL AMOUNT OF LOOSE SOIL SHALL BE LIGHTLY COMPACTED ALONG THE UPSTREAM EDGE OF THE BALES OR SEE ODOT STANDARD CONSTRUCTION DRAWING MC-11.

B. EACH BALE SHALL BE FIRMLY STAKED WITH A MINIMUM OF 2 STAKES AT LEAST 3' IN LENGTH. STAKE SHALL BE WOODEN 2" X 2", REINFORCING BARS OR FENCE POST, AS APPROVED BY THE CITY.

C. LOOSE STRAW OR HAY SHALL BE SCATTERED FOR A DISTANCE OF 10' ON THE UPSTREAM SIDE OF EACH DITCH CHECK, AND SHALL BE WEDGED BETWEEN AND UNDER STAKED BALES.

A. SET STAKES NO MORE THAN 3' APART AND DRIVE THEM INTO THE GROUND AT LEAST 8".

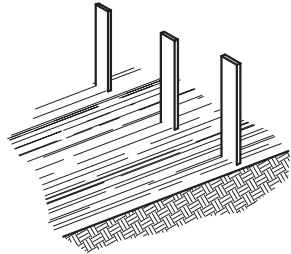

B. EXCAVATE A 4" x 4" TRENCH UP SLOPE ALONG THE LINE OF STAKES.

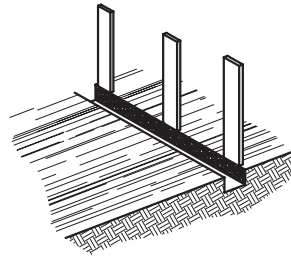

C. STAPLE FILTER MATERIAL ON UP SLOPE SIDE OF STAKES AND EXTEND IT INTO THE TRENCH. WHEN JOINTS ARE NECESSARY, OVERLAP MATERIAL BETWEEN 2 STAKES AND FASTEN SECURELY.

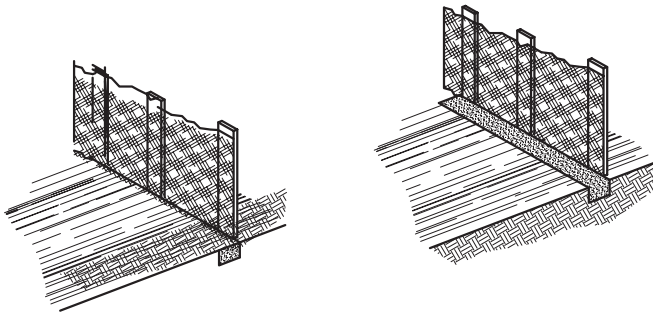

D. BACKFILL AND COMPACT THE EXCAVATED SOIL.



SILT FENCE

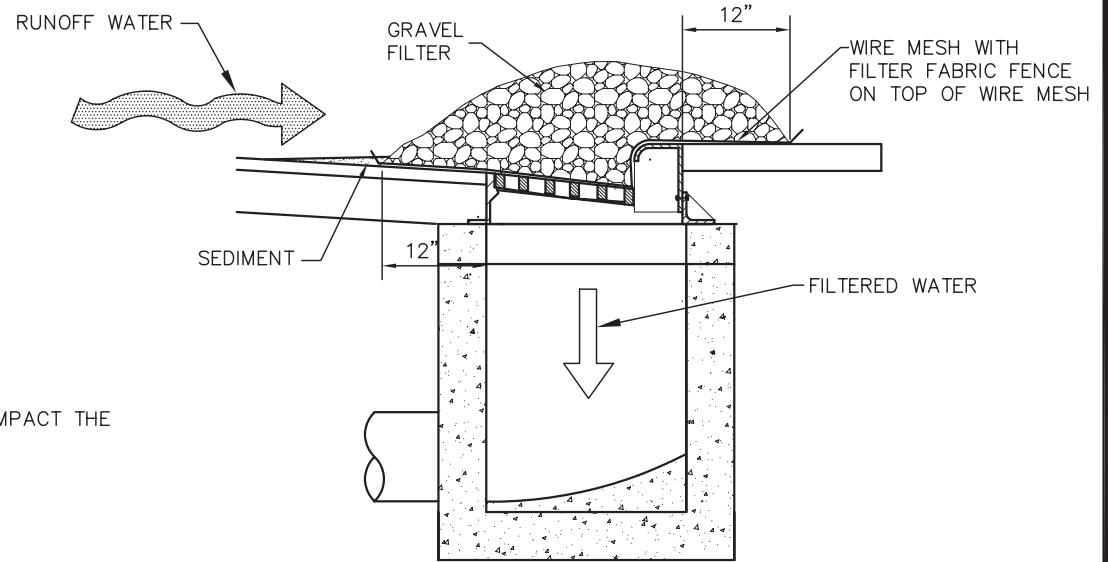

GRAVEL CURB INLET SEDIMENT FILTER (AS REQUIRED BY THE CITY)

GRAVEL CURB INLET SEDIMENT FILTER NOTES

- A.** HARDWARE CLOTH OR COMPARABLE WIRE MESH WITH 1/2-INCH OPENINGS SHALL BE PLACED OVER THE CURB INLET OPENING SO THAT AT LEAST 12 INCHES OF WIRE EXTENDS ACROSS THE INLET COVER AND AT LEAST 12 INCHES OF WIRE EXTENDS ACROSS THE CONCRETE GUTTER FROM THE INLET OPENING, AS ILLUSTRATED.
- B.** STONE SHALL BE PILED AGAINST THE WIRE SO AS TO ANCHOR IT AGAINST THE GUTTER AND INLET COVER AND TO COVER THE INLET OPENING COMPLETELY. ODOT NO. 1 COARSE AGGREGATE SHALL BE USED.
- C.** IF THE STONE FILTER BECOMES CLOGGED WITH SEDIMENT SO THAT IT NO LONGER PERFORMS ITS FUNCTION, THE STONE MUST BE PULLED AWAY FROM THE CATCH BASIN, CLEANED AND REPLACED.

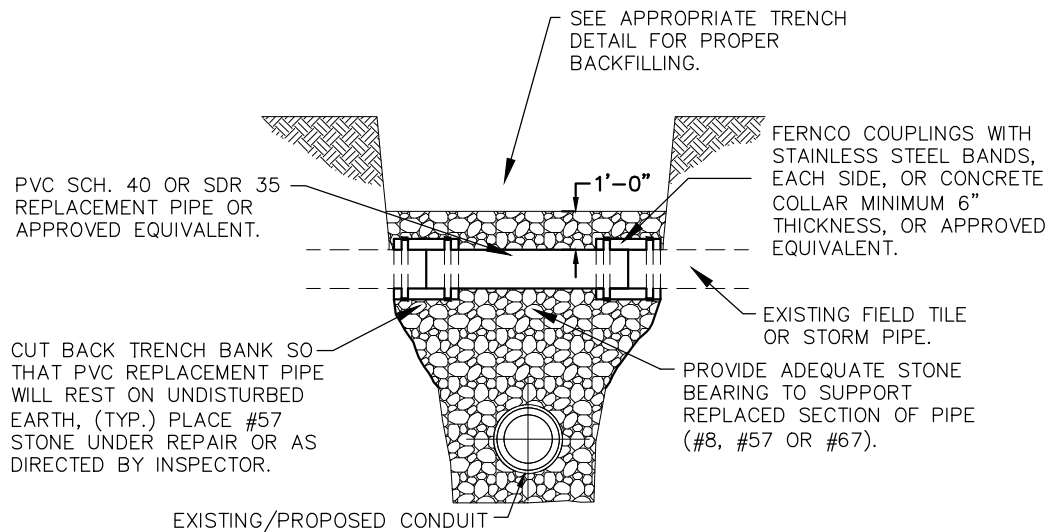

REPAIR OF EXISTING FIELD TILE OR STORM PIPE DETAIL

**CITY OF
URBANA**

REPAIR OF EXISTING FIELD TILE OR STORM PIPE DETAIL

REVISIONS:
12-20-12

DATE
APPROVED:
01-13-06

PAGE No.

1167.45

HYDRANT PUMP NOZZLE
4-1/2" I.D.
NATIONAL STANDARD THREADS

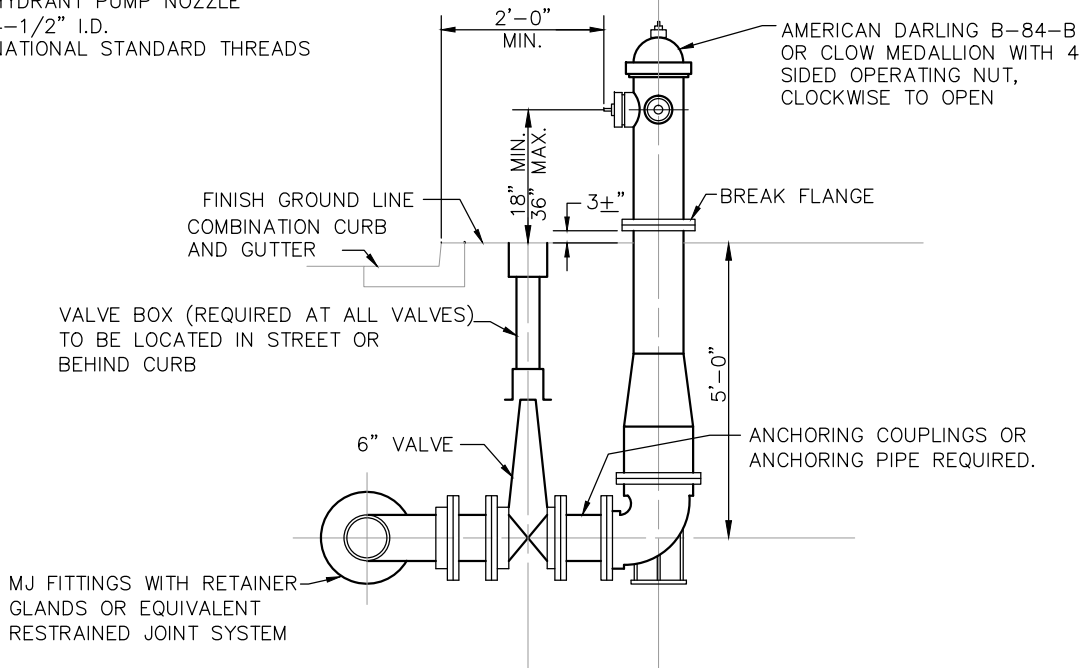

SECTION VIEW

AMERICAN DARLING B-84-B
OR CLOW MEDALLION WITH 4
SIDED OPERATING NUT,
CLOCKWISE TO OPEN

6" MJ ANCHORING
COUPLING OR ANCHORING
PIPE (TYP)

6" WATER VALVE

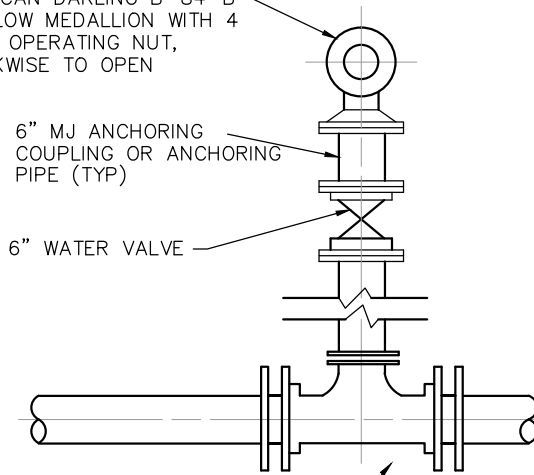

ANCHORING TEE WITH 6" BRANCH

BASIC TEE DETAIL PLAN

NOTES

- A.** FIRE HYDRANTS - AMERICAN DARLING B-84-B, CLOW MEDALLION, OR APPROVED EQUAL; MECHANICAL JOINT; TWO 2-1/2" HOSE NOZZLE WITH NATIONAL STANDARD THREAD CONNECTIONS; ONE 4"-1/2" PUMPER NOZZLE WITH NATIONAL STANDARD THREADS; CONFORMING TO AWWA C-502; CW TO OPEN; BREAK FLANGES 3" ABOVE GRADE. HYDRANT SHALL BE YELLOW IN COLOR WITH 4-SIDED, SQUARE OPERATING NUT (7/8" TOP AND 1" BOTTOM DIMENSION). HYDRANT MUST BE SELF DRAINING.
- B.** GATE VALVES SHALL BE AWWA C-509, RESILIENT WEDGE, NONRISING STEM, MECHANICAL JOINT, 150 PSI WORKING PRESSURE, CW TO OPEN WITH ARROW INDICATING OPEN DIRECTION, MUELLER OR EQUIVALENT.
- C.** VALVE BOXES SHALL BE 2-PIECE, ADJUSTABLE 36" TO 48", 6" DIAMETER NOMINAL, ADJUSTABLE SCREW TYPE, COVER MARKED "WATER", DOMESTIC MADE ONLY.
- D.** ALL FITTINGS TO BE RESTRAINED.
- E.** ALL FITTINGS TO BE AWWA C-153 DUCTILE IRON, COMPACT.
- F.** ALL VALVES AND HYDRANTS SHALL OPEN RIGHT BY TURNING IN A CLOCKWISE DIRECTION.
- G.** CONTRACTOR TO FACE HYDRANT AS REQUIRED BY THE CITY.
- H.** THE LAYING OF PIPE ON EXISTING DIRT WITH THE BELLS CUT OUT SHALL NOT BE PERMITTED.
- I.** THE OPEN ENDS OF ALL PIPES AND SPECIAL CASTINGS SHALL BE PLUGGED OR OTHERWISE CLOSED WITH A WATERTIGHT PLUG TO THE APPROVAL OF THE CITY BEFORE LEAVING THE WORK FOR THE NIGHT.
- J.** A MINIMUM OF 4" WASHED STONE BACKFILL SHALL BE PLACED AS HYDRANT IS INSTALLED.

ANCHORING TEE WITH
6" BRANCH

WATER MAIN

PUMPER NOZZLE
TO FACE
PAVEMENT WHEN
PLACED IN SERVICE
TO BE BAGGED
IF OUT OF SERVICE

VALVE

HYDRANT

6" MJ ANCHORING COUPLING

6" MJ ANCHORING ELBOW

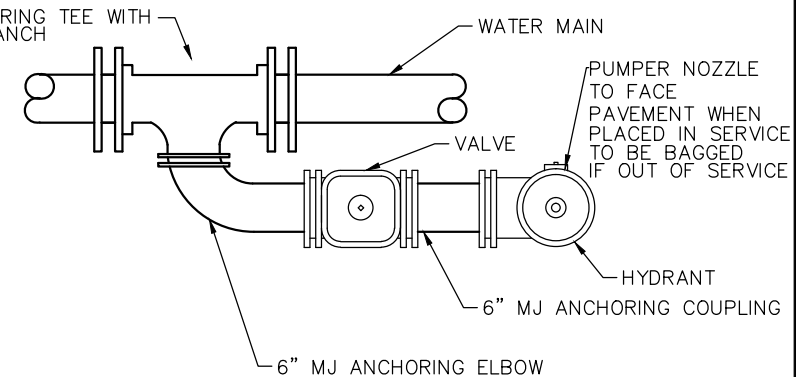

**SPECIAL MECHANICAL JOINT
HYDRANT TEE DETAIL PLAN**

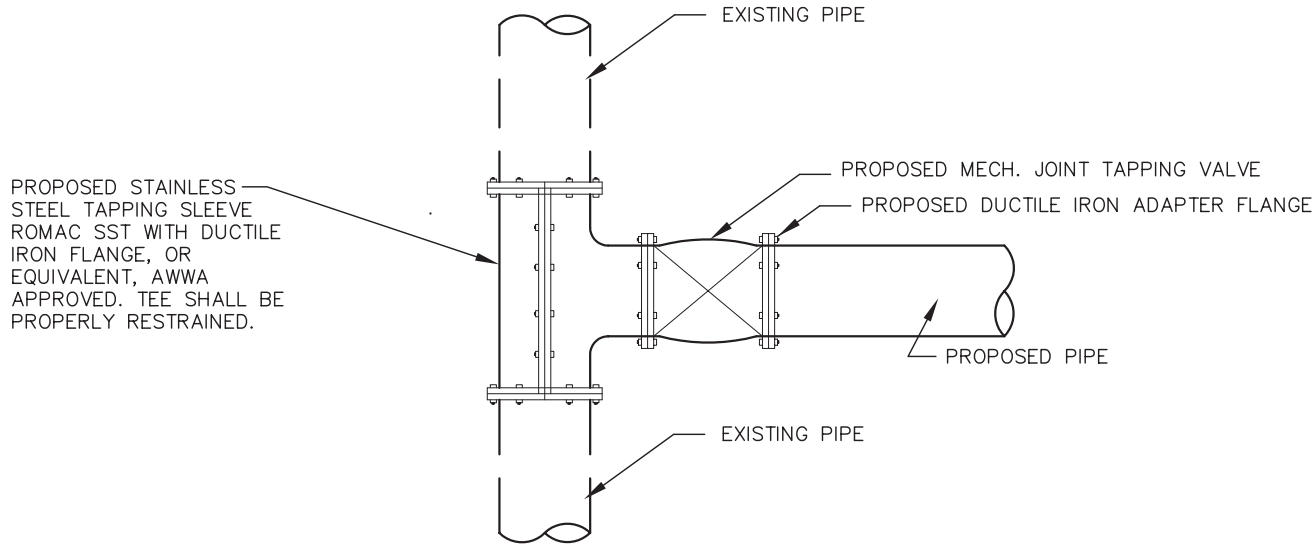

TAPPING SLEEVE AND VALVE DETAIL

ALL JOINTS TO BE RESTRAINED.
MECHANICAL RESTRAINT DEVICES SHALL BE AWWA ACCEPTED.

NOTES

- A.** BELL JOINT RESTRAINTS – USE FIELD LOCK BY U.S. PIPE OR APPROVED EQUIVALENT.
- B.** MECHANICAL JOINT RESTRAINTS – EBAA IRON MEGALUG RETAINER GLAND OR EQUIVALENT.
- C.** CONTRACTOR TO USE RESTRAINED JOINTS UNLESS THRUST BLOCKING IS PREAPPROVED FOR SPECIAL CONDITIONS BY THE CITY PRIOR TO THE BEGINNING OF CONSTRUCTION.

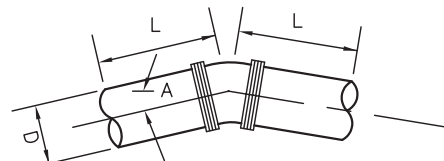
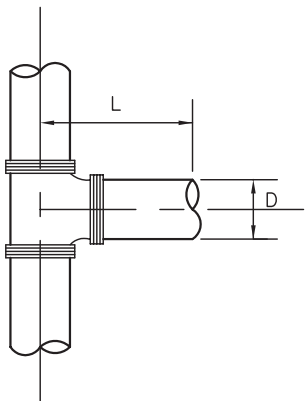
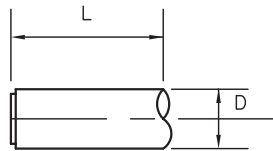

SEE TABLE FOR L,
REQUIRED LENGTH OF RESTRAINED JOINTS

		REQUIRED LENGTH OF RESTRAINED JOINTS IN FEET							
		D-DIAMETER OF PIPE							
A ~ DEGREE OF DEFLECTION		4"	6"	8"	10"	12"	16"	20"	24"
	11 1/4°	*	*	*	*	*	2	3	3
	22 1/2°	*	2	3	3	4	5	6	6
	45°	3	4	5	6	8	10	12	13
	90°	18	25	33	40	47	60	72	85
	TEE	18	25	33	40	47	60	72	85
END	18	25	33	40	47	60	72	85	

DESIGN PARAMETERS

LAYING CONDITIONS – TYPE 5
SOIL DESIGNATION – SILT
DEPTH OF COVER – 4'
DESIGN PRESSURE – 80 PSI
SAFETY FACTOR – 1.50
BARE PIPE
THIS CHART AND PARAMETERS
WILL BE UTILIZED UNLESS
APPROVED BY THE UTILITY
DIRECTOR.

REQUIRED LENGTH OF RESTRAINED JOINTS FOR WATER MAINS

* REQUIRED RESTRAINED JOINT
AT FITTING.

**CITY OF
URBANA**

**RESTRAINING JOINTS AND
TAPPING SLEEVE FOR WATER MAINS**

REVISIONS:

DATE
APPROVED:
01-13-06
PAGE No.

1167.52

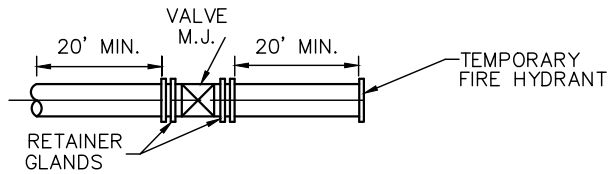

DETAIL - END OF WATER LINE

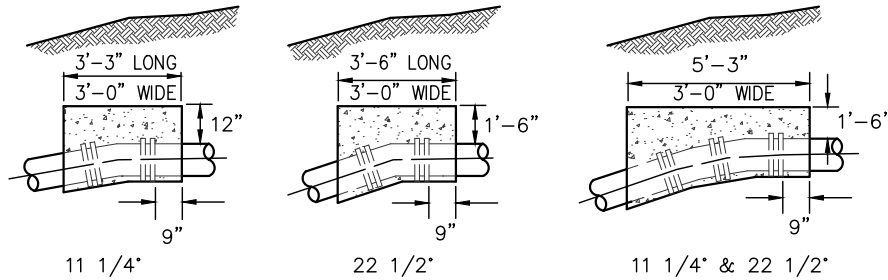

CONCRETE BLOCKING FOR VERTICAL BENDS

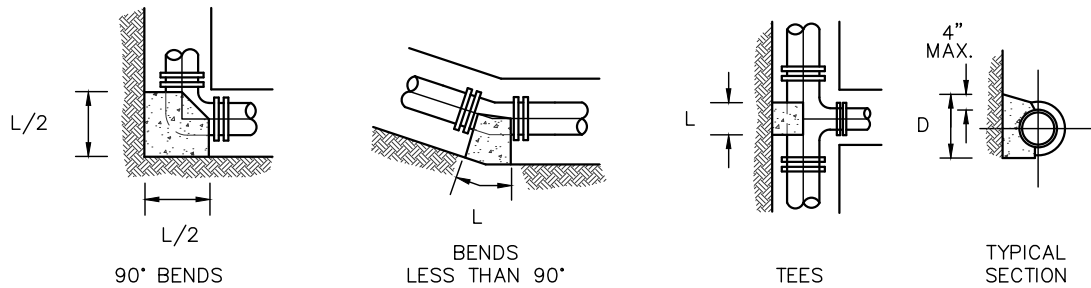

CONCRETE BLOCKING FOR HORIZONTAL BENDS

SIZE OF PIPE	BENDS							
	DEGREE OF BEND							
	11 1/4°		22 1/2°		45°		90°	
	L	D	L	D	L	D	L	D
3", 4", 6"	8"	6"	10"	6"	20"	6"	36"	6"
8"	9"	8"	14"	8"	24"	9"	50"	8"
12"	14"	12"	22"	12"	30"	16"	60"	15"
16"	18"	16"	24"	18"	33"	36"	70"	22"

RUN	TEES							
	BRANCH							
	3", 4", 6"		8"		12"		16"	
	L	D	L	D	L	D	L	D
3", 4", 6"	16"	6"	18"	12"				
8"	14"	8"	18"	12"				
12"	9"	12"	18"	12"	24"	18"		
16"	8"	16"	14"	16"	28"	16"	30"	26"

NOTES

A. CARE SHALL BE TAKEN TO KEEP CONCRETE AWAY FROM MECHANICAL JOINTS BY PLACING VISQUEEN OR OTHER APPROVED MATERIAL OVER PIPE BEFORE PLACING OF CONCRETE. BOLTS SHALL NOT BE ENCASED IN CONCRETE.

B. CONCRETE FOR BLOCKING VALVES AND FITTINGS SHALL CONFORM TO ODOT 499 CLASS QC-1.

C. CONTRACTOR SHALL USE THE THRUST BLOCKS AS SHOWN ONLY IF PREAPPROVED FOR SPECIAL CONDITION BY THE CITY PRIOR TO BEGINNING CONSTRUCTION AND IT IS DISCOURAGED.

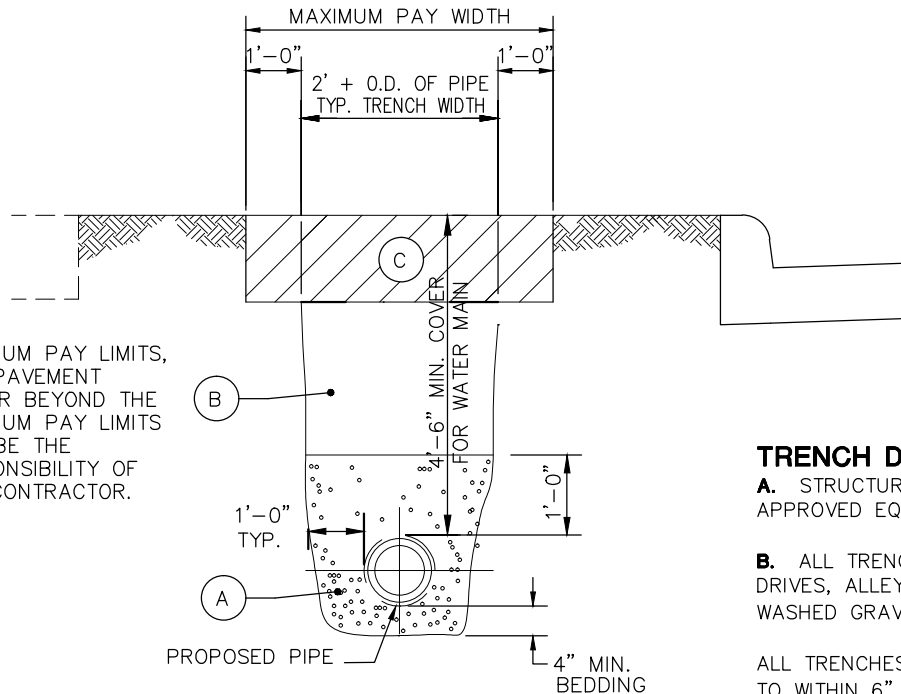

WATER MAIN TRENCH DETAIL

TRENCH DETAIL NOTES

- A.** STRUCTURAL BEDDING SHALL BE WASHED GRAVEL, ODOT 703 #8, #57, OR #67, OR OTHER APPROVED EQUIVALENT.
- B.** ALL TRENCHES WITHIN 5' OF PROPOSED OR EXISTING PAVEMENT, WALK, CURB AND GUTTER, DRIVES, ALLEYS, STONE AREAS, OR OTHER HARD SURFACE SHALL BE BACKFILLED WITH ODOT 703 WASHED GRAVEL TO WITHIN 12" OF SURFACE (#8, #57, OR #67).
- ALL TRENCHES BEYOND 5' OCCURRING IN SEED AREAS ARE TO BE BACKFILLED WITH NATIVE FILL TO WITHIN 6" OF SURFACE. NATIVE FILL IS TO BE COMPACTED TO 98% OF ASTM D698 STANDARD PROCTOR CURVE.
- C.** OFF-PAVEMENT AREAS SHALL BE PROVIDED WITH A MINIMUM OF 6" OF TOPSOIL OVER THE COMPACTED MATERIAL AND THEN SEEDED AND MULCHED PER ODOT ITEM 659.
- STREET AREAS SHALL FOLLOW TYPICAL SECTION 1167.20. GRAVEL DRIVE AREAS SHALL BE 12" OF 304 STABILIZED CRUSHED AGGREGATE. ASPHALT DRIVES SHALL BE REPAIRED WITH A MINIMUM OF 4" OF 448 SURFACE ASPHALT ON 8" OF 304 STABILIZED CRUSHED AGGREGATE. CONCRETE DRIVE AREAS SHALL BE 6" OF 452 PLAIN CONCRETE ON 6" OF 304 STABILIZED CRUSHED AGGREGATE.
- D.** THE OPEN ENDS OF ALL PIPES SHALL BE PLUGGED TO THE APPROVAL OF THE CITY BEFORE LEAVING THE WORK FOR THE NIGHT.
- E.** COMPACTED 304 IS TO BE USED UNDER CURB AND GUTTER AND SIDEWALKS WHERE DISTURBED BY CONSTRUCTION.

WATER MAIN CROSSING SEPARATION

WHENEVER A SANITARY SEWER AND WATER LINE MUST CROSS, THE SEWER SHALL BE LAID AT SUCH AN ELEVATION THAT THE CROWN OF THE SEWER IS AT LEAST 18 INCHES BELOW THE BOTTOM OF THE WATER LINE. IF IT IS ABSOLUTELY IMPOSSIBLE TO MAINTAIN THE 18-INCH VERTICAL SEPARATION, THE SANITARY SEWER SHALL BE CONSTRUCTED WITH WATER LINE TYPE MATERIALS WHICH WILL WITHSTAND A 50 PSI PRESSURE TEST. THESE REQUIREMENTS WILL EXTEND FOR A DISTANCE OF 10 FEET, MEASURED PERPENDICULAR, ON BOTH SIDES OF THE WATER LINE.

AT CROSSINGS, THE WATER MAIN SHALL HAVE A MINIMUM VERTICAL DISTANCE OF 18-INCHES FROM STORM AND SANITARY SEWERS. ALSO ONE FULL LENGTH OF WATER MAIN SHALL BE LOCATED SO THE JOINTS ARE AS FAR FROM THE STORM SANITARY SEWERS AS POSSIBLE.

MATERIAL SPECIFICATIONS

- A.** WATER MAIN SHALL BE AWWA C-151 DUCTILE IRON PIPE CLASS 53, WITH SLIP-ON JOINTS AND RUBBER GASKETS OR C900.
- B.** BELL JOINT RESTRAINTS – USE FIELD LOCK BY U.S. PIPE OR APPROVED EQUIVALENT.
- C.** MECHANICAL JOINT RESTRAINTS – EBAA IRON MEGALUG RETAINER GLAND OR EQUIVALENT.
- D.** FIRE HYDRANTS – AMERICAN DARLING B-84-B, CLOW MEDALLION, OR APPROVED EQUAL; MECHANICAL JOINT; TWO 2-1/2” HOSE NOZZLES, WITH NATIONAL STANDARD THREAD CONNECTIONS; ONE 4” I.D AND 4-1/2” O.D., 4 THREADS PER INCH PUMPER NOZZLE NATIONAL STANDARD THREADS; CONFORMING TO AWWA C-502; CW TO OPEN; BREAK FLANGES 3” ABOVE GRADE.
- E.** GATE VALVES (THRU 12”) – AWWA C-509, RESILIENT WEDGE, NON-RISING STEM, MECHANICAL JOINT, 200 PSI WORKING PRESSURE, CW TO OPEN, OPEN RIGHT WITH ARROW INDICATING OPEN DIRECTION.
- F.** VALVE BOXES – 3-PIECE CAST IRON 6” DIAMETER NOMINAL, ADJUSTABLE SCREW TYPE, COVER MARKED "WATER", DOMESTIC MADE ONLY.
- G.** SERVICE LINE – TYPE "K" COPPER TUBE WITH COMPRESSION TYPE FITTINGS OR CTS PLASTIC TUBING.
- H.** CURB STOP – BRASS CONFORMING TO AWWA C-800.
- I.** CURB BOXES – 2-1/2” SCREW TYPE, BUFFALO STYLE CAST IRON LID WITH PENTAGON HEAD PLUG EM2-45-67.
- J.** ALL SERVICE CONNECTIONS REQUIRE A METER.
- K.** VALVE SIZING
 - 6” TO AND INCLUDING 12” TO BE A GATE VALVE

HYDROSTATIC TEST

- A.** AFTER THE PIPE HAS BEEN LAID AND BACKFILLED, ALL NEWLY LAID PIPE OR VALVED SECTION, SHALL BE SUBJECTED TO HYDROSTATIC PRESSURE AND LEAKAGE TEST. ALL WATER MAINS MUST BE HYDROSTATICALLY TESTED (AWWA C-600). THE TESTS MUST BE PERFORMED BY THE CONTRACTOR IN THE PRESENCE OF A REPRESENTATIVE OF THE CITY OF URBANA. THE LEAKAGE TEST PRESSURE SHALL BE NOT LESS THAN 150 PSI. THE DURATION OF THE LEAKAGE TEST SHALL NOT BE LESS THAN 1 HOUR. HYDROSTATIC PRESSURE SHALL BE APPLIED BY MEANS OF A PUMP TAKING WATER FROM AN AUXILIARY SUPPLY. ALL PIPING MUST BE PROPERLY FILLED AND FLUSHED TO DISPEL ALL AIR BEFORE THE TEST IS MADE USING POTABLE WATER.
- B.** LEAKAGE IS DEFINED AS THE QUANTITY OF WATER TO BE SUPPLIED INTO THE NEWLY LAID PIPE, OR ANY VALVED SECTION THEREOF, NECESSARY TO MAINTAIN THE SPECIFIED LEAKAGE TEST PRESSURE AFTER THE PIPE HAS BEEN FILLED WITH WATER AND THE AIR EXPELLED.
- C.** DURING THE HYDROSTATIC TEST, A THOROUGH EXAMINATION OF ALL PIPING, FITTINGS, VALVES, HYDRANTS, ETC. SHALL BE PERFORMED. LEAKING JOINTS SHALL BE TIGHTENED AND THE TEST SHALL BE REPEATED UNTIL SATISFACTORY RESULTS ARE OBTAINED. CRACKED OR OTHERWISE DEFECTIVE MATERIAL SHALL BE REMOVED AND REPLACED AND THE TEST SHALL BE REPEATED UNTIL SATISFACTORY RESULTS ARE OBTAINED.

DISINFECTION

- A.** AFTER SATISFACTORY HYDROSTATIC TESTING, THE COMPLETED WATER WORK SHALL BE DISINFECTED IN ACCORDANCE WITH AWWA C-651 BY THE CONTRACTOR.
- B.** MAINTAIN PIPES FREE OF DIRT AND FOREIGN MATTER DURING CONSTRUCTION BY DEWATERING TRENCH AND SEALING OPEN PIPE BARRELS. THIS IS ALSO A REQUIREMENT IF REPAIRS OCCUR.
- C.** FLUSH CHLORINE SOLUTION TO WASTE INTO SANITARY SEWER AT A CONTROLLED RATE, NOT TO EXCEED 25 GPM. IF CHLORINE RESIDUAL DROPS IN 10 MG PER LITER, FLUSH MAIN AT 2 FPS AND REPEAT STERILIZATION PROCEDURE.
- D.** WATER SAMPLES – PERFORM BACTERIOLOGICAL TEST PER AWWA C-651. THIS TEST WILL BE PERFORMED BY THE CITY. TWO CONSECUTIVELY NEGATIVE RESULTS WILL CONSTITUTE A PASSABLE TEST. THE CONTRACTOR SHALL FURNISH ALL REQUIRED TESTING APPENDAGES OR EXCAVATION NEEDED BY THE CITY.
- E.** BACTERIA TEST-PORTS SHALL BE AT GROUND LEVEL AND WITH A VALVE INSTALLED.

AVG. TEST PRESSURE (PSI) BAR	ALLOWABLE LEAKAGE PER 1000 FT. (305M) OF PIPELINE (GPH+)									
	NOMINAL PIPE DIAMETER- INCHES									
	6	8	10	12	14	16	18	20	24	30
250(17)	0.71	0.95	1.19	1.42	1.66	1.90	2.14	2.37	2.85	3.56
225(16)	0.68	0.90	1.13	1.35	1.58	1.80	2.03	2.25	2.70	3.38
200(14)	0.64	0.85	1.06	1.28	1.48	1.70	1.91	2.12	2.55	3.19
175(12)	0.59	0.80	0.99	1.19	1.39	1.59	1.79	1.98	2.38	2.98
150(10)	0.55	0.74	0.92	1.10	1.29	1.47	1.66	1.84	2.21	2.76
120(9)	0.50	0.67	0.84	1.01	1.18	1.34	1.51	1.68	2.01	2.52

NOTES

- A.** NO WORK SHALL BE APPROVED OR ACCEPTED BY THE CITY UNLESS 2 WORKING DAYS NOTICE OF COMMENCING WORK IS GIVEN TO THE CITY.
- B.** ALL TEMPORARY PAVEMENT AND SIDEWALK SHALL BE MAINTAINED BY THE CONTRACTOR OR THE DEVELOPER AT HIS OWN EXPENSE IN A SUITABLE AND SAFE CONDITION FOR TRAFFIC UNTIL PERMANENT REPLACEMENT IS MADE OR THE PROJECT IS FINALLY ACCEPTED BY THE CITY, UNLESS OTHERWISE APPROVED.
- C.** THE MINIMUM LENGTH OF PIPE NIPPLES SHALL BE 18" UNLESS OTHERWISE APPROVED BY THE CITY.
- D.** ALL CUSTOMERS SHALL MEET BACKFLOW PREVENTION REQUIREMENTS AS PER CITY OF URBANA STANDARDS.
- E.** ALL WATERLINE CONSTRUCTION INCLUDING EXTENSIONS ON PRIVATE PROPERTY SHALL FOLLOW THE CITY STANDARDS, ODOT ITEM 638, AND AWWA STANDARDS WHICHEVER IS MORE RESTRICTIVE AS DETERMINED BY THE CITY.
- F.** OPERATION OF CITY FIRE HYDRANTS, VALVES, METERS, SERVICES, STOPS, AND ALL OTHER MECHANICAL INFRASTRUCTURE ITEMS IS STRICTLY PROHIBITED.
- G.** ALL WATER MAINS SHALL HAVE A MINIMUM DEPTH OF 4'-6" AND A MAXIMUM DEPTH OF 6'-0" FROM TOP OF PIPE TO SURFACE, UNLESS REQUIRED BY DESIGN.

PIPE

- A.** ALL PIPE FITTINGS SHALL BE DUCTILE IRON

B.

WATER MAIN MINIMUM SIZE UNLESS OTHERWISE APPROVED	
RESIDENTIAL	8"
COMMERCIAL	10"
INDUSTRIAL	12"
6" MAY BE CONSIDERED FOR LOOPING PURPOSES IN RESIDENTIAL AREAS	

- C.** DEADENDS ARE NOT PERMITTED AND MUST BE LOOPED UNLESS THEY ARE DEEMED UNPRACTICAL BY THE CITY ENGINEERING DEPARTMENT AFTER A REVIEW OF A WATER MAIN DESIGN. WHEN APPROVED, THEY SHALL BE TERMINATED WITH A FIRE HYDRANT AT THE END.

EXCAVATION AND PIPE LAYING

- A.** THE OPEN ENDS OF ALL PIPES SHALL BE CLOSED WITH A WATERTIGHT PLUG TO THE APPROVAL OF THE CITY BEFORE LEAVING THE WORK FOR THE NIGHT AND AT OTHER TIMES OF INTERRUPTION OF THE WORK.

FITTINGS, VALVES AND HYDRANTS

- A.** FITTINGS OR SPECIALS IN SIZES 3" THROUGH 64" SHALL CONFORM TO ALL REQUIREMENTS OF AWWA C-153. FITTINGS AND SPECIALS 24" AND SMALLER SHALL BE CLASS 350. FITTINGS AND SPECIALS 30" THROUGH 48" SHALL BE CLASS 250 WHILE THOSE 54" AND UP SHALL BE CLASS 150. FITTINGS AND SPECIALS SHALL HAVE MECHANICAL JOINTS AND SHALL BE DUCTILE IRON. CLUSTER VALVES WHENEVER POSSIBLE UNLESS APPROVED BY THE CITY.

B.

MAXIMUM SPACING UNLESS OTHERWISE APPROVED		
	HYDRANTS	VALVES
SINGLE & TWO FAMILY RESIDENTIAL	400'	600'
INDUSTRIAL, COMMERCIAL & MULTI-FAMILY	300'	500'

- C.** ALL TEES AND CROSSES SHALL BE VALVED IN EACH DIRECTION UNLESS OTHERWISE APPROVED.
- D.** NO VALVE SHALL BE OPERATED BY PERSONNEL OTHER THAN A REPRESENTATIVE EMPLOYED BY THE CITY.

UTILITY STAKING

- A.** OFFSETS EVERY 25' ON CURVES. OFFSETS EVERY 100' ON STRAIGHT SECTIONS. FLOW LINE OF WATER MAIN (CUT) MARKED EVERY 100' AND OFFSETS SHALL BE CLEARLY MARKED AND EVERY HYDRANT WITH TOP OF CURB ELEVATION.

BORING AND CASING PIPE DETAIL

- A.** SEE DETAILS ON PAGE 1167.26 AND 1167.27.

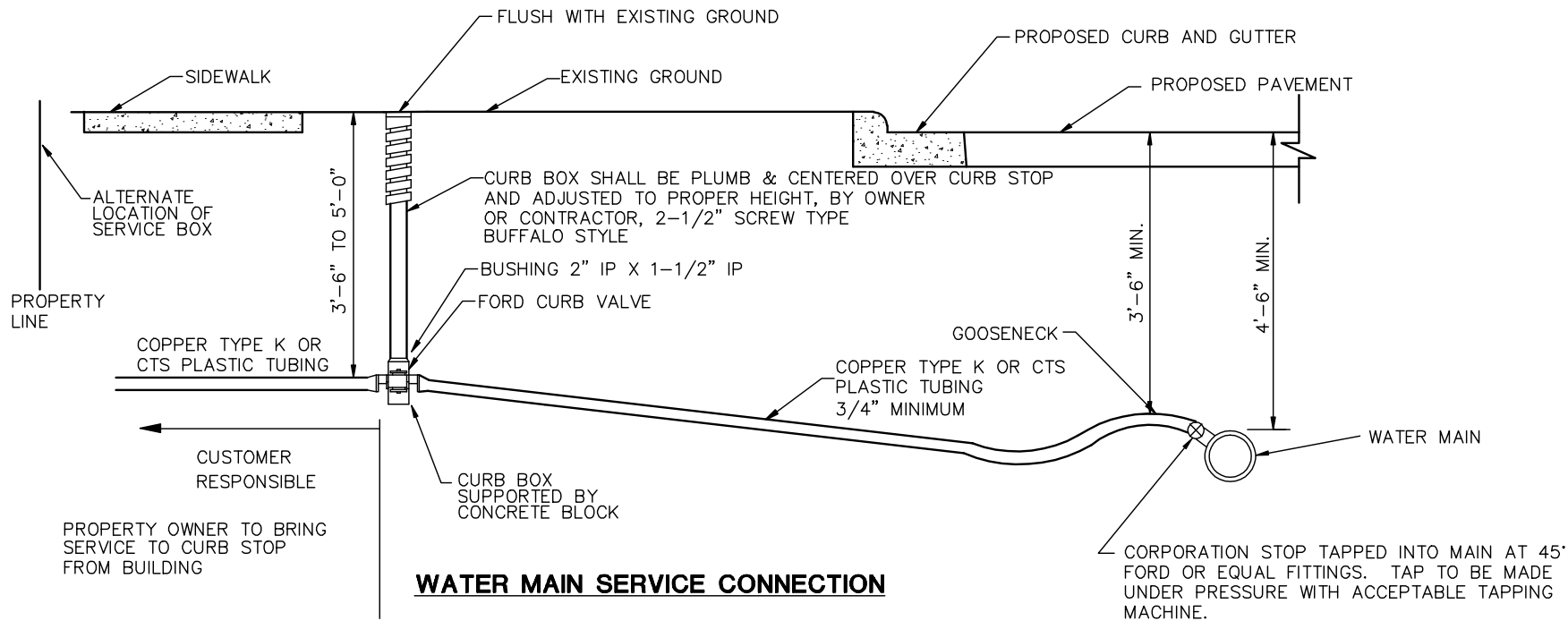

WATER MAIN SERVICE CONNECTION

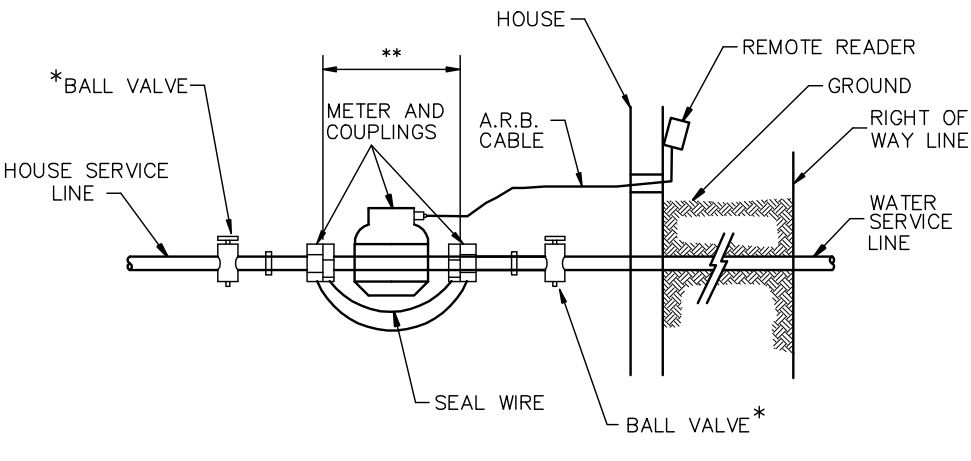

INSIDE WATER METER

*A GATE VALVE IS REQUIRED ON EACH SIDE OF ALL SERVICE LINES

ALL FORD PARTS				
	3/4"	1"	1-1/2"	2"
CORPORATION	F-1000-3	F-1000-4	FB-1000-6	FB-1000-7
CURB STOP	B-44-333	B-44-444	B-44-666	B-44-777

NOTES

- A. MINIMUM 3/4" WATER SERVICE SHALL BE COPPER TYPE K OR CTS PLASTIC TUBING.
- B. WATER SERVICE SHALL BE A MINIMUM OF 10' MEASURED HORIZONTALLY FROM THE SEWER SERVICE AND SHALL BE A MINIMUM OF 18" ABOVE THE CROWN OF THE SANITARY SEWER MAIN WHERE THE WATER SERVICE CROSSES THE SEWER MAIN. WATER SERVICE MAY BE LAID ON BENCH IN THE SEWER LATERAL TRENCH IF CROWN IS A LEAST 18" BELOW INVERT OF WATER SERVICE, AND THE MINIMUM DISTANCE BETWEEN THE WATER SERVICE AND THE SEWER LATERAL IS 5'-0".
- C. PROPERTY OWNER IS RESPONSIBLE FOR INSIDE METER FREEZE UP. CUSTOMER OR PLUMBER INSTALLS METER AND THE CITY INSTALLS REMOTE WIRE TO OUTSIDE. METERS MUST BE ON THE OUTSIDE WALL OF BUILDING.
- D. THE CURB BOX TO BE PLACED BETWEEN THE CURB AND PROPERTY LINE.

NOTES

- A.** OUTSIDE METER PITS ARE DISCOURAGED, METER PIT INSTALLATION SHALL OCCUR ONLY WITH THE UTILITY DIRECTOR'S PERMISSION. THIS INSTALLATION SHALL NOT BE ALLOWED UNLESS, IN THE JUDGEMENT OF THE UTILITY DIRECTOR, THIS IS THE ONLY PRACTICAL METHOD TO SERVICE THE ACCOUNT.
- B.** CONCRETE METER PIT, OTHERS MUST BE APPROVED PRIOR TO INSTALLATION.
- C.** METER PIT AND CURB STOP TO BE LOCATED AS DIRECTED BY THE CITY.
- D.** METER PIT AND METER PROVIDED BY CITY AND PAID FOR THROUGH TAPPING FEE.
- E.** UNSATISFACTORY INSTALLATION WILL RESULT IN WATER NOT BEING TURNED ON.
- F.** METER PIT LID MUST BE FLUSH OR 1" BELOW FINISHED GRADE. IF FRAME OF METER LID IS SHOWING, POSSIBILITY OF FREEZING OF METERS AND SERVICE LINES IS INCREASED. CITY'S RESPONSIBILITY STOPS AT THE FIRST SHUT-OFF VALVE.
- G.** PITS MUST USE METER YOKES

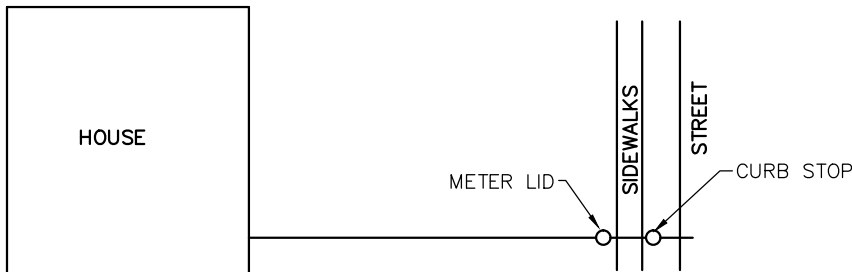
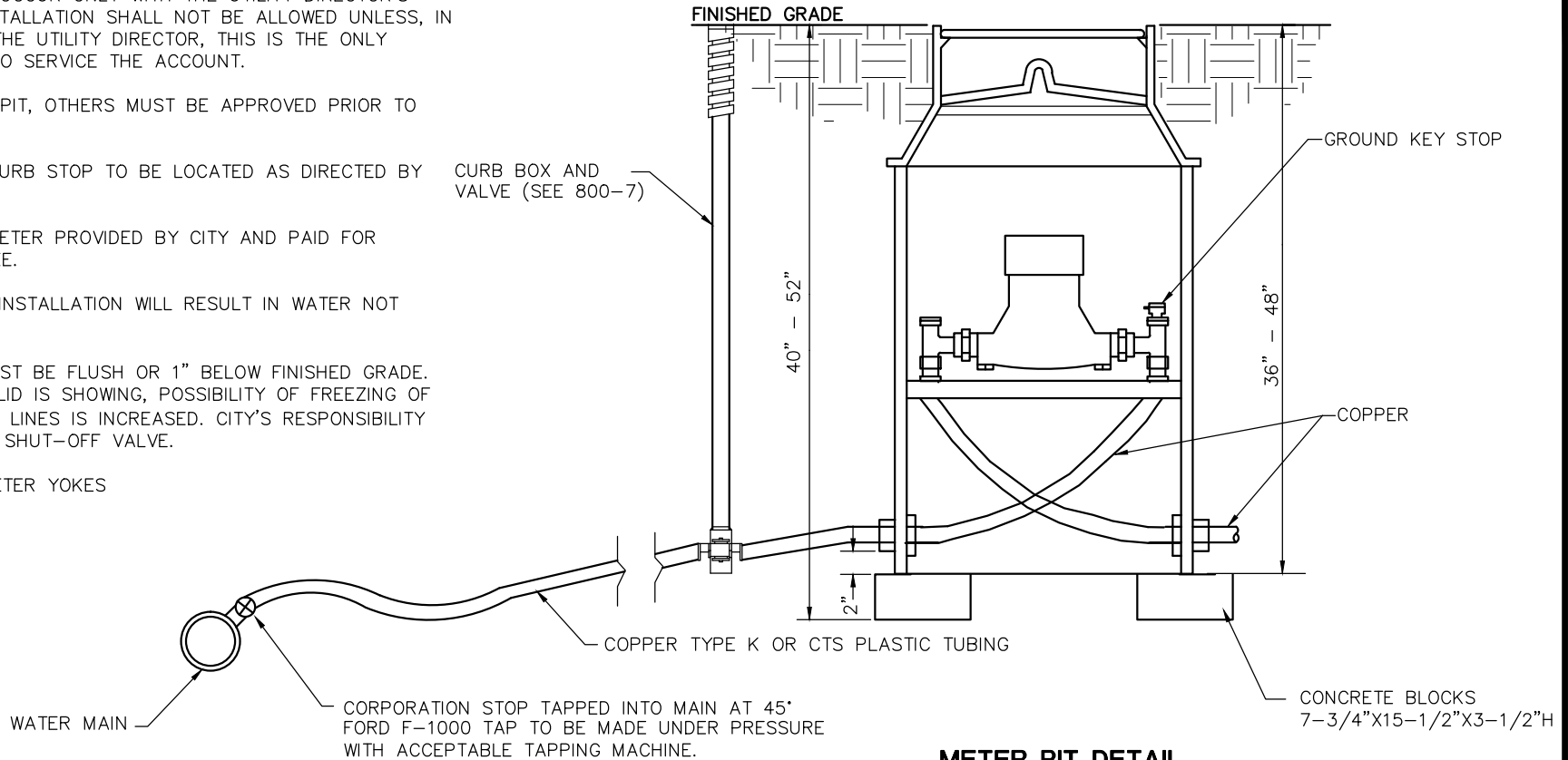

FORD CATALOG COPPERSETTER NO.	SERVICE PIPE SIZE	METER	SPREAD	TILE STYLE
V72-H	3/4"	5/8" X 3/4"	7-7/8"	20" DIA.
V72-H	3/4"	3/4"	9-3/8"	20" DIA.
V72-H	1"	1"	11-1/8"	24" DIA.

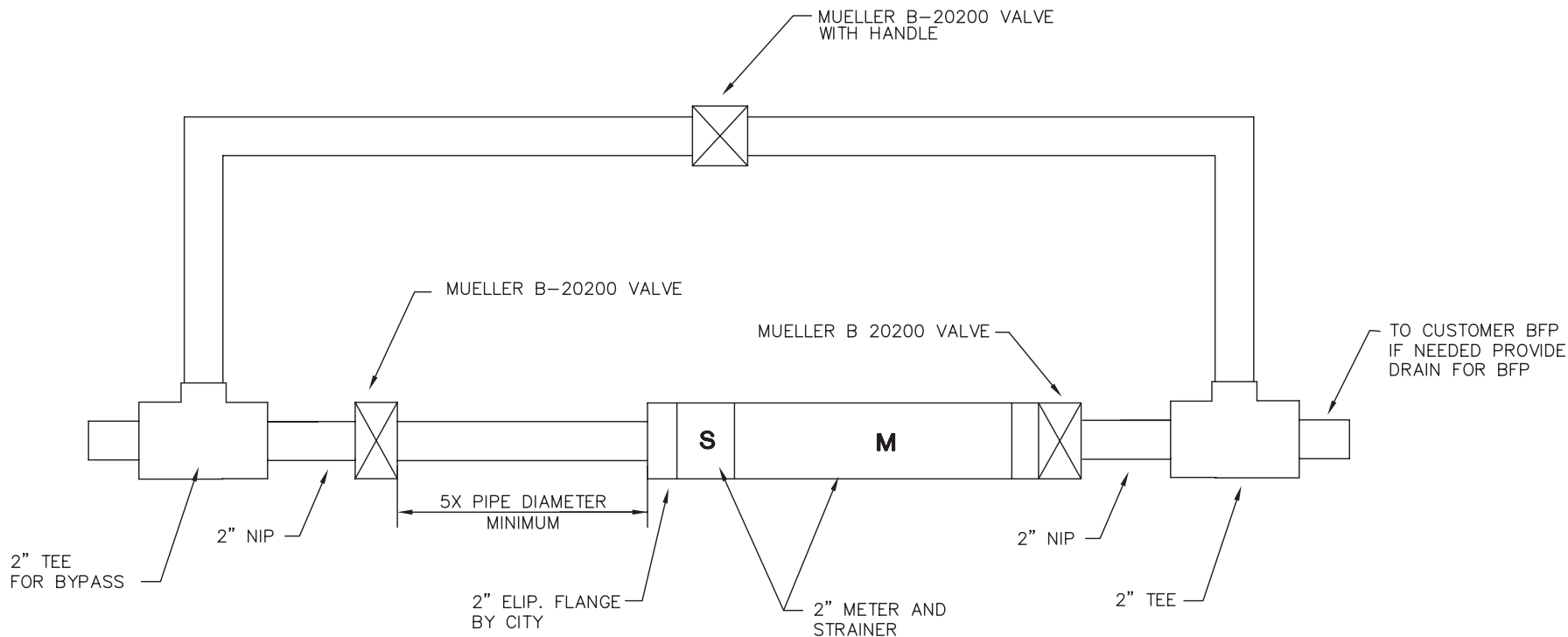

NOTES

- A.** CENTERLINE OF METER TO BE NO MORE THAN 36" FROM THE FLOOR.
- B.** METER MUST BE MOUNTED HORIZONTALLY INSIDE OF BUILDING.
- C.** USE STAINLESS STEEL OR BRASS NUTS AND BOLTS.
- D.** METER BYPASS ASSEMBLY AND METER SETTING TO BE CONSTRUCTED OF COPPER.
- E.** ALL PIPING TO BE THOROUGHLY SUPPORTED.
- F.** THE CITY IS NOT RESPONSIBLE FOR MAINTENANCE OF INSIDE PLUMBING.
- G.** PROVIDE APPROVED BACKFLOW PREVENTER REGISTERED WITH THE CITY.
- H.** PROVIDE TWO OR THREE (18-22 GAUGE) CONDUCTOR WIRE TO OUTSIDE OF BUILDING NEAR ELECTRIC METER.
- I.** BYPASS VALVE SHALL BE LOCKABLE.
- J.** CURB STOP IS ONLY ITEM INSTALLED OUTSIDE.

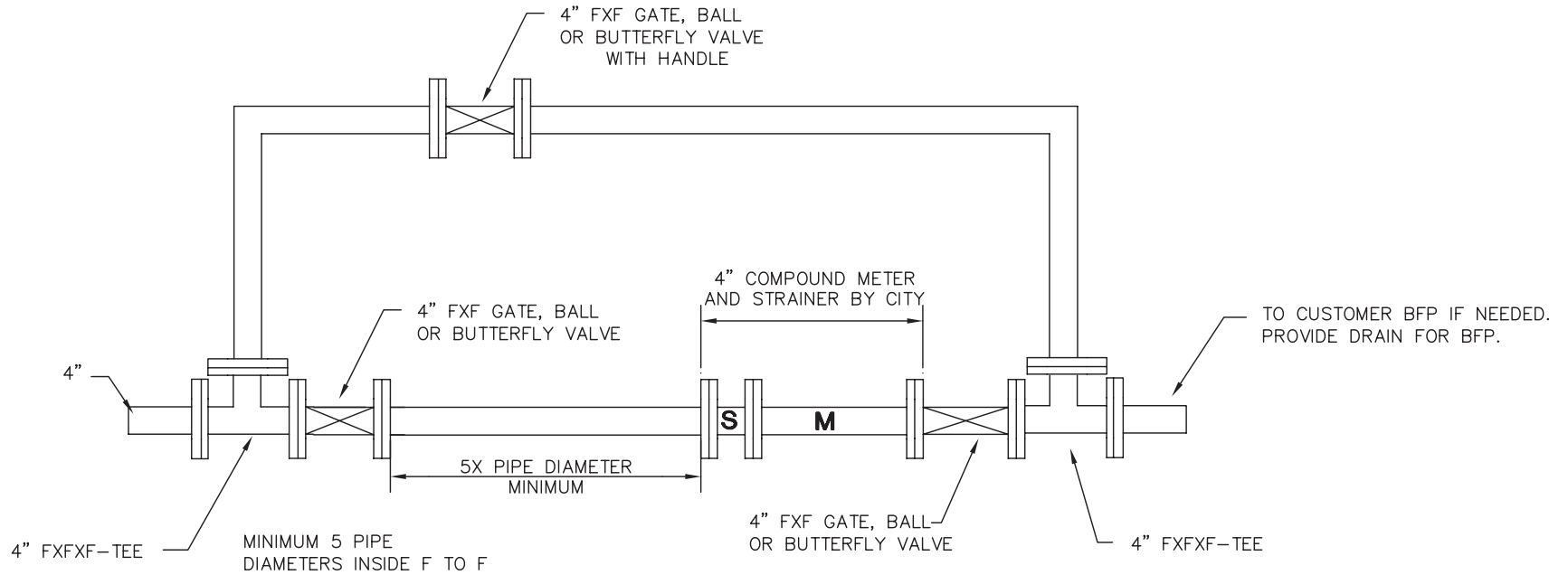

NOTES

- A.** CENTERLINE OF METER TO BE NO MORE THAN 36" FROM THE FLOOR.
- B.** METER MUST BE MOUNTED HORIZONTALLY.
- C.** FULL FACE FLANGE GASKETS AND STAINLESS STEEL OR BRASS NUTS AND BOLTS TO BE USED.
- D.** METER BYPASS ASSEMBLY AND METER SETTING TO BE CONSTRUCTED OF COPPER.
- E.** ALL PIPING TO BE THOROUGHLY SUPPORTED.
- F.** THE CITY IS NOT RESPONSIBLE FOR MAINTENANCE OF INSIDE PLUMBING.
- G.** PROVIDE APPROVED BACKFLOW PREVENTER REGISTERED WITH THE CITY.
- H.** PROVIDE THREE (18-22 GAUGE) CONDUCTOR WIRE TO OUTSIDE OF BUILDING NEAR ELECTRIC METER.
- I.** BYPASS VALVE SHALL BE LOCKABLE.

**CITY OF
URBANA**

4" COMPOUND METER WITH BYPASS

REVISIONS:	DATE APPROVED: 01-13-06
	PAGE No. 1167.60

NOTES

- A.** FOR 4" AND GREATER SERVICES.
- B.** PIPING SHALL BE D.I.P. CLASS 53 TO RIGID FLANGE. FROM RIGID FLANGE THROUGH METER VALVES AND BYPASS TO BE DUCTILE, COPPER OR BRASS.
- C.** FOR 1-1/2" AND 2" SERVICES: WATER DEPARTMENT RECOMMENDS THE USE OF COPPER PIPING.
- D.** FULL PORT GATE OR BALL VALVES IN LIEU OF VALVES MAY BE INSTALLED FOR 1-1/2" AND 2", METERS MUST BE LOCKABLE.
- E.** BYPASS MANDATORY FOR ALL METERS 1" AND LARGER. BYPASS VALVE TO BE LOCKABLE.
- F.** INSTALLATION FOR DUAL BACKFLOW PREVENTION DEVICES IS OPTIONAL FOR 1-1/2" -2" METERS.
- G.** ALTERNATE DESIGNS MAY BE SUBMITTED TO UTILITY DIRECTOR FOR APPROVAL.
- H.** PROVIDE SPREADER DEVICE FOR PROPER ALIGNMENT ON INSTALLATION OF METER SPREAD.
- I.** NO FLANGE ADAPTERS BEFORE INITIAL SHUT-OFF VALVE(S).

**METER SPREAD
(FACE TO FACE)**

1 1/2"	13"	FLANGED
2" COMPOUND	15"	FLANGED
2" SINGLE	17"	FLANGED
3" COMPOUND	17"	FLANGED
4"	20"	FLANGED
6"	24"	FLANGED
8" AND LARGER TO BE REVIEWED BY THE CITY		

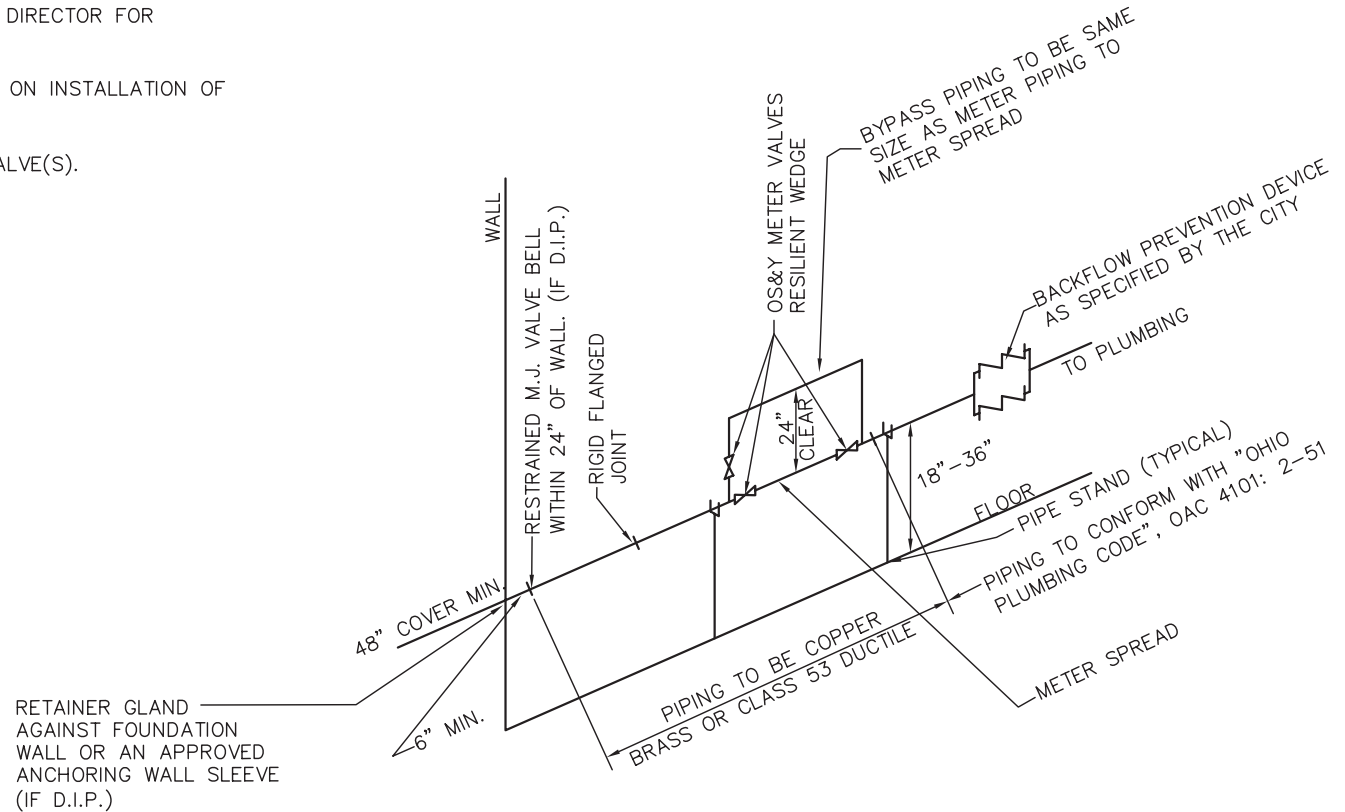

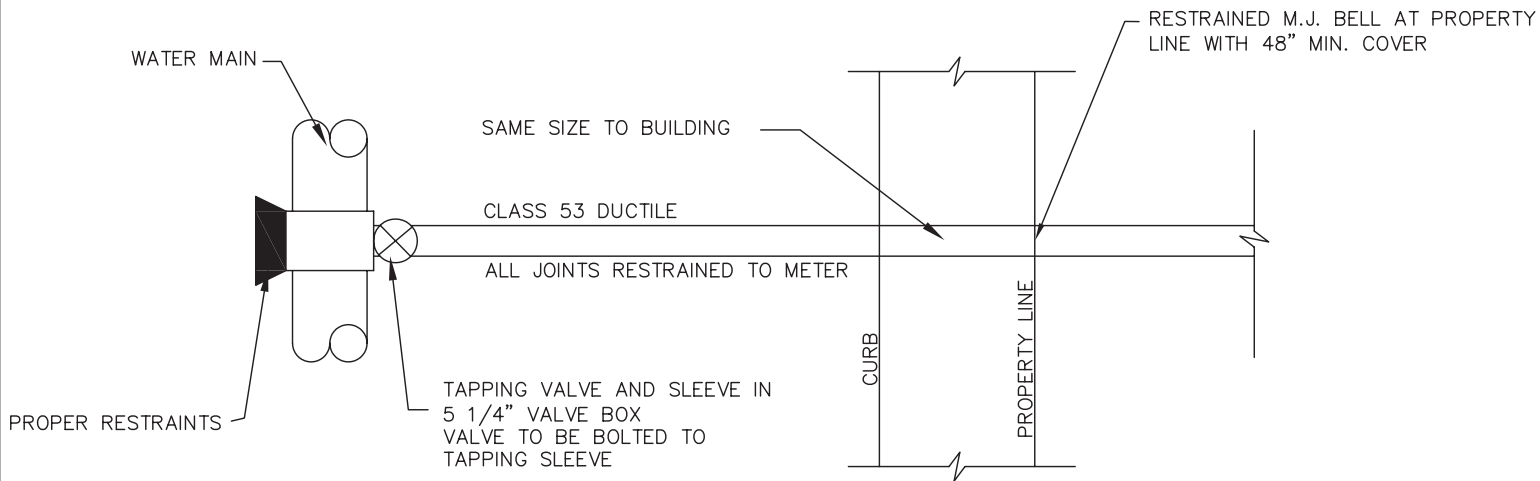

SERVICE TEES ARE PERMITTED IF

- A. SHOWN ON AN APPROVED SET OF CONSTRUCTION PLANS.
- B. 4" MINIMUM BRANCH AND SERVICE LINE WITH GATE VALVE WITHIN 3' OF MAIN.
- C. ALL TEE'S MUST BE PRE-APPROVED BY WATER SUPERINTENDENT.

NOTE

- A. METER SHALL BE LOCATED INSIDE THE BUILDING.
- B. EACH LINE SHALL HAVE SEPARATE METER AND TURN OFF.

**CITY OF
URBANA**

**4" AND LARGER WATER MAIN SERVICE
CONNECTION (DOMESTIC)**

REVISIONS:

DATE
APPROVED:
01-13-06
PAGE No.

1167.62

EXISTING DOMESTIC WATER WITH NO BACKFLOW DEVICE REQUIRED

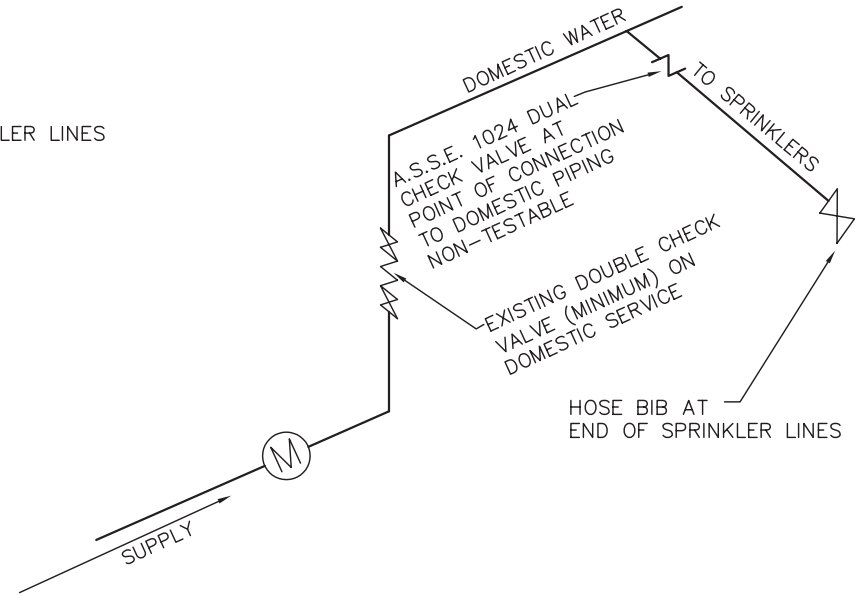
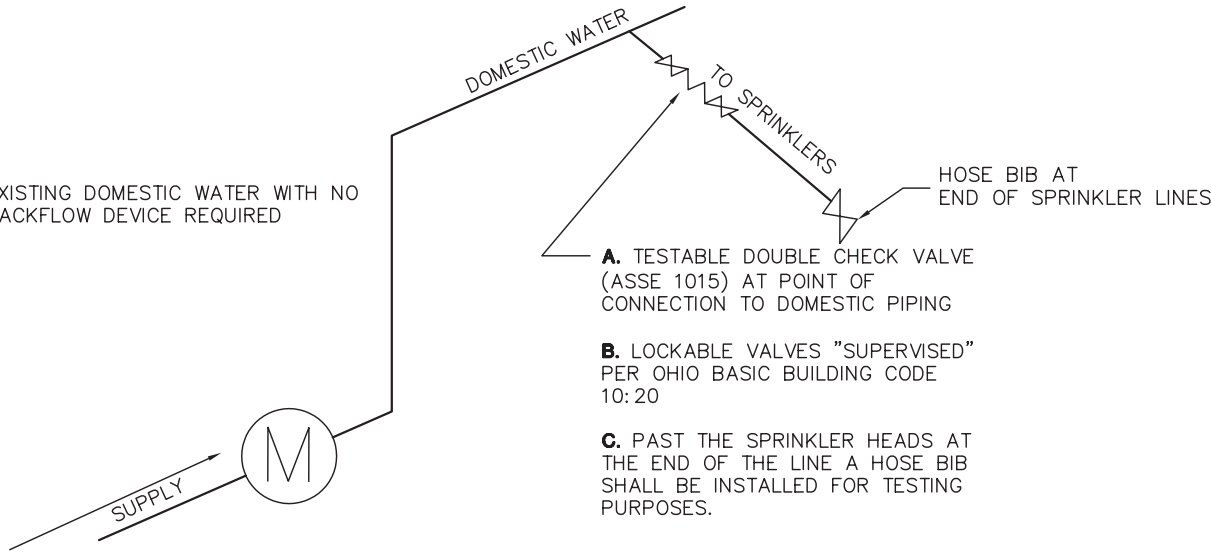

NOTE:

A. ADDITION OF BACKFLOW DEVICE ONTO EXISTING FIRE SUPPRESSION SYSTEM WILL AFFECT ORIGINAL FLOW CALCULATION

EXISTING DOMESTIC BACKFLOW

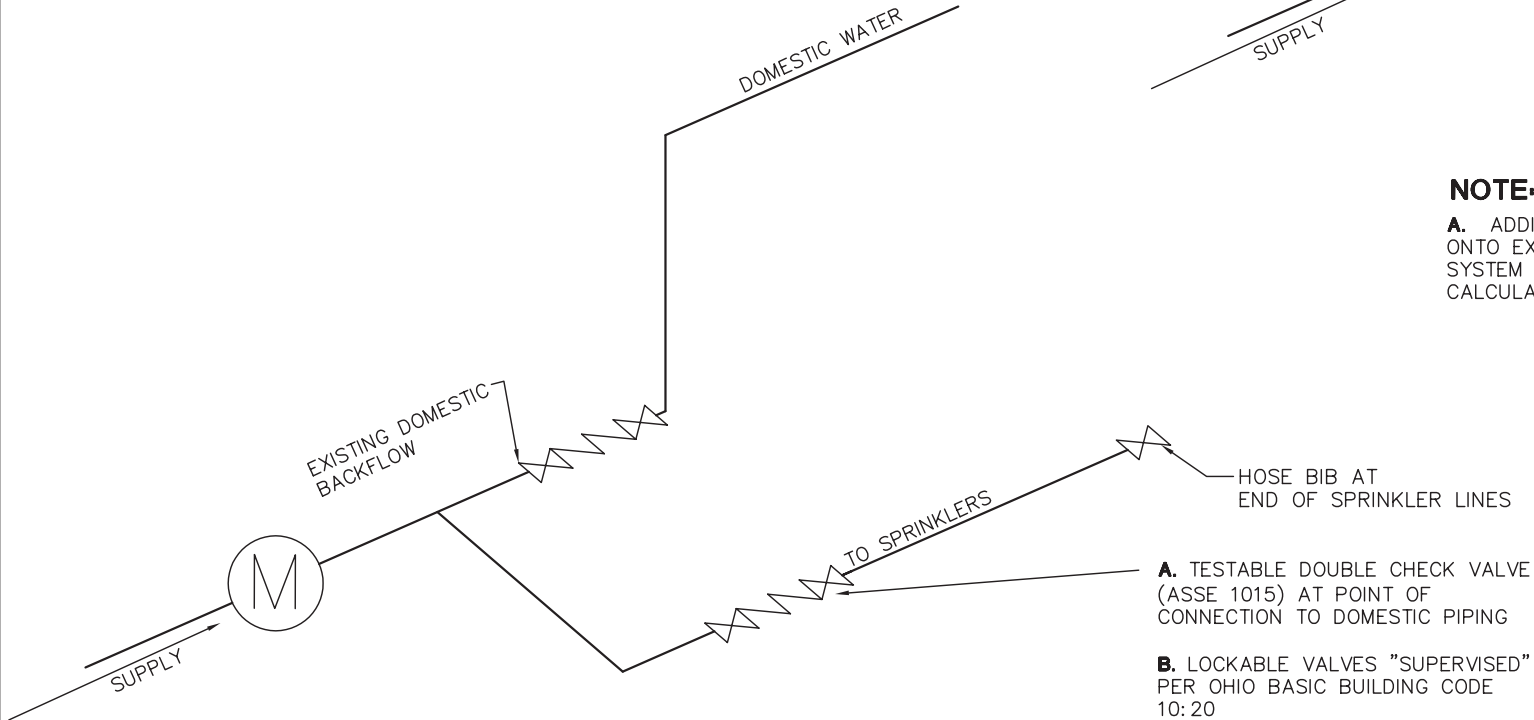

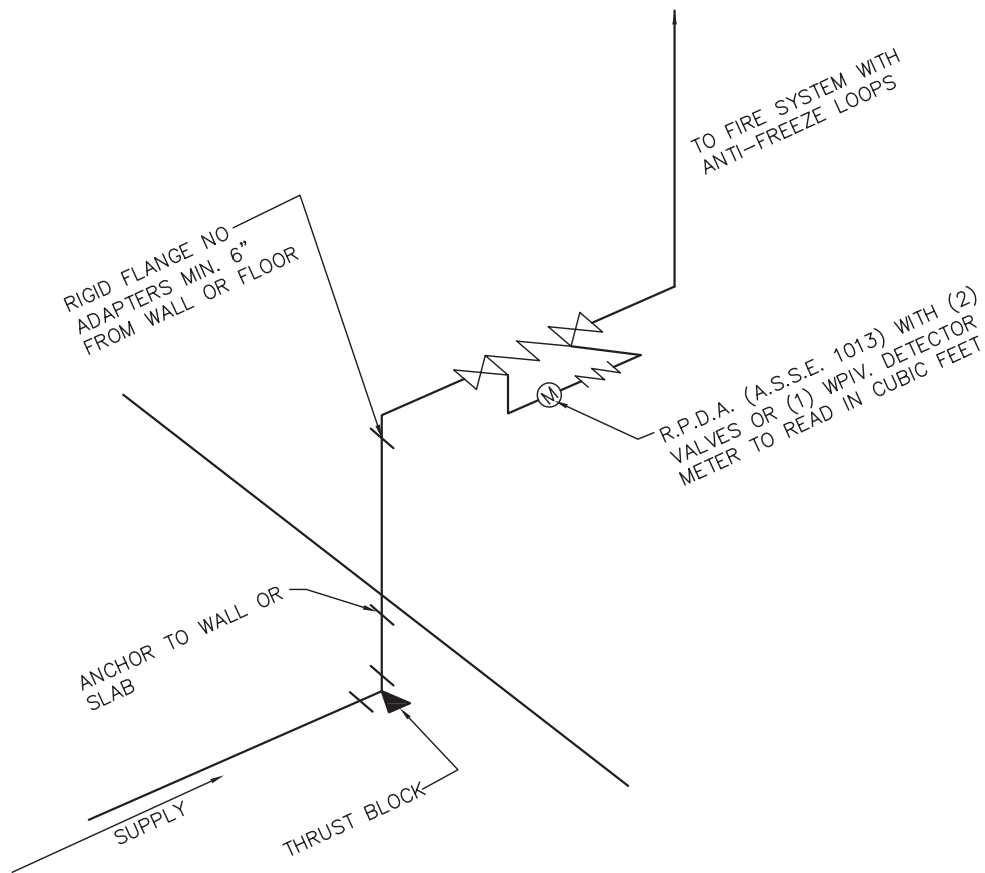

NOTE:

A. ALL BACKFLOW PREVENTION ASSEMBLIES SHALL BE DELIVERED FOR INSTALLATION COMPLETELY ASSEMBLED BY THE ORIGINAL MANUFACTURER WITH ALL COMPONENTS AS APPROVED.

B. ADDITION OF BACKFLOW DEVICE ONTO EXISTING FIRE SUPPRESSION SYSTEMS WILL AFFECT ORIGINAL FLOW CALCULATIONS.

C. CLASS 53 DUCTILE IRON TO VALVE. ALL JOINTS RESTRAINED.

D. ALL BACKFLOWS MUST BE RPZ

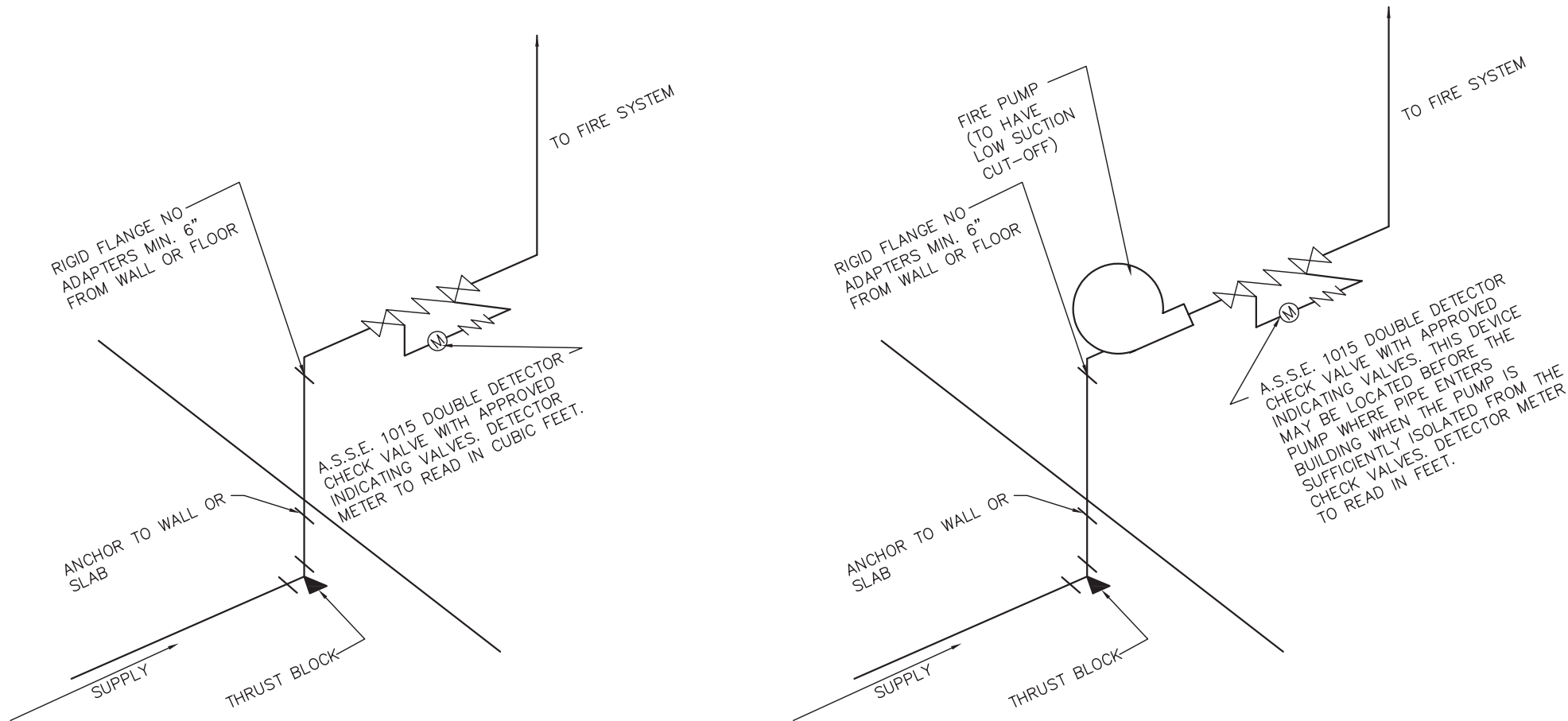

NOTE:

A. ALL BACKFLOW PREVENTION ASSEMBLIES SHALL BE DELIVERED FOR INSTALLATION COMPLETELY ASSEMBLED BY THE ORIGINAL MANUFACTURER WITH ALL COMPONENTS AS APPROVED.

B. CLASS 53 DUCTILE IRON TO VALVE. ALL JOINTS RESTRAINED.

**CITY OF
URBANA**

**DOUBLE DETECTOR
CHECK VALVE ASSEMBLY DETAIL**

REVISIONS:

DATE
APPROVED:
01-13-06
PAGE No.

1167.65

NOTES

- A.** SEE "STANDARDS FOR TAPS, SERVICES AND METERS" FOR TYPICAL NOTES.
- B.** BACKFLOW PREVENTION DEVICE REQUIRED—CONTACT WATER METER DEPARTMENT FOR APPROVED DEVICE.
- C.** PROVIDE APPROVED DRAIN FOR IRRIGATION SYSTEM.
- D.** ALTERNATE DESIGNS MUST BE SUBMITTED FOR APPROVAL.
- E.** IF METER IS INSTALLED INSIDE CRAWL SPACE AREA, IT SHALL BE PLACED WITHIN 2' OF OPENING.
- F.** THE CURB BOX MUST BE BROUGHT UP TO FINISH GRADE.
- G.** NO OUTLETS ARE ALLOWED BETWEEN METER AND THE BACKFLOW PREVENTER OR HOSE BIBB VACUUM BREAKER WITH THE EXCEPTION OF ONE SCREW PLUG-IN TAP FOR WINTERIZING/DRAINAGE PURPOSES.
- H.** THE UNDERGROUND WATER SERVICE SHALL BE K-COPPER UP TO THE BACKFLOW PREVENTER OR HOSE BIBB VACUUM BREAKER.
- I.** IN CASE OF ADD-ON CONSTRUCTION (WITH AN EXISTING DOMESTIC METER AND SERVICE) LEAD FREE SOLDERED JOINTS WILL BE ACCEPTED AT THE TAKE-OFF TEE ONLY.
- J.** THE INSTALLATION SHALL BE INSPECTED BY THE CITY.

**INSTRUCTIONS FOR
THE INSTALLATION OF IRRIGATION METERS
AND
BACKFLOW PREVENTERS FOR IRRIGATION**

- A.** MAKE DRAWING OF THE PROPOSED IRRIGATION SYSTEM. THIS DRAWING MUST BE APPROVED BY CITY AND CHAMPAIGN COUNTY HEALTH DEPARTMENT.
- B.** ALL WORK SHALL BE DONE IN ACCORDANCE WITH THE CITY "STANDARDS FOR TAPS, SERVICES AND METERS".
- C.** GET THE NECESSARY PERMITS.
 - 1) TAPPING FEE
- D.** GET FORMS AT CHAMPAIGN COUNTY HEALTH DEPARTMENT FOR EACH BACKFLOW PREVENTER TO BE INSTALLED, PRIOR TO DOING THE WORK.
- E.** AFTER THE BACKFLOW PREVENTERS HAVE BEEN INSTALLED, PLEASE FILL OUT THE FORMS COMPLETELY WITH THE OWNER/LEASEHOLDER'S NAME, ADDRESS (WHERE THE BACKFLOW PREVENTER WAS INSTALLED), LOCATION OF THE BACKFLOW PREVENTER, SIZE, MAKE, MODEL, TEST RESULTS BY A LICENSED PLUMBER, ANNUAL TEST RESULTS THERE AFTER, AND SERIAL NUMBER OF THE BACKFLOW PREVENTER. PLEASE RETURN THE COMPLETED FORMS TO THE CITY.
- F.** CONTACT BOTH CITY AND THE CHAMPAIGN COUNTY HEALTH DEPARTMENT AFTER THE WORK HAS BEEN COMPLETED. BACKFLOW PREVENTERS HAVE TO BE INSPECTED BY BOTH CITY AND THE CHAMPAIGN COUNTY HEALTH DEPARTMENT.
- G.** SEPARATE VALVES, ONE BEFORE AND AFTER, MUST BE PLACED NEAR THE BACKFLOW PREVENTER WHENEVER THE EXISTING BACKFLOW IS REMOVED.

HOSE BIBB

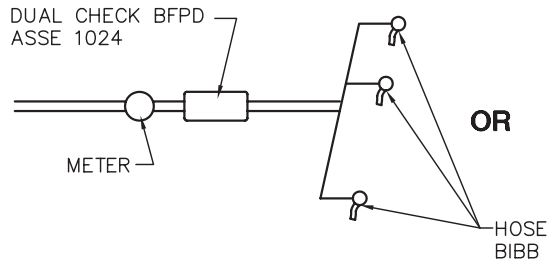

NON-RECERTIFIABLE BFPDS
(ASSE 1001, ASSE 1011) ON
HOSE BIBBS

YARD HYDRANT

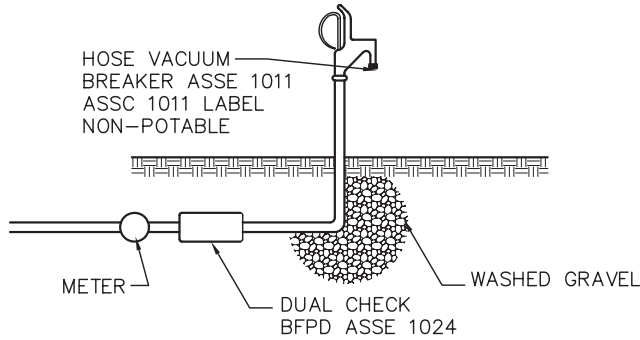

YARD MAIN SYSTEM ARRANGEMENT

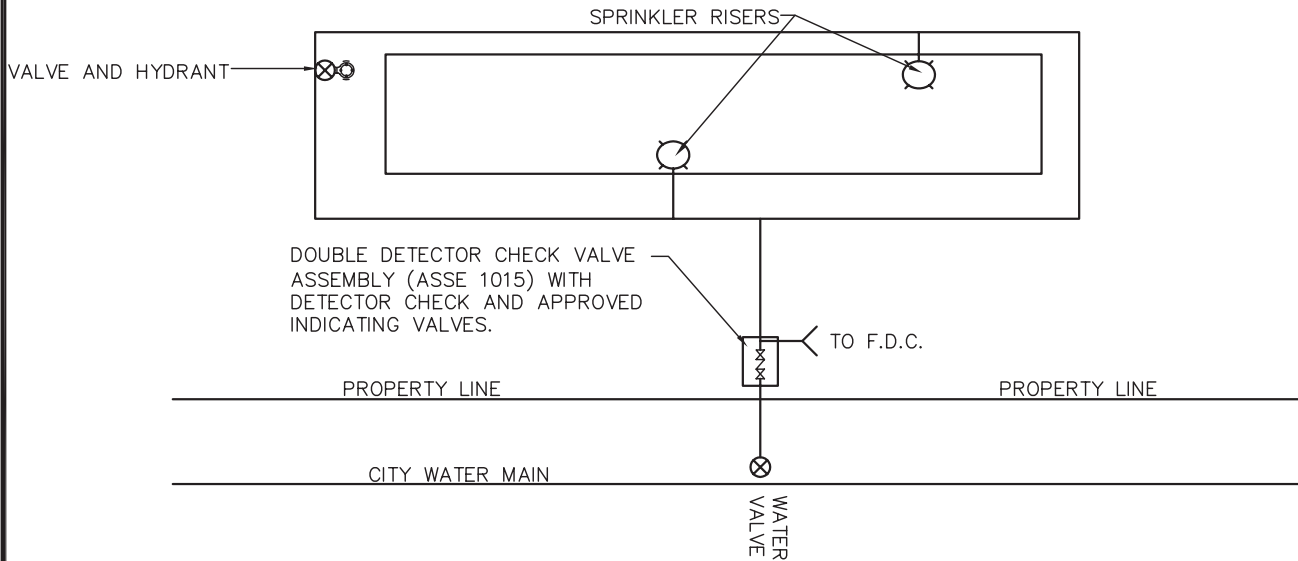

SPRINKLER SYSTEM

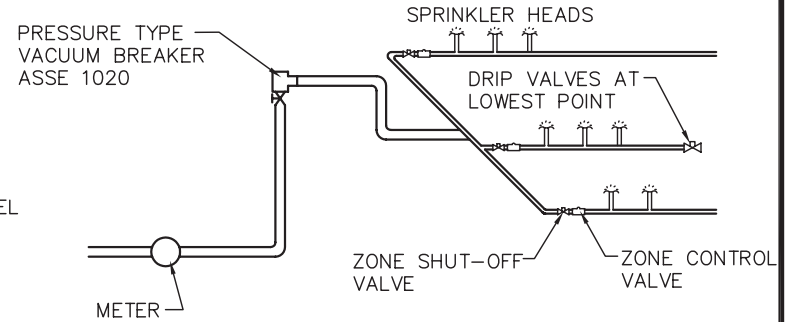

CONDITIONS

- A.** SHUT-OFF VALVES ARE ALLOWED DOWNSTREAM OF THE BFPD.
- B.** THE PRESSURE TYPE VACUUM BREAKER MUST BE A MINIMUM OF 12" ABOVE THE HIGHEST SPRINKLER HEAD.

NOTES

- A.** A DRAWING OF EACH PROPOSED IRRIGATION SYSTEM MUST BE APPROVED BY THE CITY PRIOR TO CONSTRUCTION.
- B.** IF IRRIGATION SYSTEM IS NONE OF THE ABOVE, USE A REDUCED PRESSURE BACKFLOW PREVENTER, (ASSE 1013), AFTER THE WATER METER.

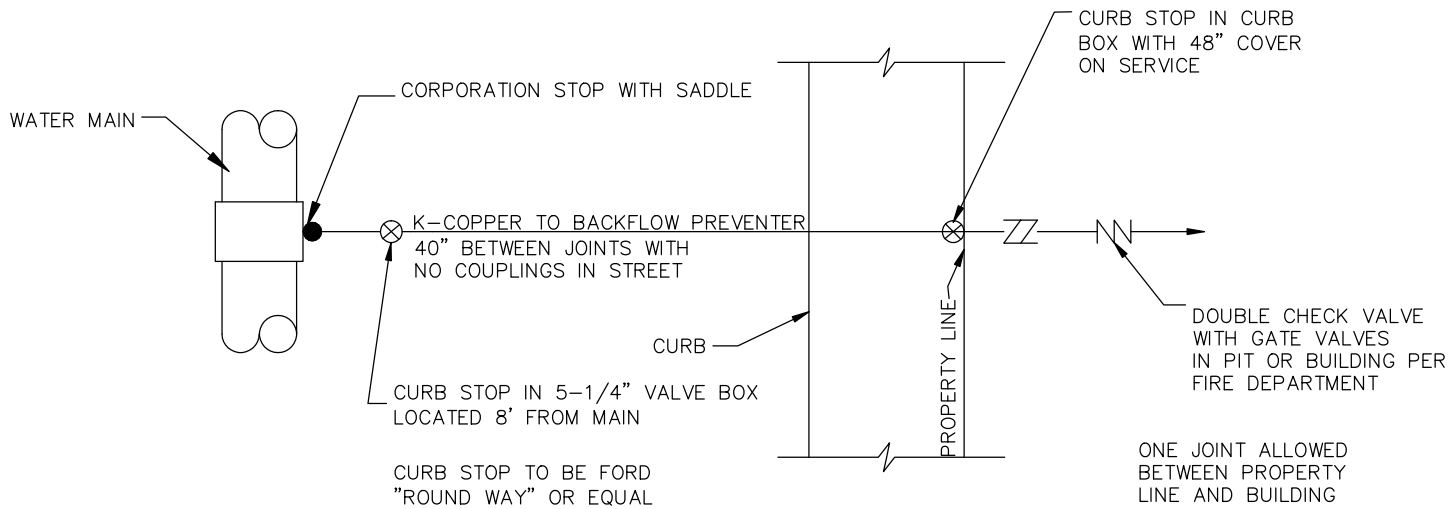

2" FIRE LINE SERVICE
(METER REQUIRED)

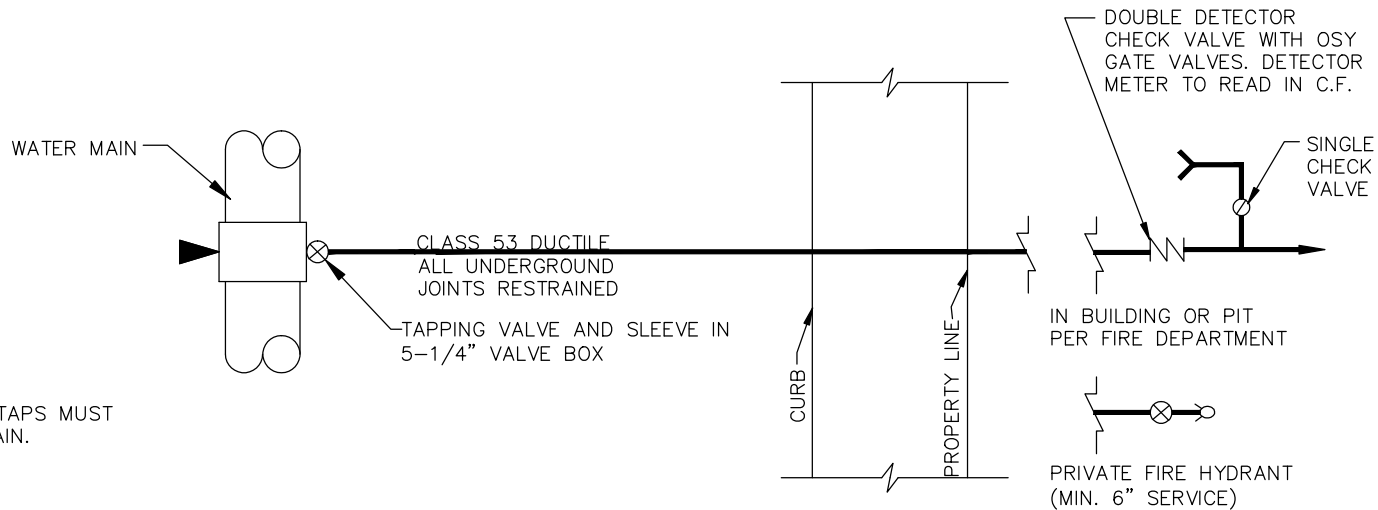

NOTE:
DOMESTIC AND FIRE PROTECTION TAPS MUST
BE SEPARATE TAPS AT WATER MAIN.

4" AND LARGER FIRE LINE SERVICE
(METER REQUIRED)

WALL/POST INDICATOR
VALVES SHALL BE ADDED
ON PREMISES AT FIRE
DEPARTMENT REQUEST

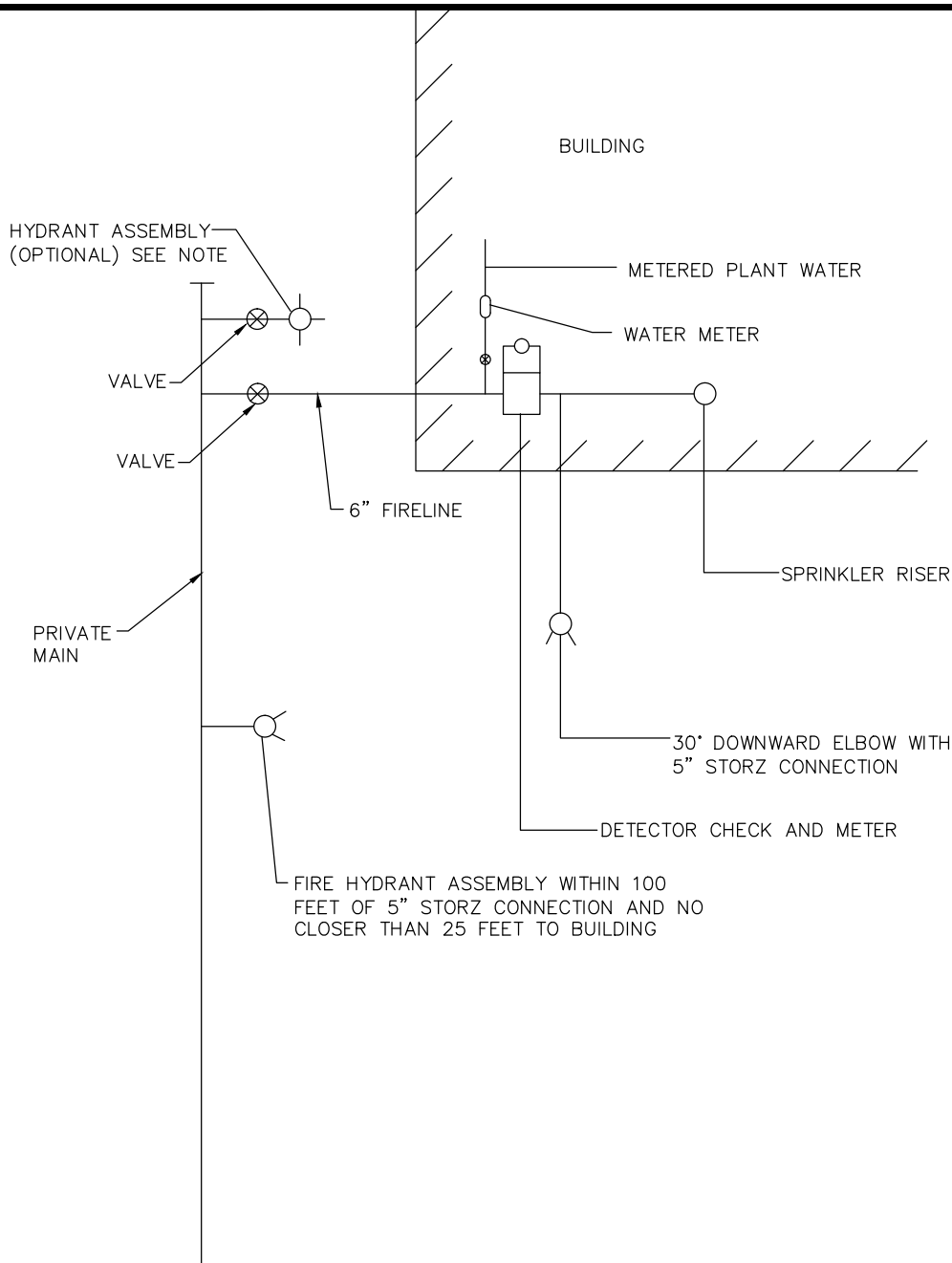

REVIEW AND FEES

A. FIVE SETS OF SITE PLANS SHALL BE SUBMITTED TO THE CITY ZONING INSPECTOR TO BE REVIEWED BY THE ZONING INSPECTOR, FIRE DEPT. OFFICIAL, UTILITY DIRECTOR, CITY ENGINEER AND THE PLANNING COORDINATOR.

TESTING

A. THE CITY FIRE DEPARTMENT PERSONNEL WILL CONDUCT SELECTIVE FIRE HYDRANT TESTING FOR RESIDUAL PRESSURE. THE TESTING IS DONE ANNUALLY OR WHENEVER NEEDED. PROCEDURES OF THE HYDRANT FLOW TEST ARE FOLLOWED FROM THE FOURTH EDITION OF THE IFSTA MANUAL "WATER SUPPLIES FOR FIRE PROTECTION". TESTING PROCEDURES ARE ON FILE AT THE MAIN FIRE STATION AND AT THE CITY ENGINEERING OFFICE.

GENERAL NOTES

A. FIRE LINE AND HYDRANT INSTALLATION, TESTING AND MATERIALS SHALL BE THE SAME SPECIFICATIONS AS STATED IN THE CONSTRUCTION STANDARDS AND DRAWINGS. THESE CONSTRUCTION STANDARDS AND DRAWINGS SHALL ALSO BE FOLLOWED FOR WATERLINE EXTENSIONS ON PRIVATE PROPERTY THAT WILL PROVIDE FIRE LINE OR DOMESTIC WATER SERVICE.

B. CITY OF URBANA FIRE LINE REVIEW FORMS SHALL BE COMPLETED WITH TWO SETS OF PLANS FURNISHED TO THE CITY FIRE CHIEF.

C. CITY OF URBANA CERTIFIED I.S.O TEST SHALL NOT BE CERTIFIED TO THE STATE OF OHIO UNTIL THE FOLLOWING ITEMS HAVE BEEN COMPLETED.

- 1.) ONE SET OF DRAWINGS FURNISHED TO THE CITY ENGINEERING DEPARTMENT AND
- 2.) FIRE LINE INSTALLATION FORM SHALL BE COMPLETE

D. NO ADDITIONAL BOOSTER PUMPS SHALL BE INSTALLED FOR THE DOMESTIC LINE.

E. A CONTRACTOR REGISTERED THROUGH THE CITY OF URBANA SHALL PERFORM MAINTENANCE OF PRIVATE SERVICE LINES AND HYDRANTS. COORDINATION OF YEARLY HYDRANT FLUSHINGS WILL BE HANDLED THROUGH THE CITY FIRE DEPARTMENT.

F. FIRE LINE MAINTENANCE SHALL BE PERFORMED BY A CERTIFIED FIRE LINE CONTRACTOR THROUGH THE OFFICE OF THE STATE FIRE MARSHALL.

G. TESTING OF FIRE LINES SHALL BE PERFORMED BY A STATE-APPROVED FIRE LINE INSTALLER.

H. A CERTIFIED FIRE LINE CONTRACTOR LICENSED THROUGH THE OFFICE OF THE STATE FIRE MARSHALL SHALL PERFORM THE WORK.

I. THERE SHALL BE AN EXISTING OR NEW HYDRANT INSTALLED WITHIN 100 FEET OF THE 5" STORZ CONNECTION AND NO CLOSER THAN 25 FEET TO A BUILDING. EXCEPTIONS MUST BE SUBMITTED TO THE CITY FIRE PROTECTION OFFICIALS.

SPRINKLER NOTES

A. HYDRAULIC CALCULATIONS FROM THE SPRINKLER SYSTEM DESIGNER SHALL BE SUBMITTED TO THE URBANA FIRE DEPT. WITH THE SITE PLAN FOR REVIEW.

B. INSTALLATION OF A FLOW SENSOR MONITOR WILL BE REQUIRED TO REPORT TO AN APPROVED MONITORING SYSTEM. (I.E. POLICE, PRIVATE STATION, ETC.)

NOTES

- A.** THE FIRE LINE SHALL BE DEFINED AS "THE LINE FROM THE WATER MAIN THAT SUPPLIES THE SYSTEM.
- B.** MINIMUM FIRE LINE SIZE SHALL BE 6".
- C.** A FIRE HYDRANT SHALL BE INSTALLED WITHIN 100 FEET OF THE 5" STORZ CONNECTION.
- D.** FIRE LINE CHARGES SHALL BE BASED ON SIZE OF RISER.
- E.** CONTRACTOR SHALL INSTALL A REDUCED PRESSURE PRINCIPLE BACKFLOW PREVENTOR ON FIRE LINE PRIOR TO RISER.
- F.** LIMITED AREA SPRINKLERS SHALL BE CONNECTED BEFORE METER.
- G.** ALL MATERIAL AND CONSTRUCTION METHODS SHALL CONFORM TO CITY STANDARDS.
- H.** PRIVATE WATER MAIN SHALL REMAIN PRIVATE UNLESS ACCEPTED BY THE CITY AND AN EASEMENT IS GRANTED.
- I.** ALL FIRE LINES SHALL BE TESTED AT 200psi. SEE HYDROSTATIC TEST ON PAGE 1167.55 FOR ADDITIONAL REQUIREMENTS. FIRE DEPARTMENT TO WITNESS TEST.

TESTING PROCEDURES FOR EXAMPLE #1

- A.** FIRE LINE SHALL BE INSTALLED, INSPECTED AND CERTIFIED BY A STATE LICENSED FIRE LINE INSTALLER.
- B.** PRIVATE WATER MAIN CAN BE INSTALLED BY THE GENERAL CONTRACTOR AND MUST BE INSPECTED BY THE CITY. CITY SHALL PERFORM DISINFECTION AND BACTERIA TEST ON BOTH THE FIRE LINE AND PRIVATE WATER MAIN AFTER PRESSURE TEST HAVE BEEN PERFORMED AND APPROVED.

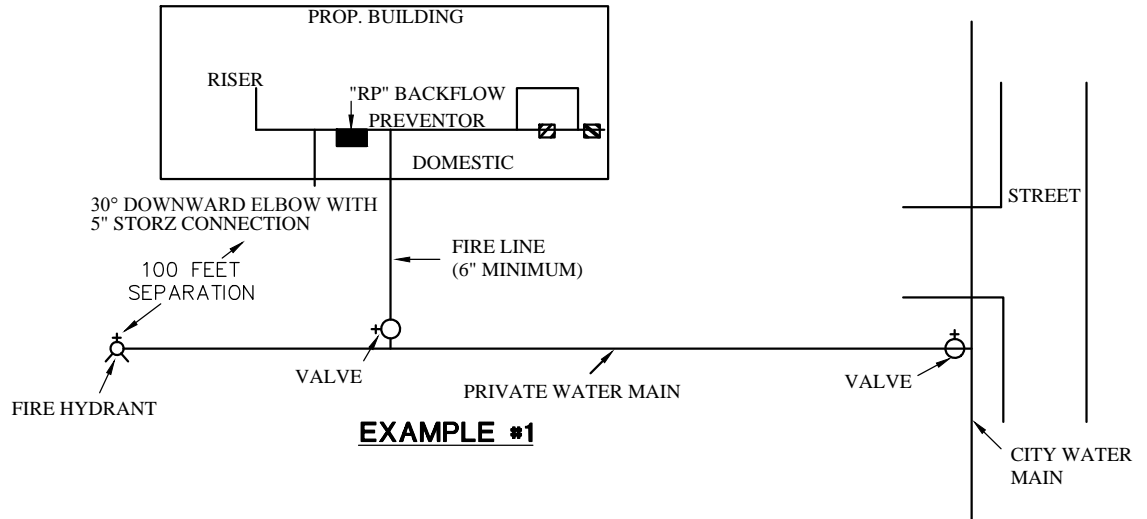

EXAMPLE #1

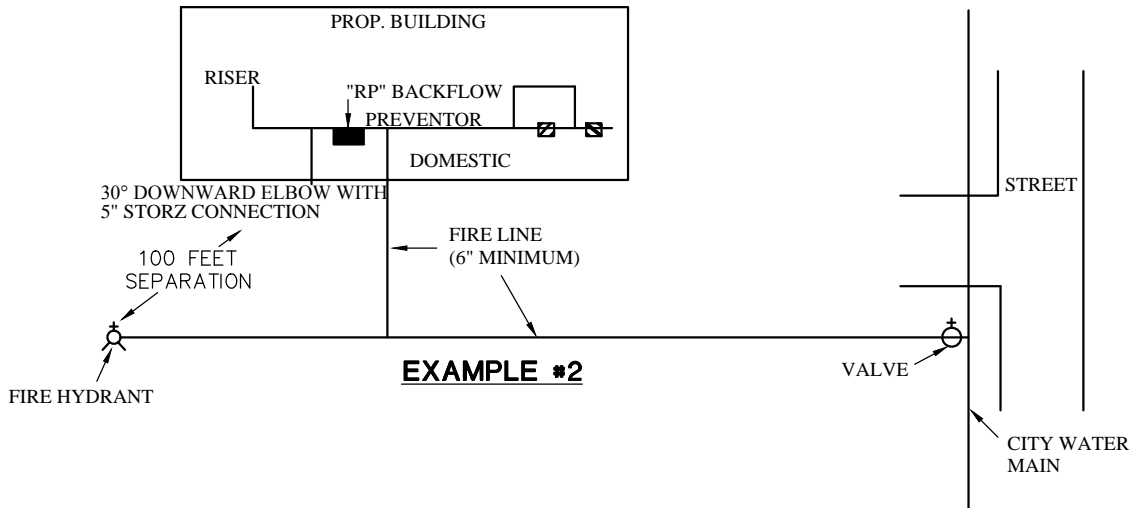

EXAMPLE #2

TESTING PROCEDURES FOR EXAMPLE #2

- A.** ENTIRE WATER LINE SHALL BE CONSIDERED THE FIRE LINE PER THE DEFINITIONS.
- B.** THE ENTIRE FIRE LINE SHALL BE INSTALLED, INSPECTED AND CERTIFIED BY A STATE LICENSED FIRE LINE INSTALLER.
- C.** CITY SHALL PERFORM BACTERIA TEST AFTER PRESSURE TEST AND DISINFECTION HAVE BEEN PERFORMED AND APPROVED.

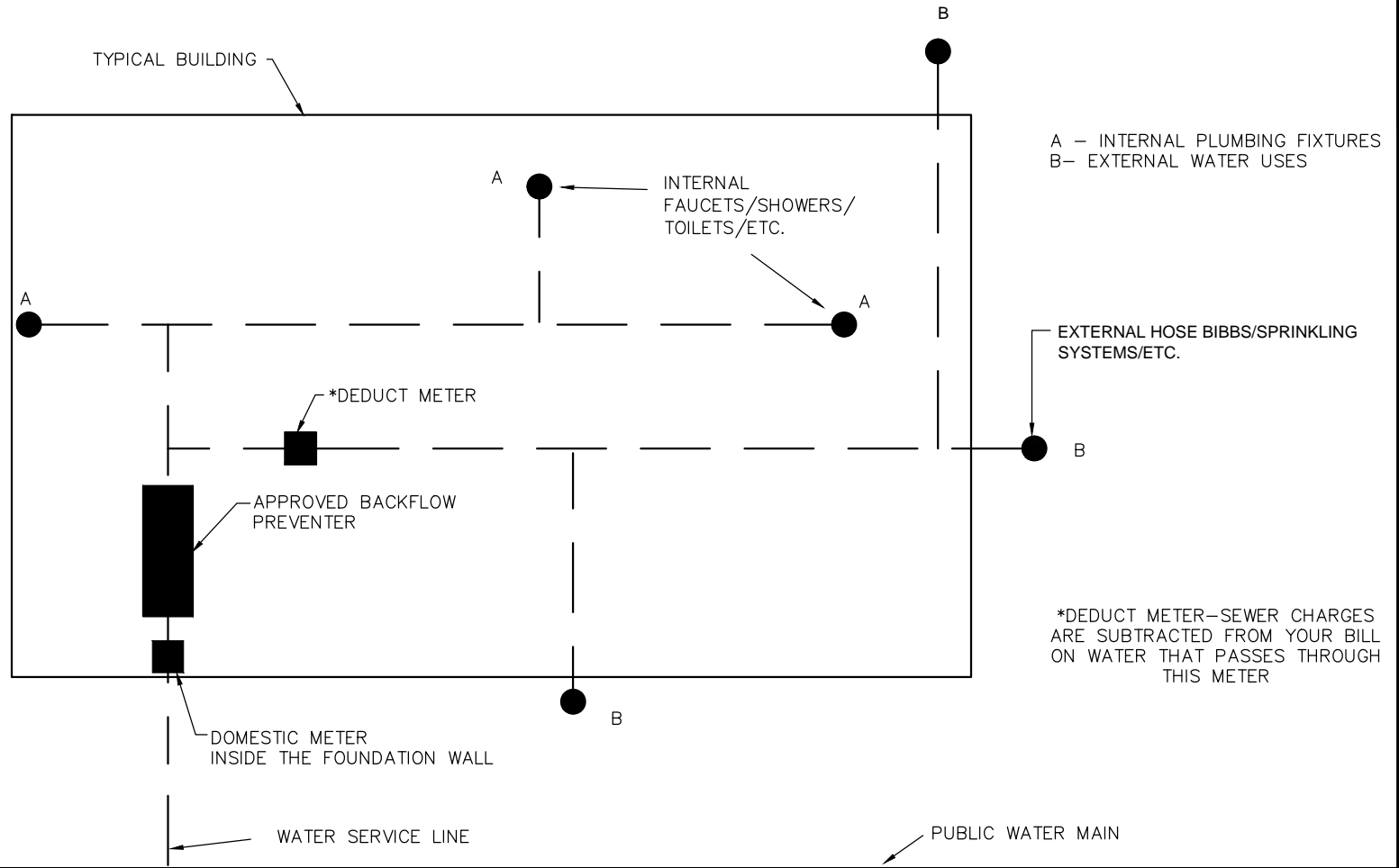

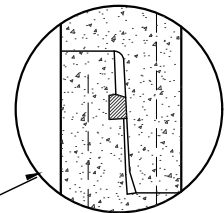
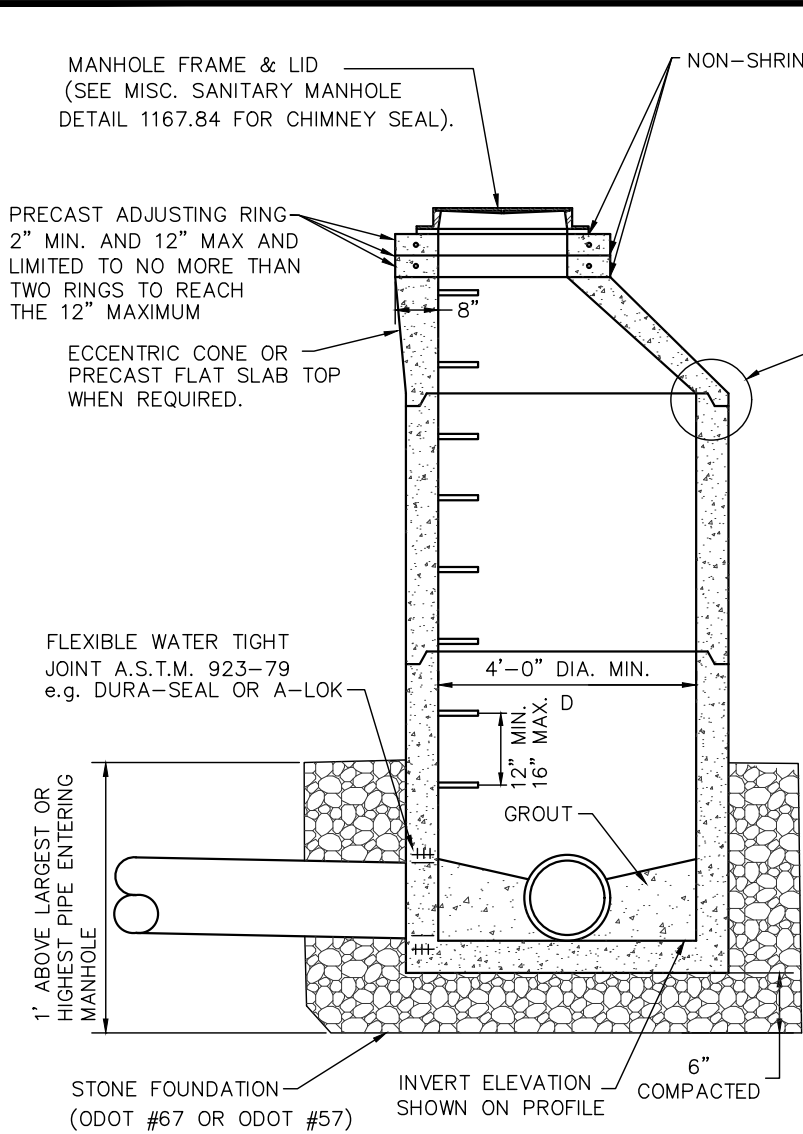

O-RING JOINT DETAIL
(MEETING ASTM SPEC. 443)

JOINTS MUST BE KEPT TO A MINIMUM.

NOTES

- A.** SANITARY MANHOLE FRAMES AND COVERS SHALL BE EQUAL TO NEENAH NO. R-1767 OR EAST JORDAN IRON WORKS NO. 1600. LID SHALL BE SANITARY LETTERED SOLID NON-VENTED, SELF-SEALING AND NON-BOLTED LIDS. NO LATERALS SHALL PROTRUDE INTO THE INTERIOR MANHOLE.
- B.** TO CONNECT INTO EXISTING MANHOLE, THE MANHOLE SHALL BE CORED AND AN A-LOK XP SERIES FLEXIBLE CONNECTOR OR EQUIVALENT SHALL BE INSTALLED PER MANUFACTURER'S RECOMMENDATIONS. NON-SHRINK GROUT ALTERNATIVE MAY BE USED IN SPECIAL CIRCUMSTANCES WHEN PREVIOUSLY APPROVED BY CITY.
- C.** MATERIALS FOR BASES, RISERS, AND OTHER PRECAST SECTIONS, INCLUDING REINFORCEMENTS SHALL COMPLY WITH ASTM C-478.
- D.** MAXIMUM SANITARY MANHOLE SPACING SHALL BE 350' FOR LESS THAN 15", 400' FOR 15" AND GREATER.
- E.** LOCATE THE CENTERLINE OF MANHOLE COVERS OVER THE CENTERLINE OF THE MAIN SEWER WHENEVER POSSIBLE.
- F.** CUT PIPE SHALL NOT EXTEND BEYOND THE INSIDE FACE OF THE MANHOLE WALL.
- G.** CONCRETE PLACED INSIDE THE MANHOLE SHALL NOT BE PLACED BETWEEN THE PIPE AND THE OPENING SO AS TO INTERFERE IN ANY WAY WITH THE FLEXIBILITY OF THE JOINT.
- H.** (4) 3/4" DIA. STAINLESS STEEL ANCHOR BOLTS AND NUTS TO FASTEN MANHOLE FRAME TO MANHOLE CONE OR FLAT LID SECTION WHEN REQUIRED BY THE CITY ENGINEER.

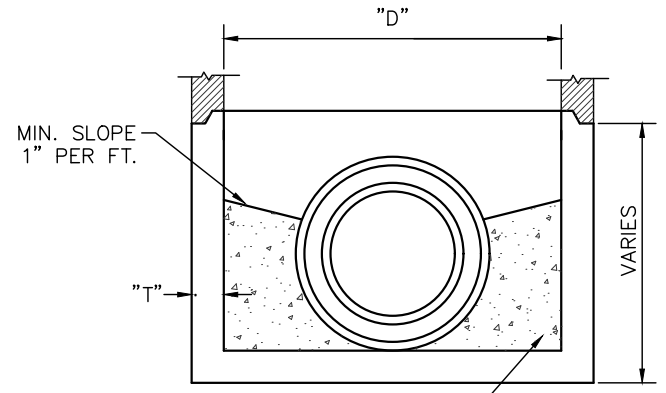

PRECAST BASE SECTION

PIPE SIZE	T	D
24" & UNDER	5"	48"
27" & ABOVE	6"	60"

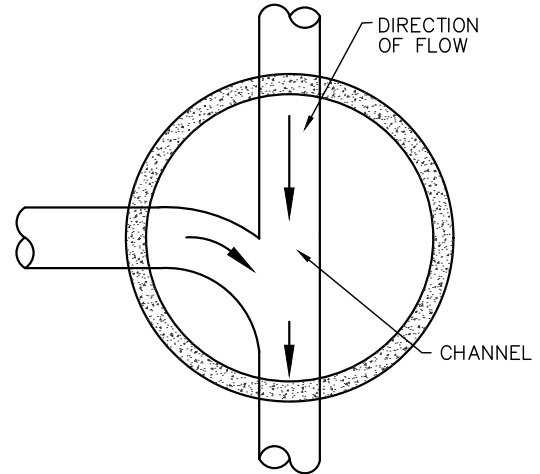

THE FLOW CHANNEL THROUGH MANHOLES SHALL BE MADE TO CONFORM IN SHAPE, SLOPE AND SMOOTHNESS TO THAT OF THE SEWERS.

STANDARD INVERT CHANNEL

ALL INVERTS TO BE CHanneled FOR OPTIMUM FLOW.

MANHOLE FRAME & LID
(SEE MISC. SANITARY MANHOLE
DETAIL 1167.84 FOR CHIMNEY SEAL).

MANHOLE FRAME & LID
NON-SHRINK GROUT

PRECAST ADJUSTING RING
2" MIN. AND 12" MAX. AND
LIMITED TO NO MORE THAN
TWO RINGS TO REACH THE
12" MAXIMUM

8"
24" MIN.

CONE SHALL BE ECCENTRIC
STANDARD TEE

'A'	'B'
8", 10", & 12"	8"
15" & 18"	10"
21" & 24"	12"

DROP CONNECTION MANHOLE

RUBBER O-RING GASKETS

BASE SECTION ONLY
SEE STANDARD DRAWING 900-1
FOR BASE SECTION DETAIL

1' ABOVE LARGEST OR HIGHEST
PIPE ENTERING MH UNLESS
OTHERWISE AUTHORIZED

B

6" MIN.

CONCRETE ENCASEMENT

WHEN DROPS ARE PRECAST
6" MIN. MAY BE OMITTED

4'-0"

"B"

PVC PIPE

STANDARD 90°
SHORT ELBOW

GROUT

1' ABOVE LARGEST OR
HIGHEST PIPE ENTERING
MANHOLE UNLESS
OTHERWISE AUTHORIZED

PRECAST BASE SECTION

APPROXIMATELY 1'-0"

CONCRETE ODOT
CLASS "QC-1"

NOTES

A. LOCATE THE CENTERLINE OF MANHOLE CONES OVER THE CENTERLINE OF THE MAIN SEWER WHENEVER POSSIBLE.

B. TYPE D MANHOLE SHALL BE USED WHERE THE DIFFERENCE IN INVERT ELEVATIONS IS GREATER THAN 2'-0".

C. ALL NOTES AND ASTM REFERENCES ON THE TYPE 3 SANITARY MANHOLE SHALL APPLY ON THE TYPE D SANITARY DROP MANHOLE.

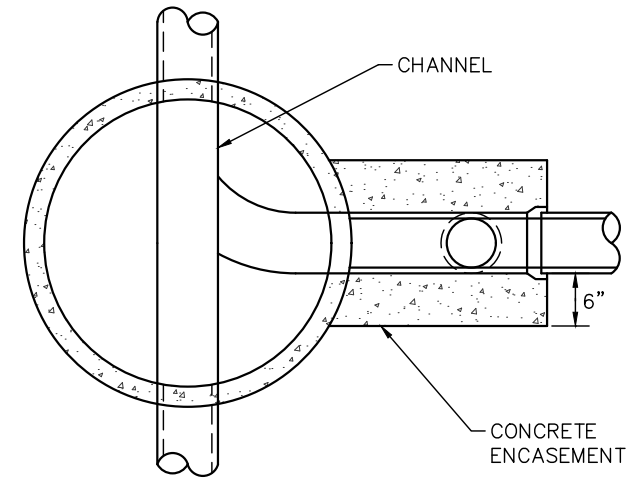

SECTION B-B

**CITY OF
URBANA**

TYPE D SANITARY DROP MANHOLE

REVISIONS:
04-10-19

DATE
APPROVED:
01-13-06

PAGE No.

1167.82

MANHOLE FRAME & LID
(SEE MISC. SANITARY MANHOLE
DETAIL 1167.84 FOR CHIMNEY SEAL).

PRECAST ADJUSTING RING
2" MIN. AND 12" MAX. AND
LIMITED TO NO MORE THAN
TWO RINGS

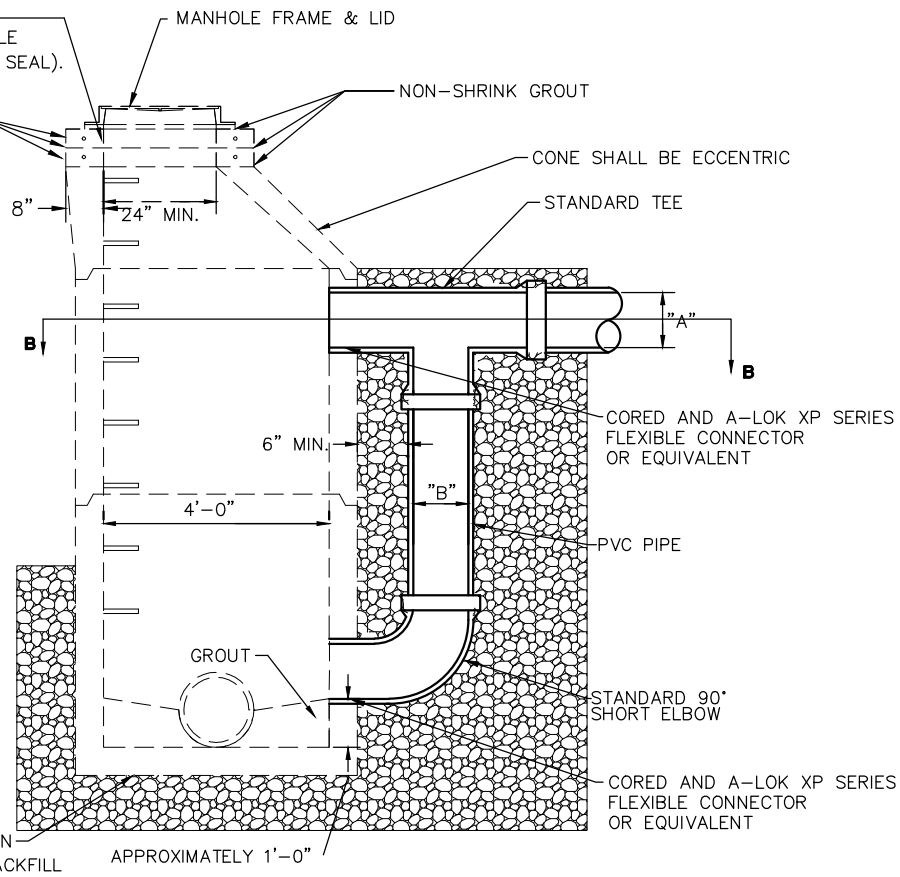

TYPE 1

NOTES

- A.** SANITARY DROP MANHOLE SHALL BE USED WHERE THE DIFFERENCE IN INVERT ELEVATIONS IS GREATER THAN 2'-0".
- B.** ALL NOTES AND ASTM REFERENCES ON THE TYPE 3 SANITARY MANHOLE SHALL APPLY ON THE SANITARY DROP ON EXISTING MANHOLE.
- C.** ALL NOTES AND ASTM REFERENCES ON THE TYPE D SANITARY DROP MANHOLE SHALL APPLY ON THE SANITARY DROP ON EXISTING MANHOLE.
- D.** THE DUCTILE IRON PIPE SHALL BE ANCHORED TO THE OUTSIDE OF THE EXISTING MANHOLE.

"A"	"B"
8", 10", & 12"	8"
15" & 18"	10"
21" & 24"	12"

DROP CONNECTION MANHOLE

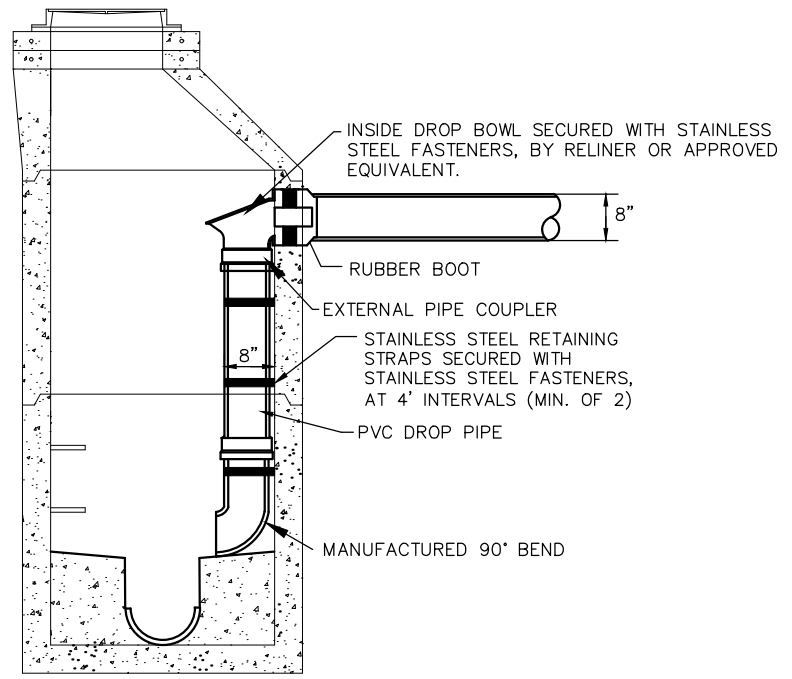

TYPE 2

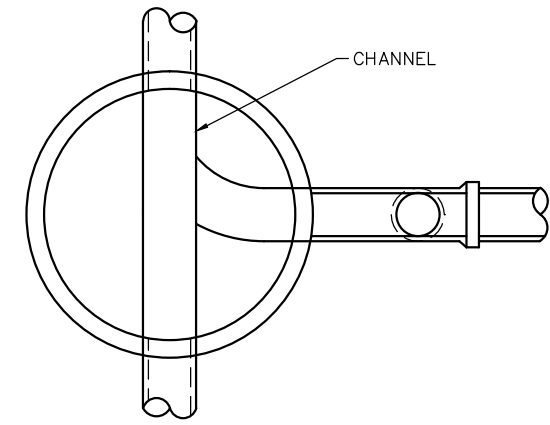

SECTION B-B

**CITY OF
URBANA**

**OUTSIDE SANITARY DROP ON EXISTING MANHOLE TYPE 1
INSIDE SANITARY DROP ON EXISTING MANHOLE TYPE 2**

REVISIONS: 12-20-12	DATE APPROVED: 01-13-06
PAGE No. 1167.83	

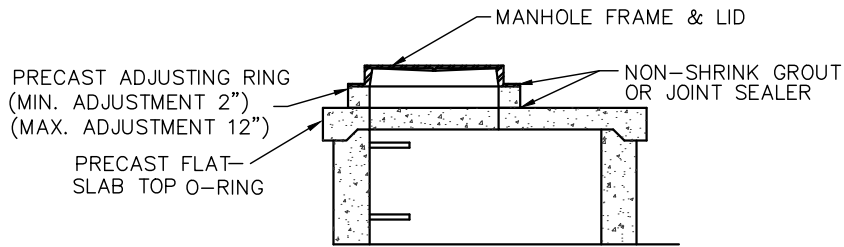

FLAT TOP SLAB

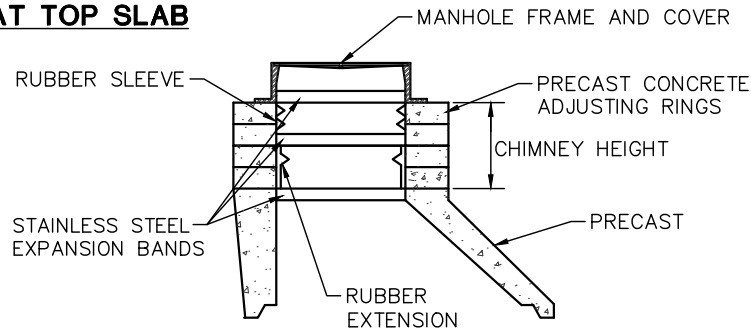

INTERNAL MANHOLE CHIMNEY SEAL

(REQUIRED BY ALL SANITARY APPLICATIONS)

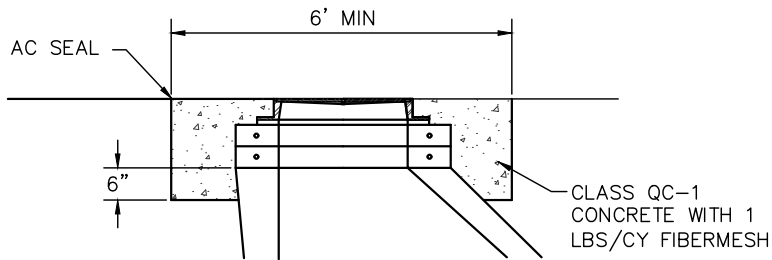

MANHOLE REPAIR CASTING CONSTRUCTION

NOTES:

1. PRECAST CONCRETE ADJUSTING RINGS- ENCASE WITH CONCRETE 6" DOWN FROM BARRELL TOP AND UP TO FLUSH WITH SURFACE. METAL ADJUSTING RINGS WILL NOT BE ALLOWED.
2. SET MANHOLE, PRECAST CONCRETE ADJUSTING RINGS AND CASTING AND PAVE OVER MANHOLE. THEN DIG OUT, ENCASE COLLARS AND CASTING AS PER DETAIL WITH CONCRETE TO THE SURFACE.

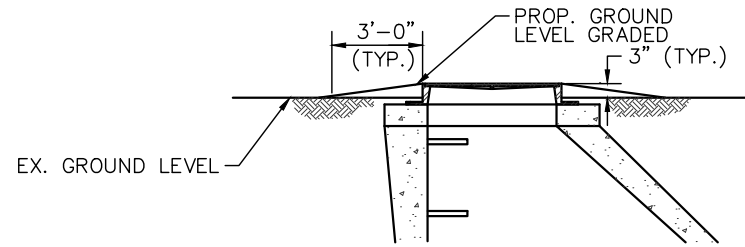

TYPICAL OFF STREET MANHOLE GRADING

NOTES

- A. MANHOLE STEPS SHALL BE SECURLY INSTALLED INTO EACH MANHOLE SECTION, BY THE MANUFACTURER, PRIOR TO DELIVERY TO THE JOB SITE.
- B. MANHOLE STEPS SHALL BE PFS-1 STEP BY M.A. INDUSTRIES OR EQUIVLENT.

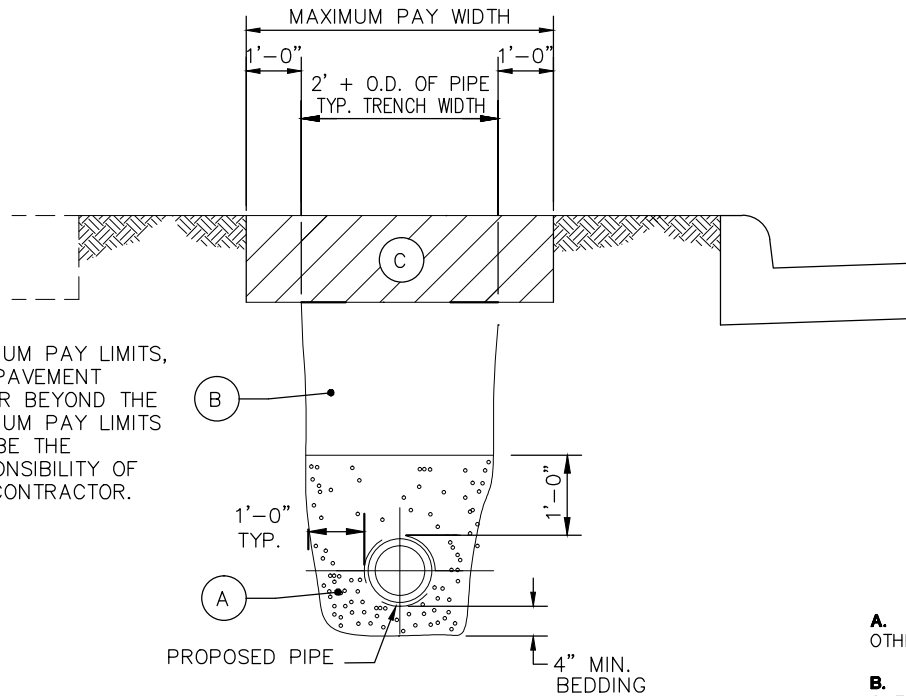

NOTE:
 MAXIMUM PAY LIMITS,
 ANY PAVEMENT
 REPAIR BEYOND THE
 MAXIMUM PAY LIMITS
 WILL BE THE
 RESPONSIBILITY OF
 THE CONTRACTOR.

SANITARY SEWER TRENCH DETAIL

SHOWN AS "OFF ROAD" APPLICATION

TRENCH DETAIL NOTES

A. STRUCTURAL BEDDING SHALL BE WASHED GRAVEL, ODOT 703 #8, #57, OR #67, OR OTHER APPROVED EQUIVALENT.

B. ALL TRENCHES WITHIN 5' OF PROPOSED OR EXISTING PAVEMENT, WALK, CURB AND GUTTER, DRIVES, ALLEYS, STONE AREAS, OR OTHER HARD SURFACE SHALL BE BACKFILLED WITH ODOT 703 WASHED GRAVEL TO WITHIN 12" OF SURFACE (#8, #57, OR #67).

ALL TRENCHES BEYOND 5' OCCURRING IN SEED AREAS ARE TO BE BACKFILLED WITH NATIVE FILL TO WITHIN 6" OF SURFACE. NATIVE FILL IS TO BE COMPACTED TO 98% OF ASTM D698 STANDARD PROCTOR CURVE.

C. OFF-PAVEMENT AREAS SHALL BE PROVIDED WITH A MINIMUM OF 6" OF TOPSOIL OVER THE COMPACTED MATERIAL AND THEN SEEDED AND MULCHED PER ODOT ITEM 659.

STREET AREAS SHALL FOLLOW TYPICAL SECTION 1167.20. GRAVEL DRIVE AREAS SHALL BE 12" OF 304 STABILIZED CRUSHED AGGREGATE. ASPHALT DRIVES SHALL BE REPAIRED WITH A MINIMUM OF 4" OF 448 SURFACE ASPHALT ON 8" OF 304 STABILIZED CRUSHED AGGREGATE. CONCRETE DRIVE AREAS SHALL BE 6" OF 452 PLAIN CONCRETE ON 6" OF 304 STABILIZED CRUSHED AGGREGATE.

D. THE OPEN ENDS OF ALL PIPES SHALL BE PLUGGED TO THE APPROVAL OF THE CITY BEFORE LEAVING THE WORK FOR THE NIGHT.

E. COMPACTED 304 IS TO BE USED UNDER CURB AND GUTTER AND SIDEWALKS WHERE DISTURBED BY CONSTRUCTION.

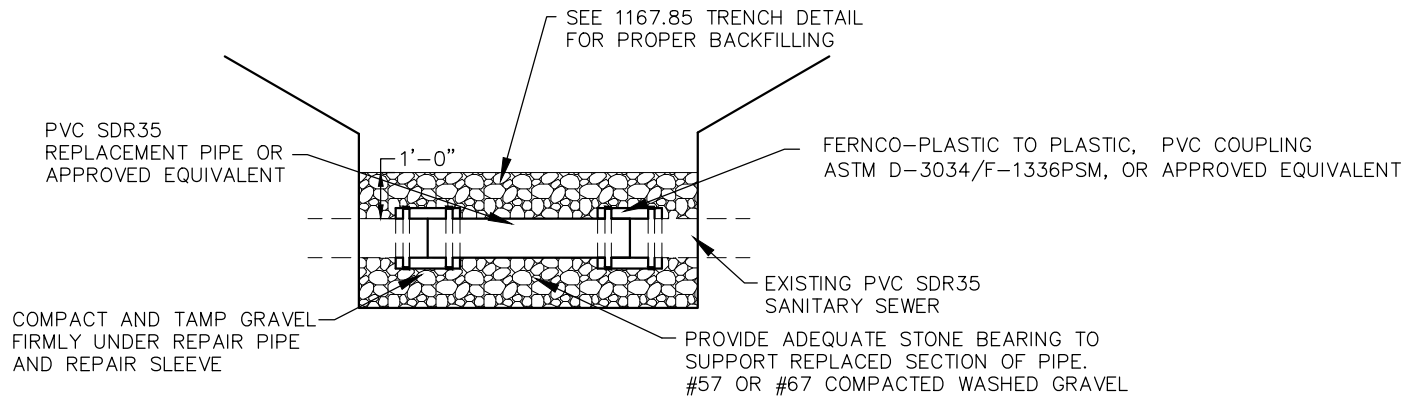

REPAIR OF EXISTING PVC SDR35 SANITARY SEWER

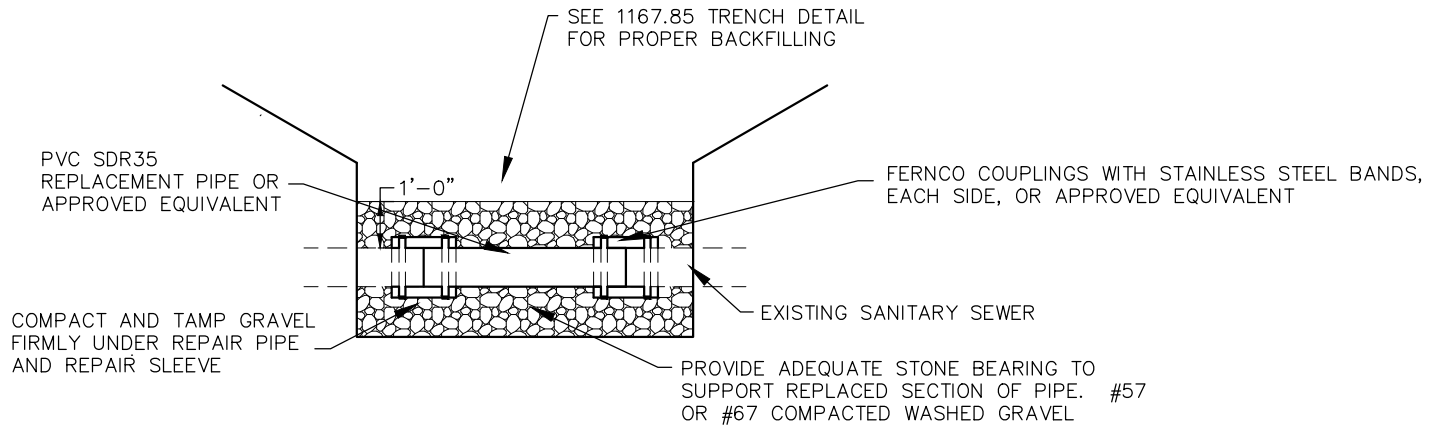

REPAIR OF EXISTING SANITARY SEWER OTHER THAN PVC

NOTES

- A.** RISER PIPE TO BE BEDDED SOLIDLY AGAINST UNDISTURBED GROUND. ALSO, TEE MAY BE SUBSTITUTED FOR WYE BRANCH IF SPECIFIED.
- B.** RISER PIPE TO BE INSTALLED SO THAT CONNECTING SERVICE SHALL HAVE A MINIMUM DEPTH OF 7' AT THE PROPERTY LINE UNLESS OTHERWISE DIRECTED BY THE CITY.
- C.** CONCRETE ENCASEMENT AND BLOCKING REQUIRED IF DEPTH OF CONNECTION IS 12' OR GREATER.
- D.** EACH SANITARY LATERAL MUST BE IN SEPARATE TRENCHES.

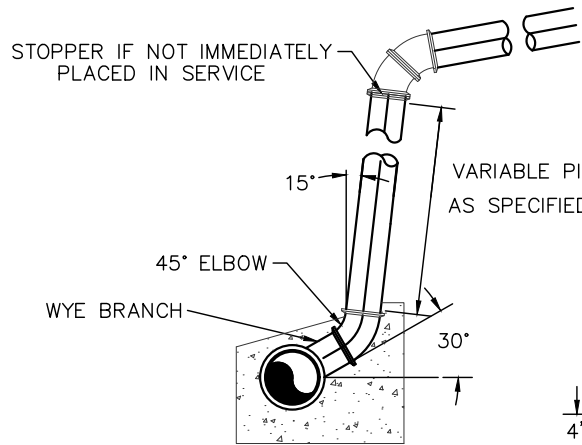
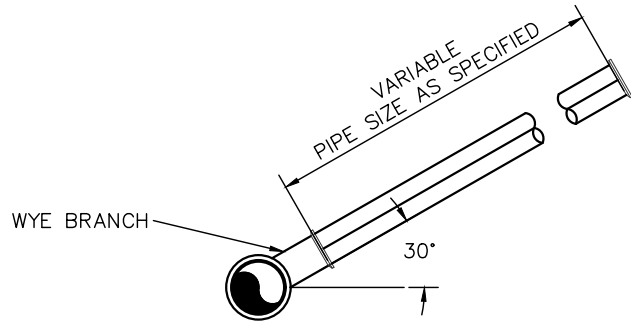

CONCRETE ENCASEMENT AND BLOCKING ODOT CLASS "QC-1".

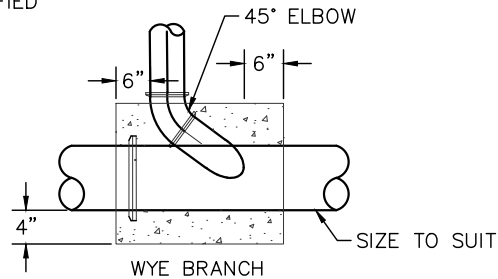

SERVICE RISER

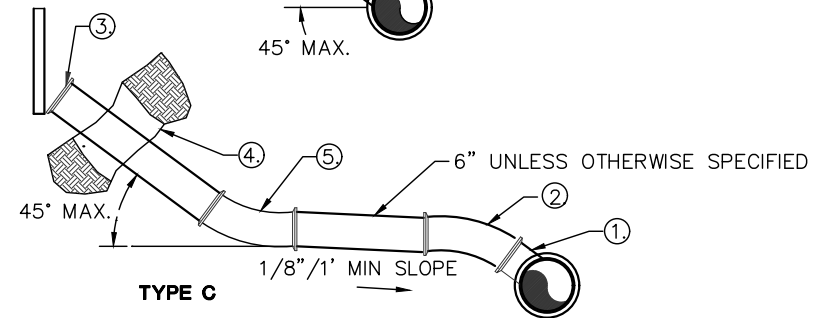
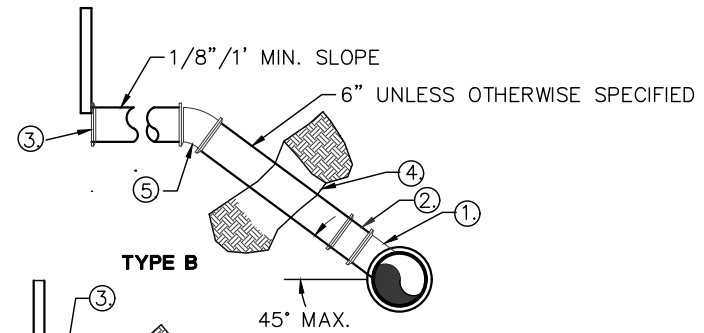
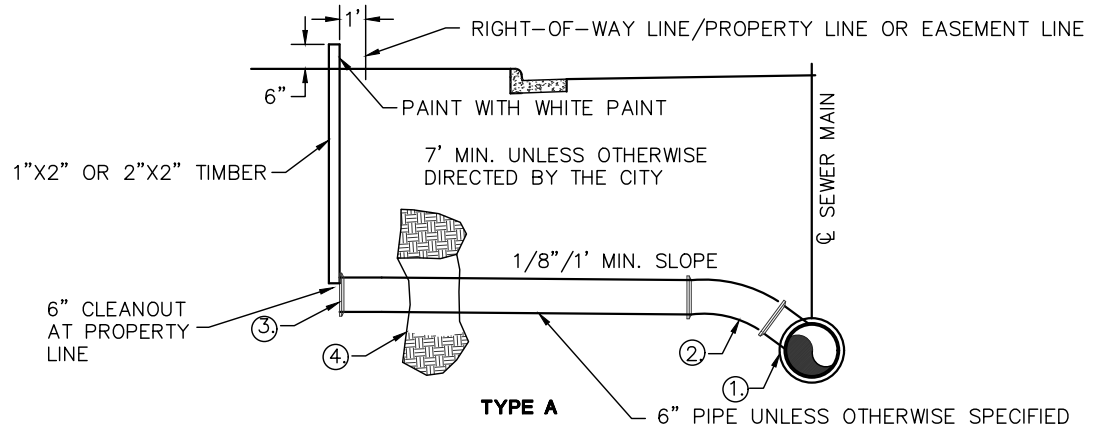

- ① 6" WYE—ROTATE 45° FROM HORIZONTAL UNLESS OTHERWISE SPECIFIED.
- ② 6" 1/8° BEND OR 1/16° BEND AS NEEDED.
- ③ CAP UNLESS JOINING EXISTING SERVICE LATERAL.
- ④ BED PIPE WITH 8" GRANULAR MATERIAL AND BACKFILL WITH GRANULAR MATERIAL TO 8" ABOVE PIPE. #57 OR #67 WASHED GRAVEL.
- ⑤ EXACT MEASUREMENTS MUST BE PROVIDED SHOWING DISTANCE FROM NEAREST MANHOLE, LENGTH OF LATERAL, BENDS, AND THE END OF LATERAL ELEVATION RELATIVE TO THE BACK OF CURB ELEVATION OR SOME OTHER REFERENCE POINT EASILY RECOVERED.

SERVICE LATERAL

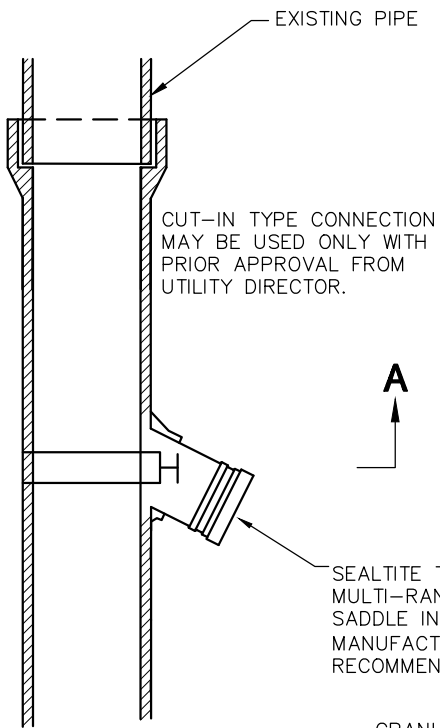

CUT-IN TYPE CONNECTION MAY BE USED ONLY WITH PRIOR APPROVAL FROM UTILITY DIRECTOR.

SEALTITE TYPE "E" MULTI-RANGE WYE SEWER SADDLE INSTALLED AS PER MANUFACTURER'S RECOMMENDATION

HOLE SHALL BE CAREFULLY CORED AND BE SAME DIAMETER AS OUTSIDE DIAMETER OF LATERAL CONNECTOR.

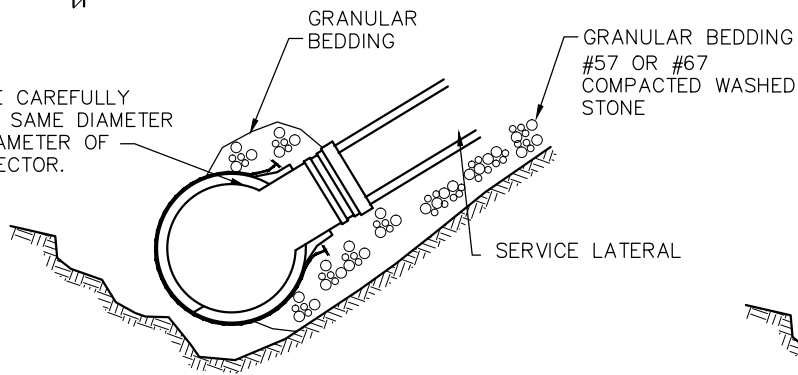

SECTION A-A

NOTES

- A.** A TEE MAY BE CUT IN OR SADDLE PLACED ONLY IF AN EXISTING LATERAL IS NOT PROVIDED.
- B.** ALL SADDLES AND CUTTING IN TEES MUST BE INSPECTED PRIOR TO COVERING, AND THE HOLE IN THE EXISTING PIPE SHALL BE INSPECTED AND APPROVED PRIOR TO INSTALLATION.
- C.** OTHER SADDLE TYPES THAT MAY BE APPROVED ON CASE-BY-CASE BASIS BY THE UTILITY DIRECTOR.
- D.** ON LOW FLOW AND PVC PIPE SDR 35 USE CUT IN TEE.

COUPLING (FOR CONNECTIONS DETAIL SEE REPAIR OF EXISTING SANITARY SEWER PIPE DETAIL 1167.86).

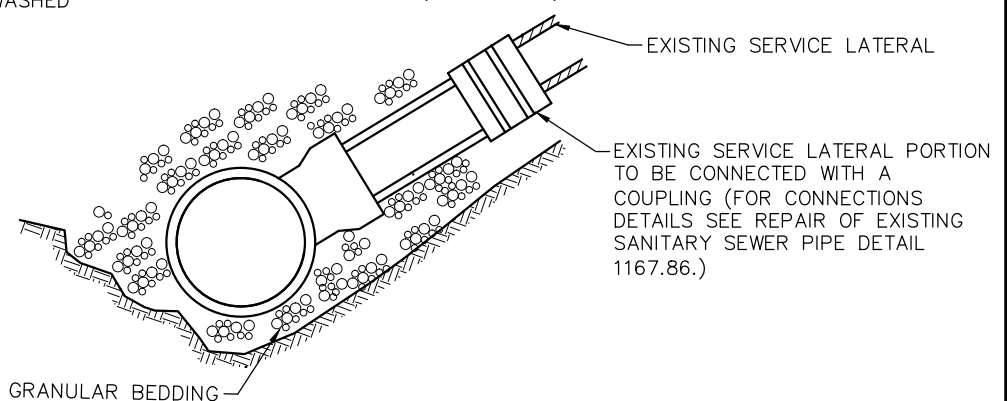
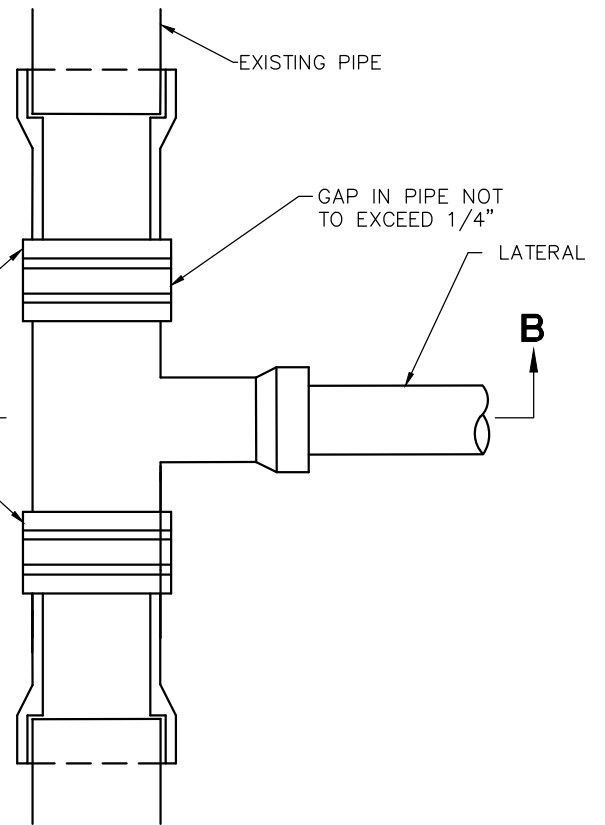

SECTION B-B

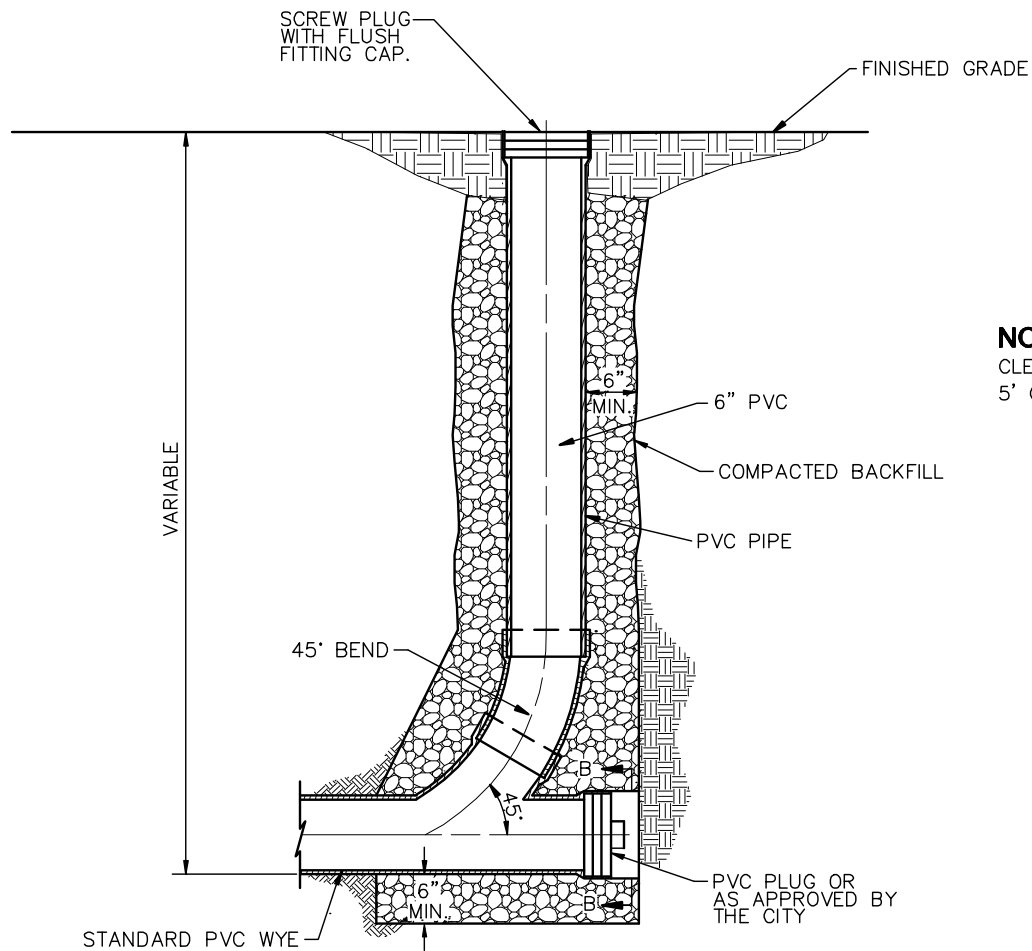

NOTE

CLEANOUT TO BE LOCATED WITHIN 5' OF OUTSIDE OF BUILDING WALL.

CLEANOUT DETAIL
AT SANITARY LATERALS ONLY

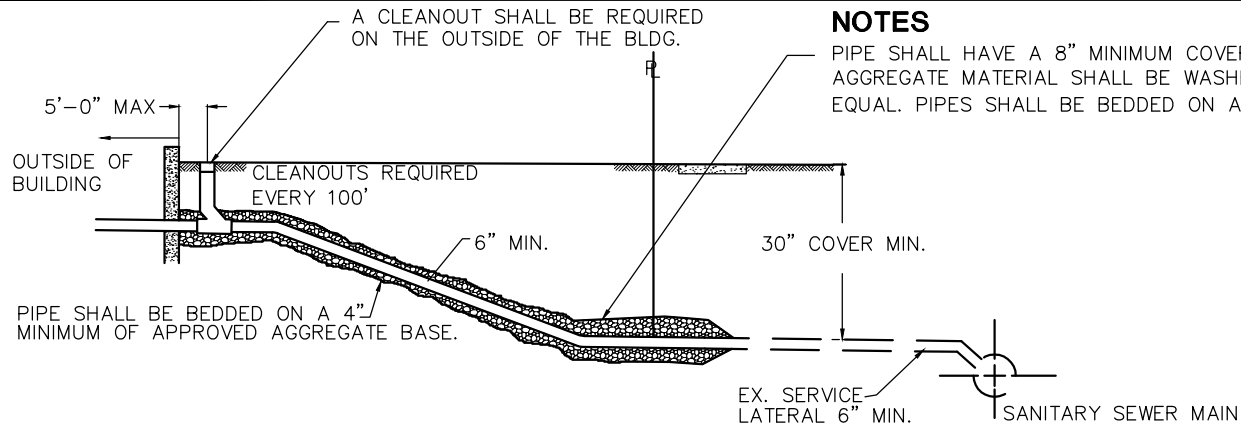

NOTES

PIPE SHALL HAVE A 8" MINIMUM COVER OF APPROVED AGGREGATE MATERIAL. APPROVED AGGREGATE MATERIAL SHALL BE WASHED STONE #8, #57 OR #67 OR OTHER APPROVED EQUAL. PIPES SHALL BE BEDDED ON A 4" MINIMUM OF APPROVED AGGREGATE BASE.

NOTES

- A.** SEPTIC TANKS, WHEN ABANDONED, SHALL BE DEWATERED BY AN ACCEPTED SEPTAGE HAULER AND PROPERLY FILLED WITH GRANULAR MATERIAL. DRAIN HOLES SHALL BE BROKEN OUT ON THE BOTTOM AND SIDES OF THE TANK WHEN DIRECTED BY THE CITY.
- B.** ROOF DOWNSPOUTS, EXTERIOR FOUNDATION DRAINS, SUMP PUMPS OR OTHER SURFACE RUNOFF OR GROUNDWATER SHALL NOT BE CONNECTED TO THE SANITARY SEWER MAIN.
- C.** ANY INDIVIDUAL OR FIRM INSTALLING SEWER CONNECTIONS SHALL BE APPROVED BY THE CITY.
- D.** BEFORE BEGINNING WORK, A SEWER TAP PERMIT MUST BE OBTAINED FROM UTILITY BILLING OFFICE AND APPLICABLE FEES MUST BE PAID.
- E.** WHEN THE BUILDING CONNECTION MUST ENTER INTO A PAVED PORTION OF THE STREET OR ALLEY, A STREET OPENING PERMIT MUST BE OBTAINED FROM THE CITY ENGINEERING DEPARTMENT BEFORE BEGINNING WORK.
- F.** WATER SERVICES SHALL BE A MINIMUM OF 10' MEASURED HORIZONTALLY FROM THE SEWER SERVICE AND SHALL BE A MINIMUM OF 18" ABOVE THE CROWN (WHENEVER POSSIBLE) OF THE SANITARY SEWER MAIN WHERE THE WATER SERVICE CROSSES THE SEWER MAIN.

PIPE

- A.** THE PIPE MATERIAL SHALL BE PVC SDR 35 OR, SCHEDULE 40, UTILIZING PURPLE PRIMER, OR AN APPROVED EQUIVALENT.
- B.** PIPE SIZES FOR BUILDING CONNECTIONS SHALL BE 6" MINIMUM FOR ALL USES. THE LATERALS SHALL BE RUN TO WITHIN 3' OF THE OUTSIDE OF THE BUILDING.

INSPECTION

- A.** A TAP INSPECTION SHALL BE REQUIRED ON ALL NEW BUILDING CONNECTIONS AND ALSO ON THE REPLACEMENT OF EXISTING BUILDING CONNECTIONS.
- B.** WHEN THE BUILDING SEWER IS READY FOR INSPECTION, THE CITY SHALL BE GIVEN 24 HOURS ADVANCE NOTICE. THE PIPE SHALL BE LEFT UNCOVERED UNTIL AN INSPECTION HAS BEEN MADE AND APPROVED.
- C.** ANY NEW BUILDING CONNECTION INSTALLED WITHOUT AN INSPECTION SHALL RESULT IN NO ISSUANCE OF A WATER METER FOR THE BUILDING. IF THIS OCCURS, THE ENTIRE LATERAL SHALL BE UNCOVERED SO THAT A PROPER INSPECTION CAN BE MADE.
- D.** NO TAP FEE IS REQUIRED IF AN OLD BUILDING SEWER IS TO BE REUSED. AN INSPECTION WILL BE REQUIRED. THE SANITARY DEPT. SHALL INSPECT THE ENTIRE BUILDING CONNECTION FROM THE CLEANOUT TO THE PROPERTY LINE CONNECTION OR TO THE MAIN SEWER, WHICHEVER IS APPLICABLE.
- E.** WHEN A SADDLE IS TO BE INSTALLED, THE INSPECTOR SHALL BE PRESENT WHILE THE SANITARY SEWER MAIN IS BEING CUT INTO. A SADDLE MAY BE USED WHERE A TEE OR WYE IS NOT PRESENT FOR LATERAL CONNECTION.

MISC.

- A.** STREET EXCAVATION REQUIRES A STREET OPENING PERMIT.
- B.** FOUNDATION DRAINS ARE TO BE CONNECTED TO THE STORM SEWER.

PIPE LAYING

- A.** THE OPEN ENDS OF ALL PIPES SHALL BE PLUGGED OR OTHERWISE CLOSED WITH A WATERTIGHT PLUG TO THE APPROVAL OF THE CITY BEFORE LEAVING THE WORK SITE FOR THE NIGHT.
- B.** THE JOINING OF PIPE WITH CONCRETE SHALL NOT BE ACCEPTED.
- C.** BEFORE MAKING A CONNECTION TO AN EXISTING SEWER OR SERVICE LATERAL, THE CONTRACTOR SHALL CHECK THE EXISTING PIPE BY UTILIZING A DYE TEST TO SEE THAT THE EXISTING PIPE IS CONNECTED TO THE SANITARY SEWER MAIN.
- D.** IN THE CASE WHERE A 90° CORNER IS REQUIRED IN THE BUILDING CONNECTION LINE, TWO 45° BENDS SHALL BE USED IN LIEU OF A 90° BEND.
- E.** THE BUILDING CONNECTION LINE SHALL BE LAID IN AS STRAIGHT A LINE, FROM THE BUILDING TO THE EXISTING LATERAL, AS POSSIBLE.
- F.** ALL NEW CONSTRUCTION SHALL HAVE SANITARY LATERALS INSTALLED.
- G.** MINIMUM SLOPE OF SANITARY LATERAL SHALL BE 1% GRADE (1/8" PER FOOT) MAXIMUM SLOPE (SEE 1167.87).

**CITY OF
URBANA**

BUILDING CONNECTION DETAIL

REVISIONS:
07-02-09
12-20-12

DATE
APPROVED:
01-13-06

PAGE No.
1167.90

LOW PRESSURE AIR TEST

A. AFTER BACKFILLING, THE AIR TEST SHALL BE CONDUCTED BETWEEN TWO CONSECUTIVE MANHOLES. ALL PIPE OUTLETS MUST BE PLUGGED IN THE SECTION BEING TESTED WITH SUITABLE TEST PLUGS. ONE OF THE PLUGS USED AT A MANHOLE MUST BE TAPPED AND EQUIPPED FOR AN AIR INLET CONNECTION FOR FILLING THE LINE FROM THE AIR COMPRESSOR. AIR SHALL BE SUPPLIED SLOWLY TO THE TEST SECTION UNTIL THE INTERNAL PRESSURE REACHES APPROXIMATELY 4 PSI. IF THE PIPE IS BELOW EXISTING GROUNDWATER LEVEL, THE INTERNAL PRESSURE SHALL BE INCREASED BY THE AVERAGE BACK PRESSURE OF ANY GROUNDWATER THAT MAY BE OVER THE PIPE, BUT IN NO CASE SHOULD THE INTERNAL PRESSURE EVER EXCEED 5 PSI.

B. AT LEAST 2 MINUTES SHALL BE ALLOWED FOR THE AIR PRESSURE TO STABILIZE. WHEN THE PRESSURE HAS STABILIZED AND IS AT OR ABOVE 3.5 PSI, THE AIR SUPPLY SHALL BE DISCONNECTED AND TIMING SHALL BEGIN WITH A STOP WATCH. THE STOP WATCH SHALL BE ALLOWED TO RUN UNTIL THE PRESSURE HAS DROPPED 1.0 PSI. IF THE TIME SHOWN ON THE STOP WATCH IS GREATER THAN THE SPECIFIED MINIMUM TIME, THE SECTION SHALL BE CONSIDERED TO HAVE PASSED THE TEST. TIME MAY BE INTERPOLATED FROM THE FIGURES LISTED BELOW.

DEFLECTION TEST

A. DEFLECTION TESTS SHALL BE PERFORMED BY THE CONTRACTOR ON ALL FLEXIBLE PIPE. THE TEST SHALL BE CONDUCTED AFTER THE FINAL BACKFILL HAS BEEN IN PLACE AT LEAST 30 DAYS TO PERMIT STABILIZATION OF THE SOIL-PIPE SYSTEM.

B. NO PIPE SHALL EXCEED A DEFLECTION OF 5%. IF DEFLECTION EXCEEDS 5%, REPLACEMENT OR CORRECTION SHALL BE ACCOMPLISHED IN ACCORDANCE WITH THE REQUIREMENTS OF APPROVING AGENCY.

C. THE RIGID BALL OR MANDREL USED FOR THE DEFLECTION TEST SHALL HAVE A DIAMETER NOT LESS THAN 95% OF THE BASE INSIDE DIAMETER OR AVERAGE INSIDE DIAMETER OF THE PIPE DEPENDING ON WHICH IS MANUFACTURED. THE PIPE SHALL BE MEASURED IN COMPLIANCE WITH ASTM D-2122 STANDARD TEST METHOD OF DETERMINING DIMENSIONS OF THERMOPLASTIC PIPE AND FITTINGS. THE TEST SHALL BE PERFORMED WITHOUT MECHANICAL PULLING DEVICES.

MANHOLE VACUUM TEST

ALL SANITARY SEWER MANHOLES SHALL BE VACUUM TESTED BY THE CONTRACTOR USING THE FOLLOWING PROCEDURES FROM ASTM C-1244.

A. PREPARATION OF THE MANHOLE

1. ALL LIFT HOLES SHALL BE PLUGGED.
2. ALL PIPES ENTERING THE MANHOLE SHALL BE TEMPORARILY PLUGGED TAKING CARE TO SECURELY BRACE THE PIPES AND PLUGS TO PREVENT THEM FROM BEING DRAWN INTO THE MANHOLE.

B. PROCEDURE

1. THE FIRST HEAD SHALL BE PLACED AT THE TOP OF THE MANHOLE IN THE CASTING IN ACCORDANCE WITH THE MANUFACTURER'S RECOMMENDATIONS.
2. A VACUUM OF 10" OF MERCURY (4.9 PSI) SHALL BE DRAWN ON THE MANHOLE, THE VALVE ON THE VACUUM LINE OF THE TEST HEAD CLOSED, AND THE VACUUM PUMP SHUT OFF. THE TIME SHALL BE MEASURED FOR THE VACUUM TO DROP TO 9" OF MERCURY (4.4 PSI).
3. THE MANHOLE SHALL PASS IF THE TIME FOR THE VACUUM READING TO DROP FROM 10" OF MERCURY (4.9 PSI) TO 9" OF MERCURY (4.4 PSI) MEETS OR EXCEEDS THE VALUES INDICATED ON THE TABLE.

4. IF THE MANHOLE FAILS THE INITIAL TEST, NECESSARY REPAIRS SHALL BE MADE BY AN APPROVED METHOD. THE MANHOLE SHALL THEN BE RETESTED UNTIL A SATISFACTORY TEST IS OBTAINED.

PIPE DIA. (IN.)	Time for Longer Length (sec)	Specified Minimum for Length (L) Shown (min:sec)						
		100 FT.	150 FT.	200 FT.	250 FT.	300 FT.	350 FT.	400 FT.
6	0.854L	5:40	5:40	5:40	5:40	5:40	5:40	5:42
8	1.520L	7:34	7:34	7:34	7:34	7:36	8:52	10:08
10	2.374L	9:26	9:26	9:26	9:53	11:52	13:51	15:49
12	3.418L	11:20	11:20	11:24	14:15	17:05	19:56	22:47
15	5.342L	14:10	14:10	17:48	22:15	26:42	31:09	35:36
18	7.692L	17:00	19:13	25:38	32:03	38:27	44:52	51:16
21	10.470L	19:50	26:10	34:54	43:37	52:21	61:00	69:48
24	13.674L	22:47	34:11	45:34	56:58	68:22	79:46	91:10

SPECIFICATION TIME FOR LENGTH (L) SHOWN (MIN-SEC)

*ALL TESTS SHALL BE WITNESSED BY A CITY OF URBANA ENGINEERING DEPARTMENT REPRESENTATIVE.

DIAMETER, INCHES

DEPTH (FT.)	48 60 72		
	TIME, SECONDS		
8 OR LESS	20	26	33
10	25	33	41
12	30	39	49
14	35	46	57
16	40	52	67
18	45	59	73
20	50	65	81
22	55	72	89
24	59	78	97
26	64	85	105
28	69	91	113
30	74	98	121

MINIMUM TEST TIMES FOR VARIOUS MANHOLE DIAMETERS

CITY OF URBANA

SANITARY SEWER TESTING NOTES

REVISIONS:
09-10-09
12-20-12

DATE APPROVED:
01-13-06

PAGE No.
1167.91

NOTES

- A.** NO WORK SHALL BE APPROVED OR ACCEPTED BY THE CITY UNLESS 2 WORKING DAYS NOTICE OF COMMENCING WORK IS GIVEN TO THE CITY.
- B.** ALL TEMPORARY PAVEMENT AND SIDEWALK SHALL BE MAINTAINED BY THE CONTRACTOR OR DEVELOPER AT HIS OWN EXPENSE IN A SUITABLE AND SAFE CONDITION FOR TRAFFIC UNTIL PERMANENT REPLACEMENT IS MADE OR THE PROJECT IS FINALLY ACCEPTED BY THE CITY.
- C.** ROOF DRAINS, FOUNDATION DRAINS, SUMP PUMPS, AND ALL OTHER CLEAR WATER CONNECTIONS TO THE SANITARY SEWER SYSTEM ARE PROHIBITED.
- D.** WHEN A SEWER IS TO BE EXTENDED AT THE DOWNSTREAM MANHOLE OR FIRST MANHOLE IN THE NEW LINE, IT SHALL BE PLUGGED BEFORE CONSTRUCTION BEGINS. IF THE SEWER IS SMALLER OR EQUAL TO 12" DIAMETER, IT SHALL BE PLUGGED BY PLACING A POLY-ETHYLENE BAG APPROXIMATELY 6" INTO THE SEWER PIPE. SIZES LARGER THAN 12" WILL BE PLUGGED BY OTHER APPROVED METHODS. NO PLUGS SHALL BE REMOVED UNTIL CONSTRUCTION IS COMPLETED AND SOIL IS STABILIZED AND THEN ONLY AS DIRECTED BY THE CITY.
- E.** CONSTRUCTION OF SANITARY SEWERS SHALL INCLUDE THE CITY DYE TESTING AS DETERMINED BY THE CITY OF ALL PIPES TO BE CONNECTED TO THE NEW SEWER PRIOR TO BACKFILLING.
- F.** WHEN A NEW CASTING OR OTHER PUBLIC PROPERTY IS ABANDONED IT REMAINS CITY PROPERTY, UNLESS OTHERWISE DIRECTED.
- G.** NEW SEWERS MUST HAVE EPA PLAN APPROVAL OR ANY SEWER THAT IS RELOCATED OR RESIZED.

EXCAVATION AND PIPE LAYING

- A.** THE LAYING OF THE PIPE SHALL COMMENCE AT THE LOWEST POINT, WITH THE BELL END LAID UPGRADE. THE PIPE SHALL BE CENTERED IN THE TRENCH AND ALL PIPE SHALL BE LAID WITH ENDS ABUTTING AND TRUE TO LINE AND GRADE.
- B.** LASER SHALL BE USED INSIDE THE PIPE WHENEVER POSSIBLE UNLESS OTHERWISE APPROVED.

UTILITY STAKING

- A.** LASER METHOD – OFFSET AND GRADE AT EACH MANHOLE. OFFSET AND GRADE 50' AND 100' OUT FROM EACH MANHOLE UNLESS OTHERWISE APPROVED.

TESTING - ALL PHASES PERFORMED BY CONTRACTOR OR DEVELOPER

- A.** BEFORE ANY SEWER LINE IS PLACED INTO SERVICE OR ACCEPTED BY THE CITY, IT SHALL BE SUBJECTED TO AND PASS LOW PRESSURE AIR TEST. EACH RUN BETWEEN MANHOLES, WITH ALL SERVICE LATERALS STUBBED INTO PROPERTY LINES, SHALL BE TESTED BEFORE BEING ACCEPTED. THE CONTRACTOR OR DEVELOPER SHALL FURNISH ALL EQUIPMENT AND MATERIAL NECESSARY TO CONDUCT THIS TEST. THE TRENCH SHALL BE COMPLETELY BACKFILLED BEFORE TESTING.

- B.** SEE SANITARY TESTING NOTES.

- C.** BEFORE FINAL ACCEPTANCE BY THE CITY AND BEFORE ANY SERVICE LINE IS PUT INTO USE, ALL SANITARY SEWERS AND MANHOLES SHALL BE THOROUGHLY CLEANED OF ALL FOREIGN MATTER BY USE OF A SEWER-JET OR EQUAL, TYPE OF EQUIPMENT BY THE CONTRACTOR. SEWER-JET PROCEDURE MUST BE PERFORMED BEFORE CONTRACTOR T.V. TESTS THE PIPE.

HOUSE CONNECTIONS

- A.** NO SERVICE LINE SHALL BE ALLOWED TO CONNECT DIRECTLY INTO A MANHOLE, SUBJECT TO APPROVAL BY THE CITY IN SPECIFIC CASES.
- B.** THE ENDS OF ALL SERVICE LINES OR TEES SHALL BE ACCURATELY LOCATED, MAPPED, AND GIVEN TO THE CITY WITHIN 15 DAYS AFTER INSTALLATION.
- C.** BEFORE MAKING A CONNECTION TO AN EXISTING SEWER TAP OR SEWER LATERAL, THE CONTRACTOR SHALL CHECK THE EXISTING PIPE BY UTILIZING A SEWER EEL, STRAP, OR SEWER ROD TO SEE THAT THE EXISTING PIPE IS CONNECTED TO THE MAIN SEWER. IF NEEDED, THE CONTRACTOR MAY NEED TO USE A HYDRAULIC SEWER CLEANER.
- D.** LATERALS FROM THE MAIN TO THE PROPERTY LINE SHALL BE 6" MINIMUM WITH CLEANOUT AT THE PROPERTY LINE.
- E.** A RIGHT-OF-WAY PERMIT TO OPEN, ALTER, OR DISTURB ANY PUBLIC SEWER MUST BE OBTAINED.
- F.** IN THE DEMOLISION OF EXISTING BUILDING, ALL ABANDONED SEWER LATERALS SHALL BE CAPPED AT THE OWNER'S EXPENSE.

PIPE

- A.** ALL MAINLINE PIPE AND SPECIALS SHALL BE PVC SDR-35 UNLESS OTHERWISE APPROVED BY THE CITY. MINIMUM DIAMETER OF PIPE SHALL BE 8".
- B.** DUCTILE IRON PIPE WILL BE USED IN STREAM CROSSINGS AND WHERE MAXIMUM SEPARATION CANNOT BE MAINTAINED OR WHEN DEPTH OF SEWER EXCEEDS 25 FEET.
- C.** ALL JOINTS SHALL BE OF THE BELL AND SPIGOT TYPE, THE BELLS BEING FORMED INTEGRALLY WITH THE PIPE. THE BELL SHALL CONTAIN A FACTORY INSTALLED ELASTOMETRIC GASKET WHICH IS POSITIVELY RETAINED. NO SOLVENT CEMENT JOINTS WILL BE PERMITTED IN FIELD CONSTRUCTION EXCEPT AS SPECIFICALLY AUTHORIZED BY THE CITY.

FLEXIBLE PIPES	MATERIAL SPECIFICATIONS	JOINT SPECIFICATIONS
POLYVINYL CHLORIDE	ASTM D-3034 (SDR-35) PIPE STIFFNESS = 46PSI	ELASTOMERIC GASKET ASTM D-3212
DUCTILE IRON	ANSI A-21.51 & AWWA C-151	ANSI A-21.11 & AWWA C-111

- 1.** SDR = OUTSIDE DIAMETER DIVIDED BY WALL THICKNESS.
- 2.** THE SPECIFICATIONS ABOVE SHALL BE THOSE MOST RECENTLY ADOPTED BY THE APPROPRIATE STANDARDS SETTING ORGANIZATIONS.

SANITARY SEWER PUMP STATION

REFER TO SANITARY SEWER DESIGN CRITERIA FOR ADDITIONAL CONSTRUCTION STANDARDS.

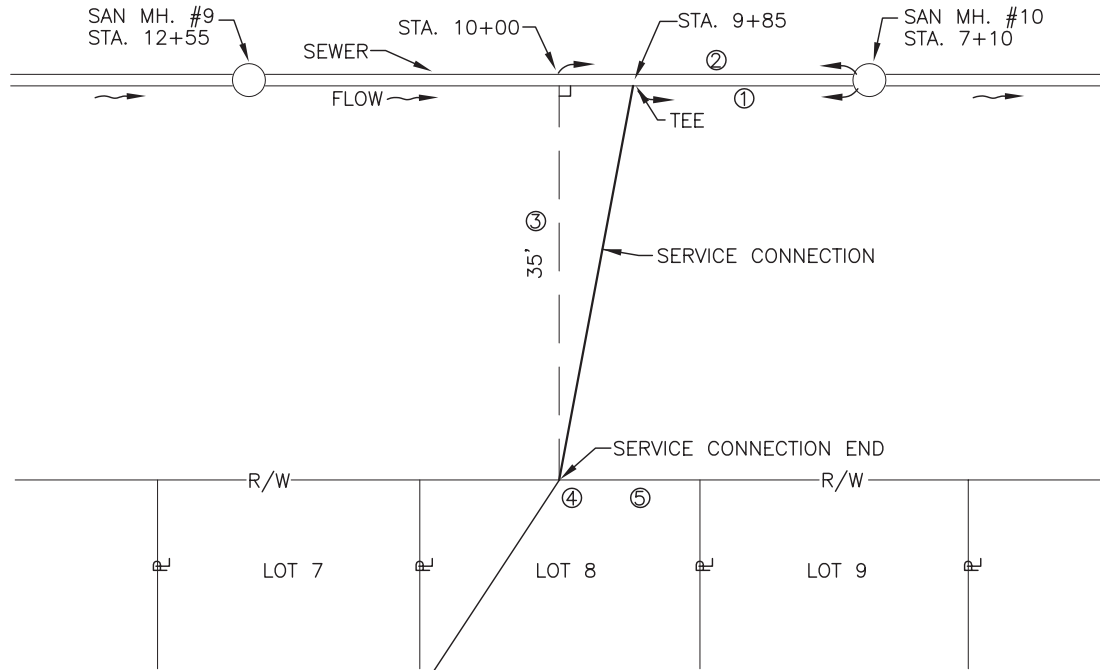

EXAMPLE

1. 275'
2. 290'
3. 35'
4. 8.9'
5. 942.9

THE CONTRACTOR SHALL SUPPLY THE FOLLOWING INFO TO THE SATISFACTION OF THE CITY

- ① HORIZONTAL DISTANCE OF TEE TO DOWNSTREAM MANHOLE.
- ② HORIZONTAL DISTANCE OF SERVICE CONNECTION END TO DOWNSTREAM MANHOLE ALONG SEWER.
- ③ PERPENDICULAR DISTANCE FROM SEWER TO SERVICE CONNECTION END.
- ④ DEPTH OF SERVICE CONNECTION END FLOW LINE TO ORIGINAL GROUND.
- ⑤ ELEVATION OF SERVICE CONNECTION END FLOW LINE.
- ⑥ ELEVATION OF BACK OF CURB OR SOME OTHER REFERENCE POINT ABOVE LATERAL.

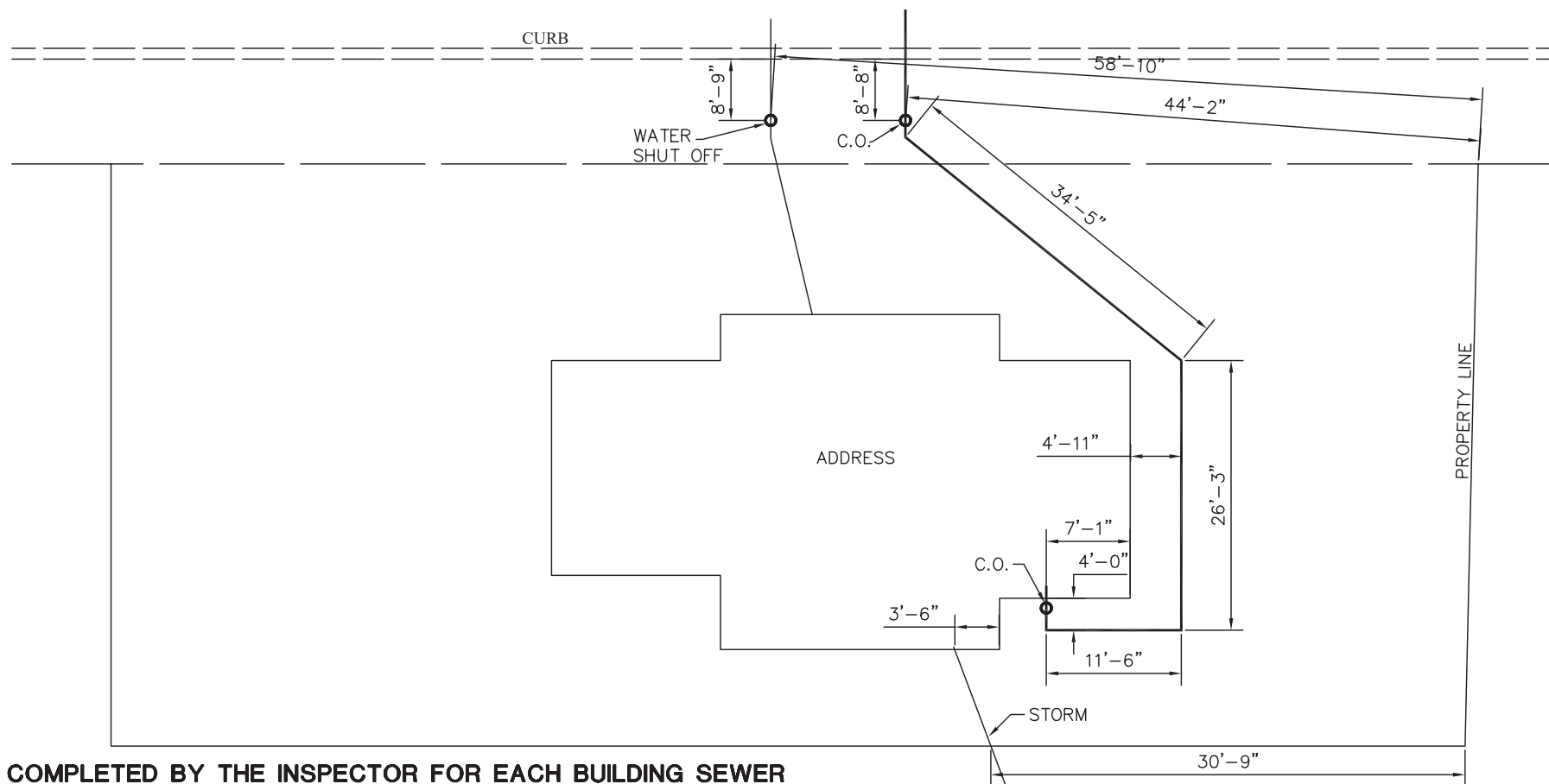

TO BE COMPLETED BY THE INSPECTOR FOR EACH BUILDING SEWER

SAMPLE SITE SKETCH. GIVE DIMENSIONS FOR ALL UNDERGROUND PIPES. MAKE A DIFFERENT SKETCH FOR EACH UTILITY, IF NEEDED. FOR EXAMPLE, IF THIS HOUSE HAD DOWN SPOUT LEADERS, A SEPARATE STORM SHEET WOULD BE NEEDED.

**CITY OF
URBANA**

**SERVICE CONNECTION LOCATION REFERENCE
(BUILDING IN PLACE)**

REVISIONS:

DATE
APPROVED:
01-13-06
PAGE No.

1167.94

NOTES:

- A. ALL FITTINGS TO BE RESTRAINED.
- B. CHIMNEY SEALS MUST BE INSTALLED.
- C. PRECAST MANHOLE RISER SECTION 5'-0" DIAMETER MIN. ASTM C478. NOTE ACTUAL SIZE TO BE DESIGNED WITH SIZE OF FORCEMAIN AND EACH INDIVIDUAL SITUATION.
- D. IN WET AREAS SEAL BOTTOM WITH POURED CONCRETE BASE OR PRECAST MANHOLE BASE.
- E. LOCATION OF THESE ARE AT THE DISCRETION OF THE CITY ENGINEER. (TYPICAL AROUND 650')

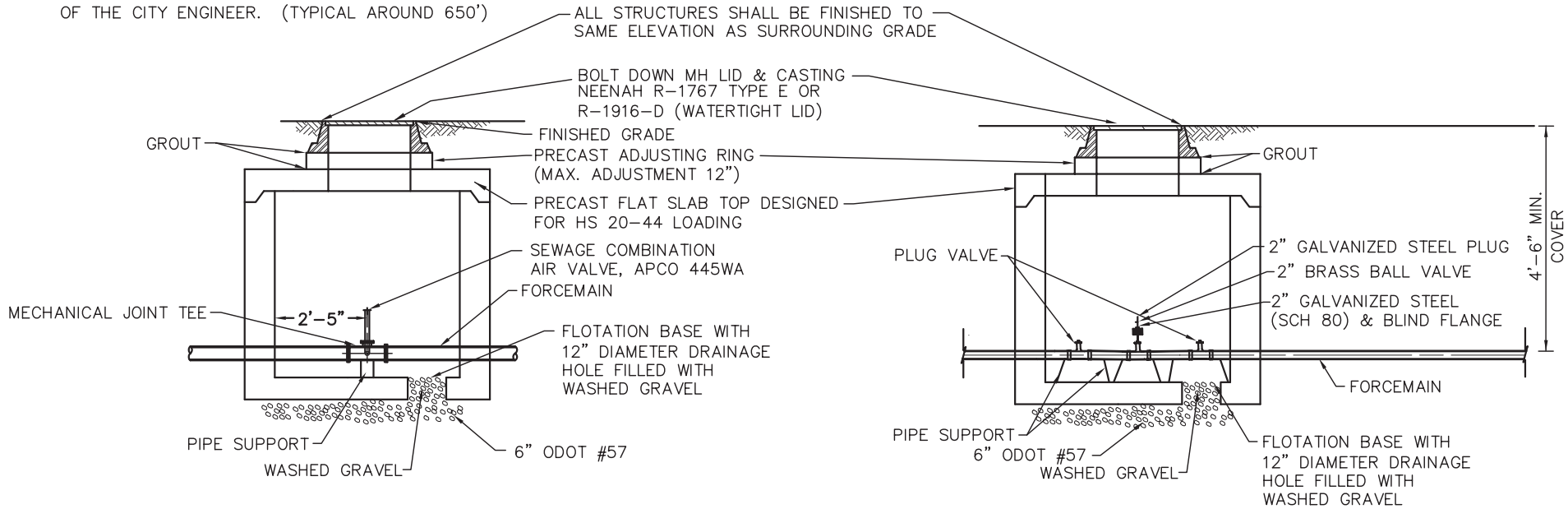

**SEWAGE COMBINATION
AIR VALVE IN MANHOLE**

**FORCE MAIN PRESSURE
CLEANOUT**